



Plankton, Aerosol, Cloud, ocean
Ecosystem (PACE)

Ocean Color Instrument (OCI)

**OVERVIEW OF NASA'S OCEAN
COLOR INSTRUMENT SOLAR
CALIBRATION ARCHITECTURE,
PRE-LAUNCH TESTS AND
PRELIMINARY ON-ORBIT RESULTS**

SPIE Sensors and Imaging 2024



JOSEPH KNUBLE

OCI Lead Instrument Systems Engineer

Principle Planetary Engineer

NASA GSFC Code 592





Agenda



- OCI Solar Calibration Driving Uncertainty Requirements
- Solar Calibration System Architecture
- Solar Calibration Orbital Maneuver
- Pre-Launch Tests
 - Diffuser BRDF
 - Course Radiometric
 - Stray Light
- Preliminary On-Orbit Results

(More details available in the SPIE conference paper. Joseph Knuble et al.)



OCI Radiance Calibration Equation



$$L_t = K_1 * K_2(t) * (1 - K_3(T - T_{ref})) * K_4(\theta) * K_5(dn) * K_p * dn$$

- L_t = Radiance, unit: $W / (m^2 \mu m sr)$
 - K_1 = absolute gain factor; unit: $(W / (m^2 \mu m sr)) / dn$ **Discussed Today**
 - $K_2(t)$ = relative gain factor as a function of time t ; unitless
 - K_3 = temperature correction $[(deg C)^{-1}]$ (vector)
 - T = Temperatures measured at relevant locations [deg C] (vector)
 - T_{ref} = Reference Temperature [deg C]
 - θ = scan angle [deg]
 - K_4 = (θ) response versus scan ; unitless
 - K_5 = nonlinearity factor ; unitless **Discussed Today**
 - dn = dark-corrected instrument counts
 - K_p = polarization correction
-
- K_1 of OCI is measured pre-launch at GSFC with GLAMR
 - K_1 drifts over mission life. The new K_1 is derived on-orbit from solar calibration.
 - K_1 is absolute, K_2 is relative to “ $T=0$ ” a.k.a first solar cal.
 - K_5 is also measured pre-launch with GLAMR but can change over mission life.
 - K_5 is trended on-orbit using solar calibration with *Progressive Time Delay Integration*
 - Charge is accumulated in the CCD serial register by skipping clock cycles then read-out. Simulates variable power optical source.



Driving Solar Calibration Uncertainty Requirements and Error Budgets



- K1 uncertainty requirement: Generally $\leq 1.6\%$ 1- σ below 900nm
 - *Contributions to K1 Uncertainty Discussed Today:*
 - Diffuser BRDF Characterization Uncertainty. Requirement: Generally $\leq 1.25\%$ 1- σ
 - On-Orbit Stray Light. Requirement: $\leq 0.3\%$ of solar diffuser radiance (L_{Bright})
 - *Contributions to K1 Uncertainty Not Discussed Today:*
 - Solar Target Geometry Uncertainty. – *Discussed in paper, not enough time for today's talk.*
 - Diffuser Polarization Effects
 - Response Vs. Scan Angle Residual Uncertainty at the Solar Cal Port Angle
 - Uncertainty in Solar Irradiance
 - Detector Noise
- K2 uncertainty requirement: $\leq 0.26\%$ 1- σ for 340nm to 865nm and $\leq 0.29\%$ for 940nm and above
 - *Contributions to relative uncertainty include pointing jitter, variation in solar irradiance, noise etc.*
- K5 uncertainty requirement: $\leq 0.3\%$ 1- σ for most bands, relaxed in some.
 - *Contributions to K5 uncertainty on-orbit include pointing jitter, target uniformity correction, noise, etc.*



OCI Instrument & Solar Cal Overview

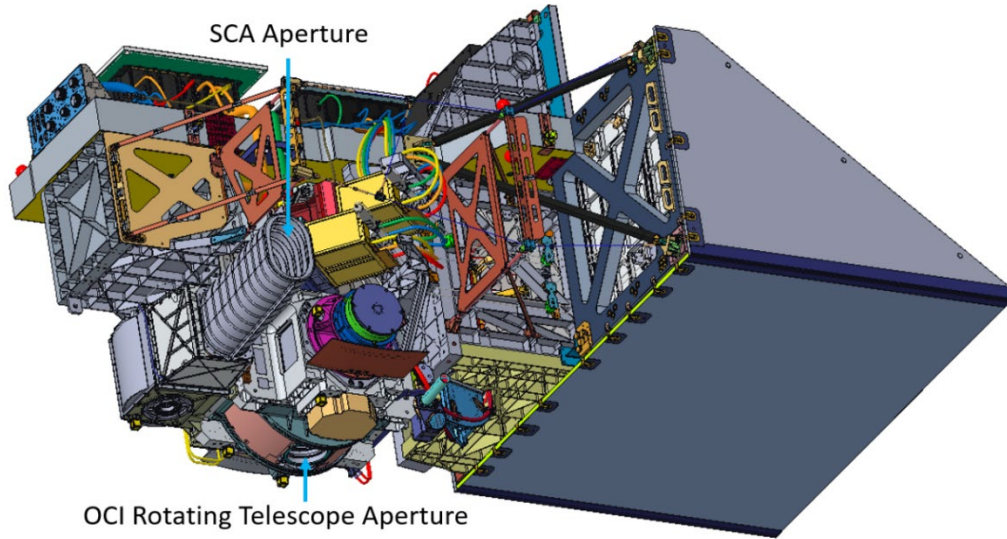

The Solar Calibration Assembly (SCA) consists of

- Three selectable targets on a stepper motor carousel
 - Two quartz QVDs: Daily and Monthly Bright Targets.
 - One Acktar Fractal Black Target: Monthly Dim Target
- Repeatability door driven by a cam
- Baffle

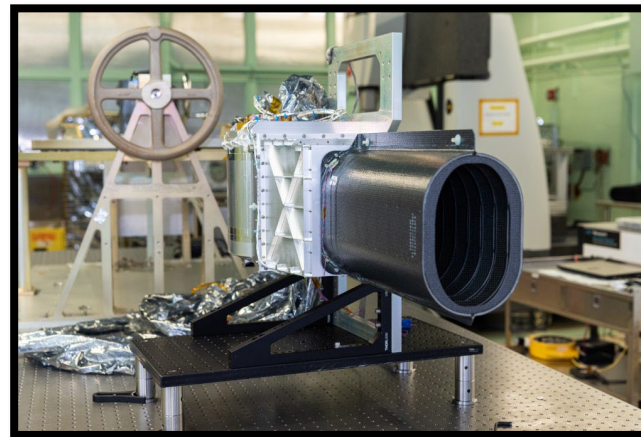
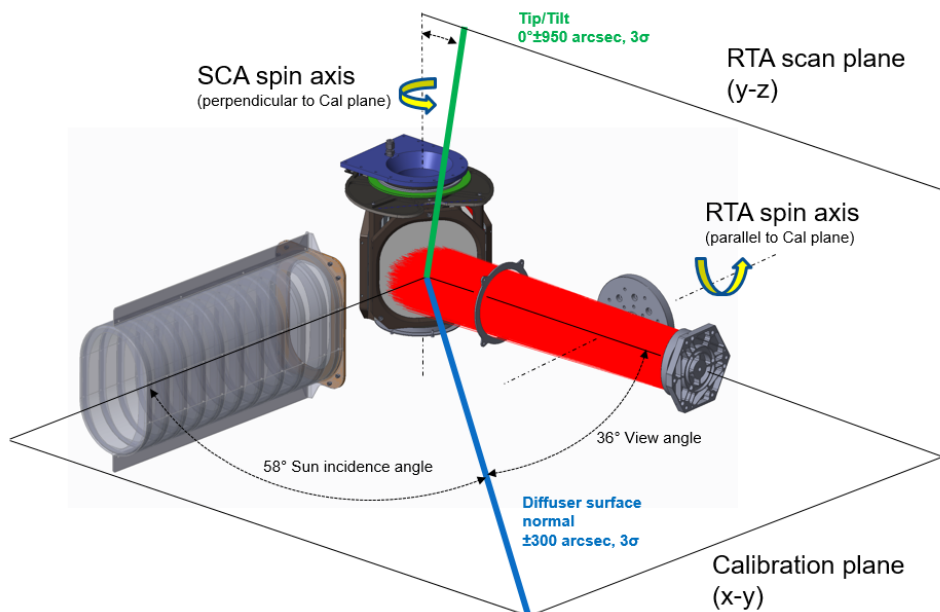

Flight SCA



Carousel with Three Targets



PACE / OCI Solar Calibration Maneuver

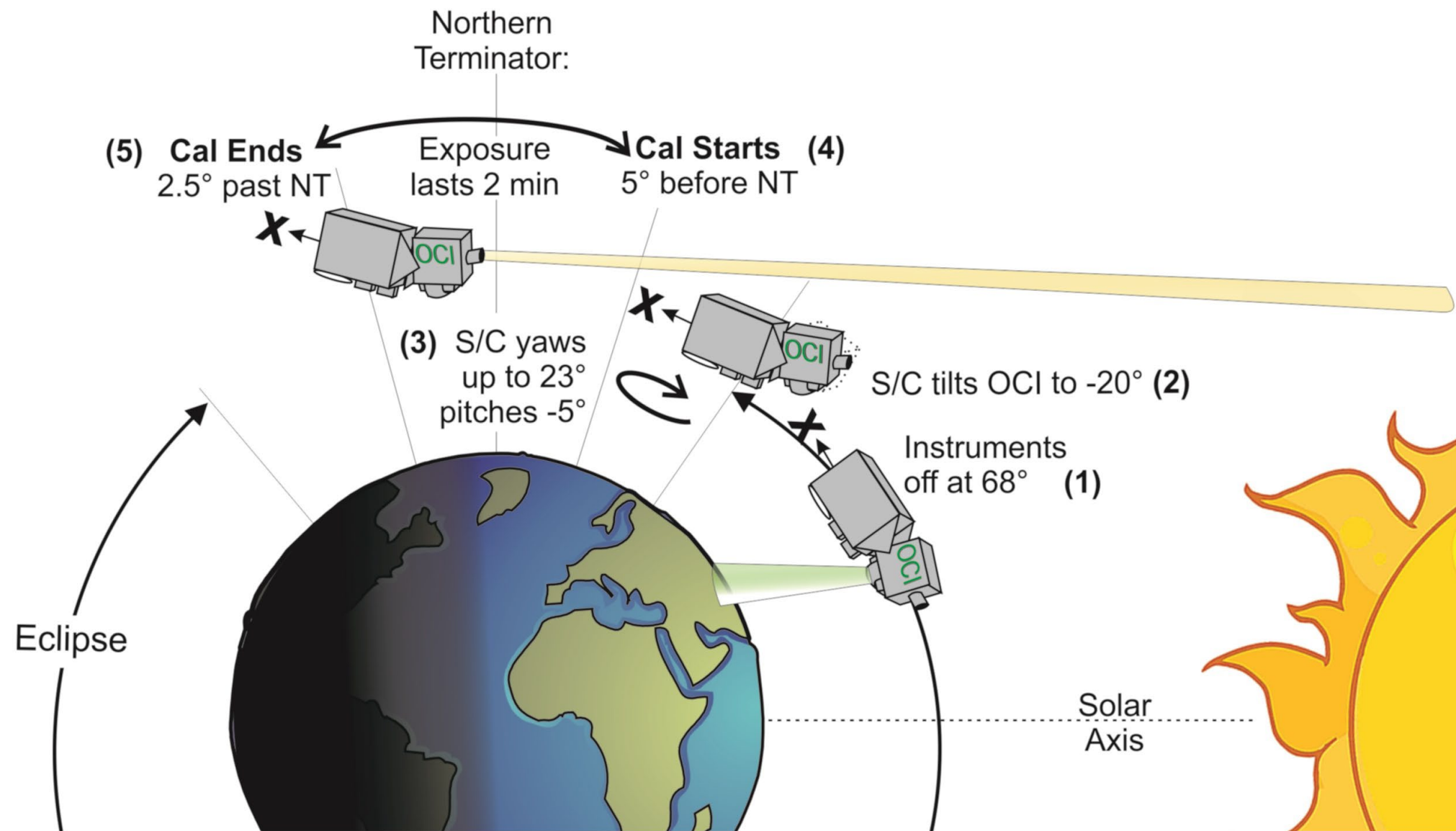



Where did the SCA design come from?



Design Trades Driven By Uncertainty Requirements and Other Constraints

| Design | Rationale |
|--|--|
| Use of Quartz QVDs | Spectralon could not meet K1 & K2 requirements in the UV due to degradation. |
| Use of Two Quartz QVDs | A single QVD target still could not meet K1 & K2 requirements due to target degradation. |
| Use of Dim Target with PTDI | Electronics linearity could change on orbit and K5 requirements could not be met. Target with PTDI trends non-linearity changes. |
| Use of Fractal Black for Dim Target | Reflectivity seemed to simulate Llow at certain bands.. (Unfortunately BRDF was more specular than expected.) |
| Target Sizes | Provides a uniform scene over a 5deg swath while staying in volume constraints. |
| Including a re-usable door | Not for contamination! Without a door, sunlight would hit daily target every orbit in certain times of year, could not meet K1 & K2 with resulting degradation. |
| 58deg Incidence / 36deg Viewing | Compromise between: <ul style="list-style-type: none">• Accuracy of pre-launch BRDF diffuser measurement angles (avoid shallow angles)• Keeping high gain bands from saturating• Volume / mass constraints require forward scatter measurement• Minimizing slew time during solar cal maneuver• Minimizing slew angle to keep radiators out of the sun |
| Two Minute Solar Cal Collection Period | Compromise between: <ul style="list-style-type: none">• Minimizing interruption of normal science at upper latitudes• Time for spacecraft to slew and stabilize for inertial hold• Enough averaging time to reduce noise uncertainty to <0.1%• Minimize baffle length – View to Earth limb at end of maneuver (17deg) sets length |



Pre-Launch Tests



Pre-Launch Tests: Diffuser BRDF Measurements



- Absolute calibration of OCI comes from absolute knowledge of solar irradiance and solar diffuser BRDF, not the transfer of calibration from an optical source at the OCI level.
- Five diffusers were delivered by TNO, NL with BRDF measurements. One diffuser was measured at GSFC for comparison. **Generally excellent agreement.**
- Measurements made at various wavelengths, angles and locations. Polarization test on one unit. Hyperspectral / DHR measurements made on test sample. Model developed to correct for non-uniformity due to QVD volume effect.

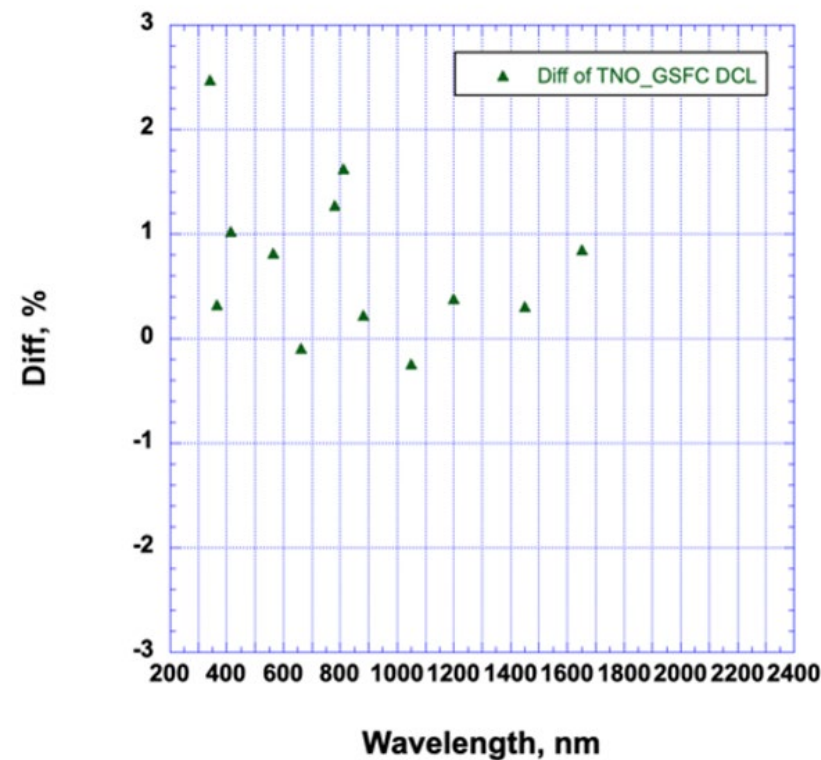
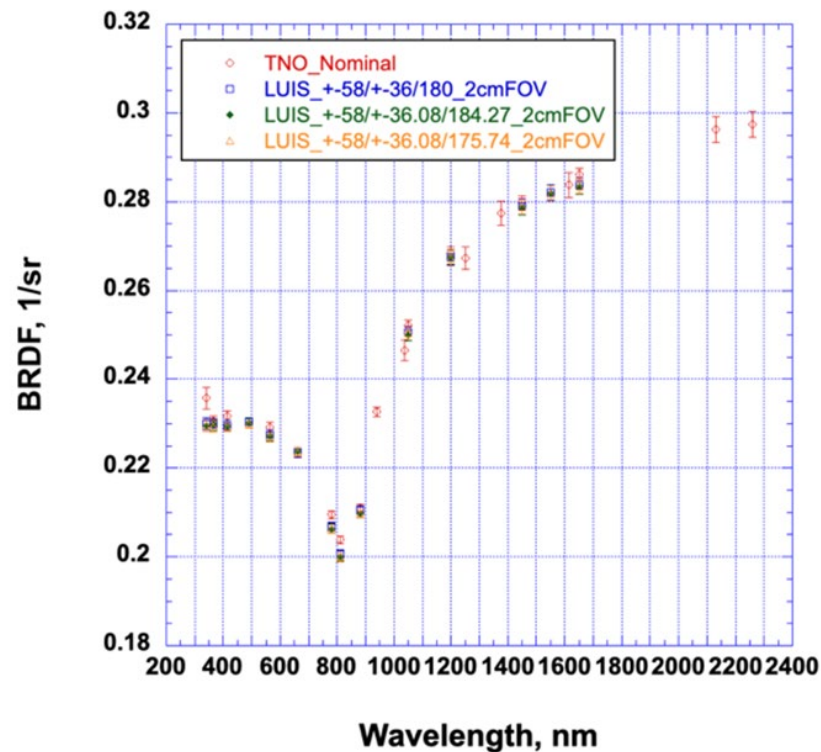

BRDF Uncertainty requirement:
Generally $\leq 1.25\%$ 1- σ



Pre-Launch Tests: SCA Tests at Full OCI Level

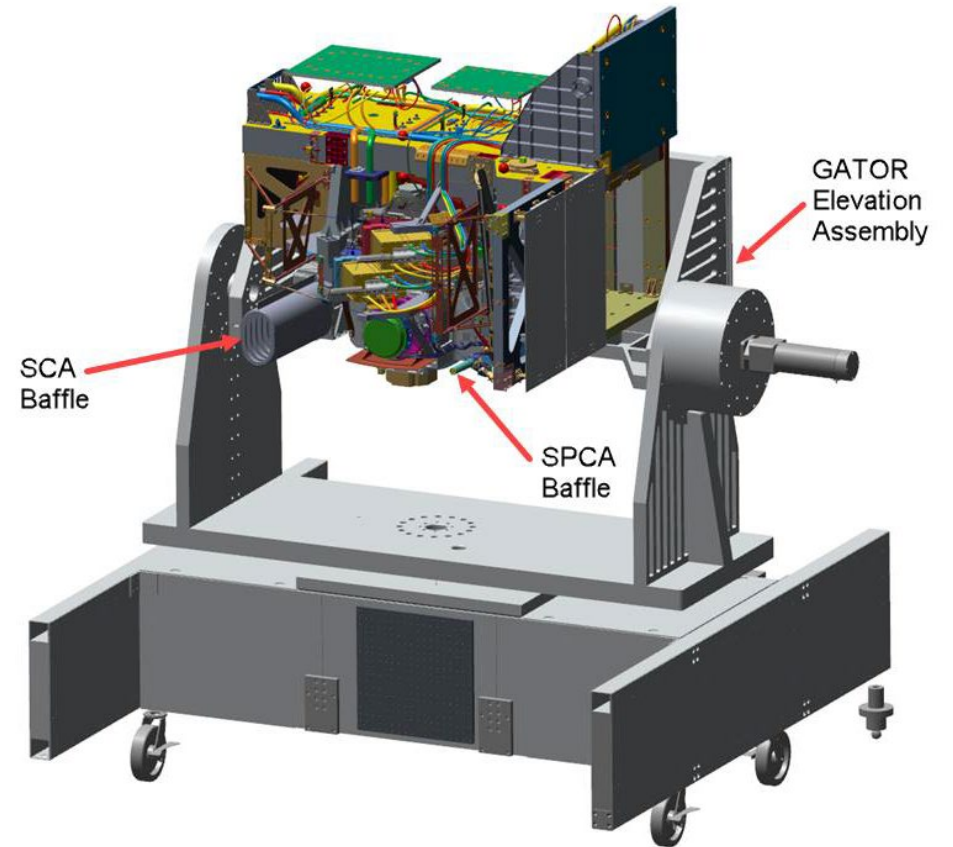
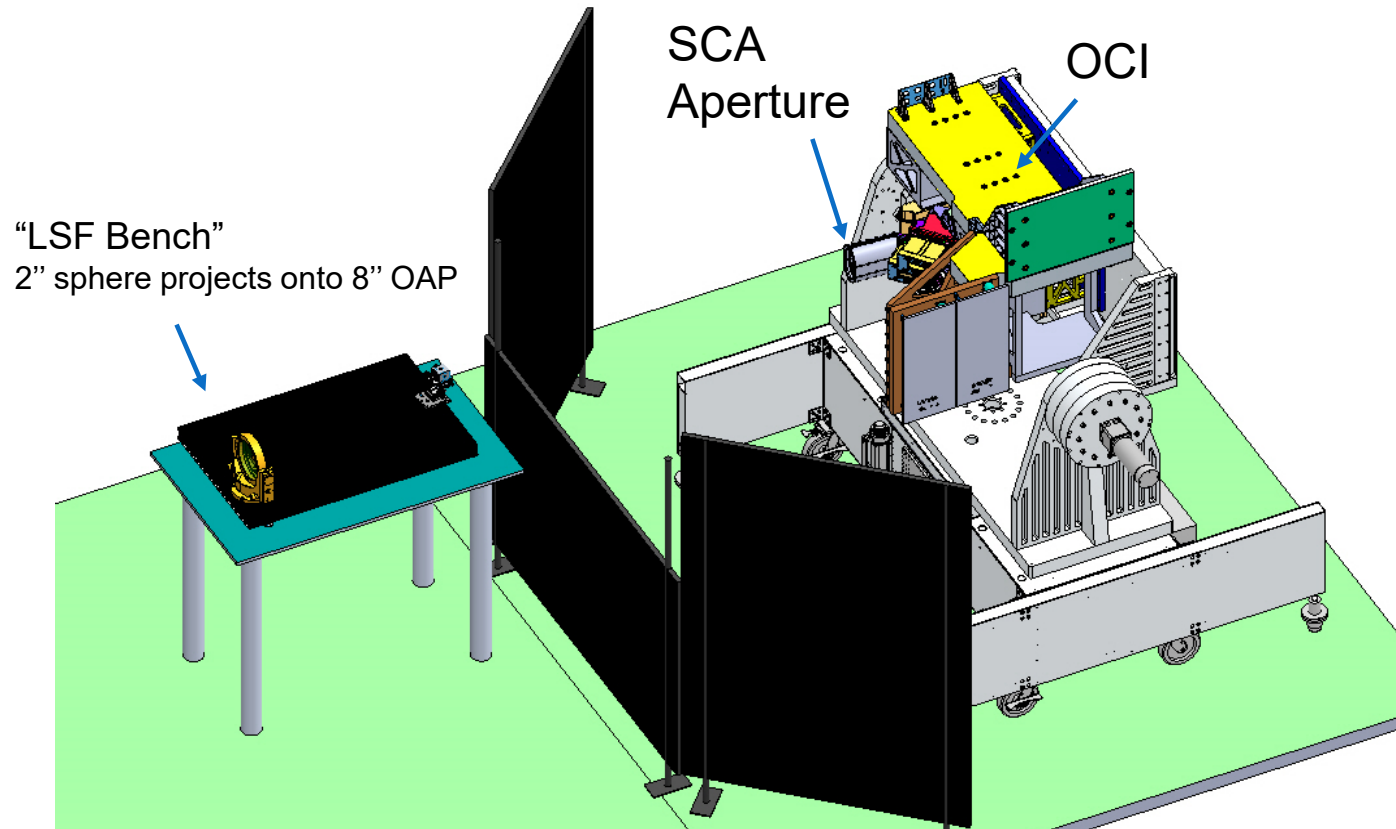

- OCI is tilted forward 90deg on GAToR so SCA the baffle is parallel to the floor.
- SCA calibration targets and baffle are illuminated with various light sources at various angles
- GOALS
 - Coarse radiometry check: signal response, plateau shape, repeatability, PTDI functionality, scan table tuning, etc.
 - Baffle stray light performance



Pre-Launch Tests: Coarse Radiometry Tests and Results



Challenge: No lab optical source matches the sun. Need broad-band, high irradiance, high uniformity.

Approach: Use several different light sources, each with advantages / disadvantages.

- Studio Lamp: *Medium irradiance, divergent source, low-uniformity, white light*
- LSF bench with halogen & UV source, no scene mask: *Low irradiance, high uniformity, white light*
- LSF bench with GLAMR no scene mask: *Med-high irradiance, high uniformity, monochromatic.*
- “Top-Hat Illuminator” Connected to LSF Bench at 638nm: *High irradiance, medium uniformity, one wavelength*

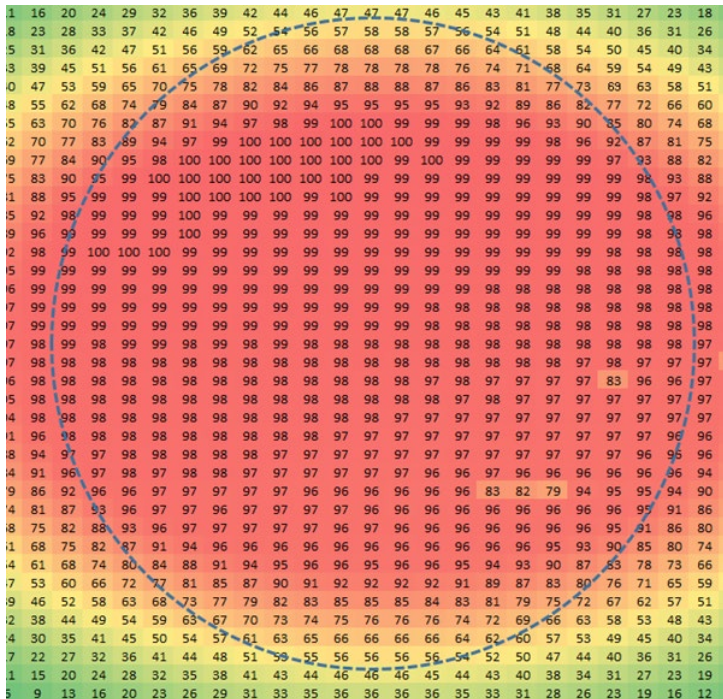

Measured uniformity of LSF bench beam w/ GLAMR at 865nm (raster scanned detectors)

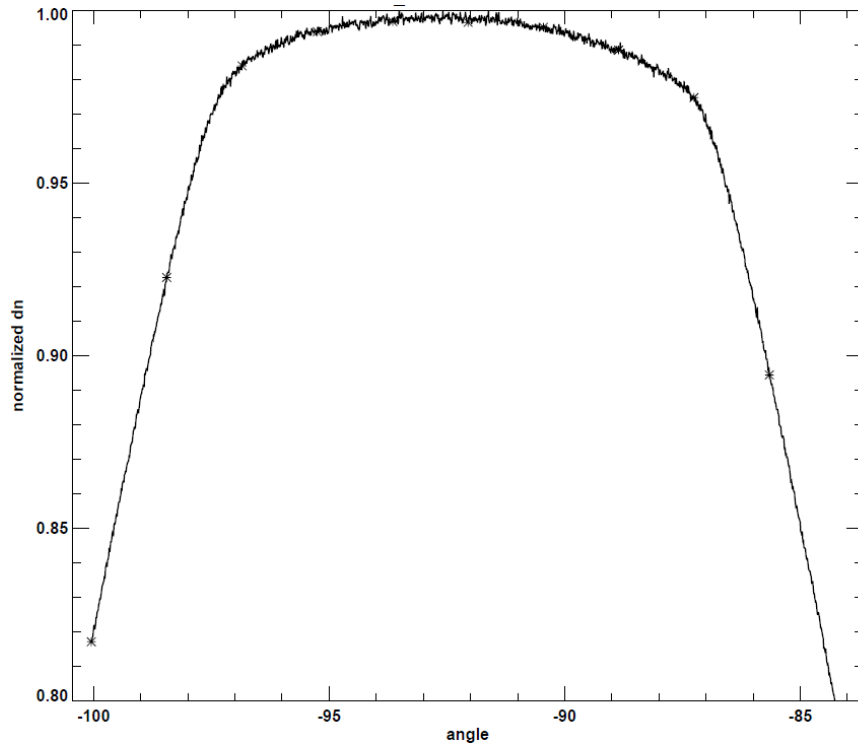

Normalized plateau shape from the beam at the left as measured by OCI

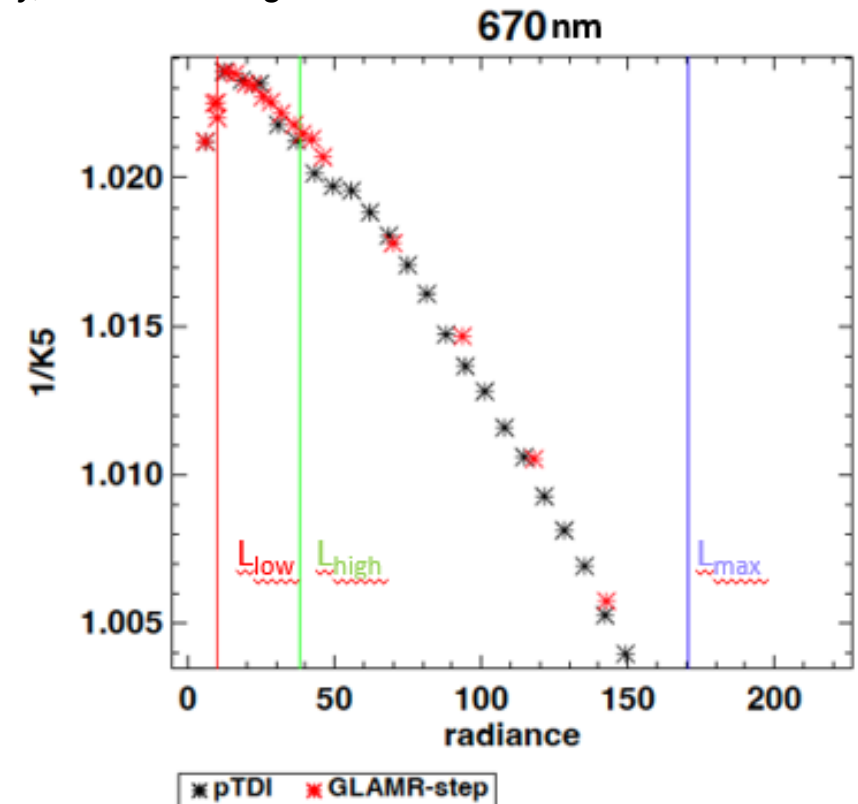

PTDI Results: Comparing Measured Non-Linearity Term from PTDI vs. Power Stepping



4 Stray Light Sources Considered

4) Scatter from S/C, OCI from 1) and 2)

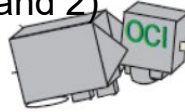

3) Effect of ACS on 2)

2) Direct Sun Scatter (Inside SCA)

Top of Atmosphere 1° above Earth Limb



1) Earth Shine Both Specular Atmosphere & Diffuse Atmosphere Investigated



Detail: Solar Cal Assembly Viewing the Sun

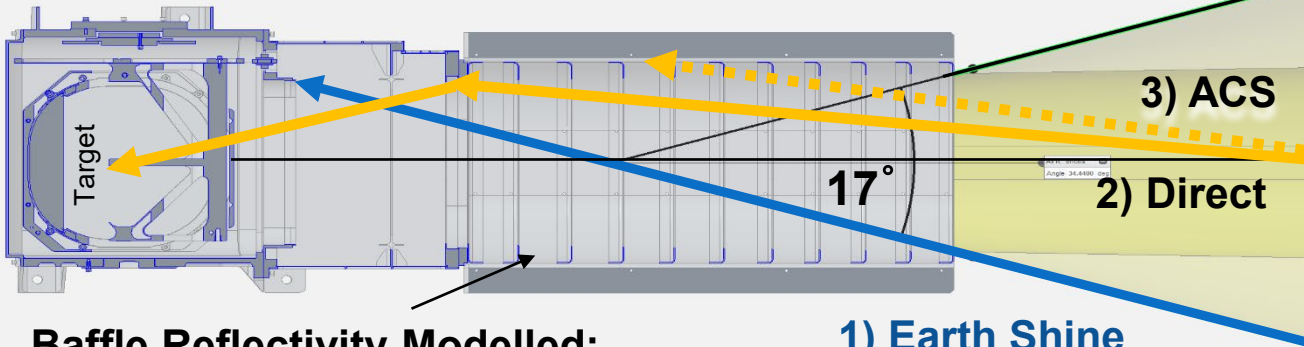

Baffle Reflectivity Modelled:

Used Measured Carbon Fiber BRDF & White Diffuse to Simulate UV Bleaching (4th order FRED model.)

1) Earth Shine

Baffle Length Designed at Completion of 2min Cal (17° to ToA)

Stray Light Requirements and Modelling Results

Power Incident on Diffuser Point Source Scan

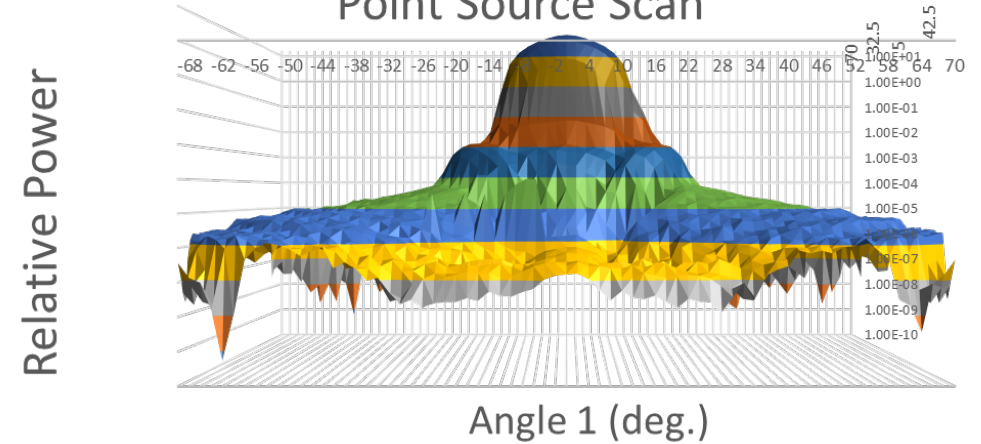

- Requirement: $\leq 0.3\%$ at any wavelength
- Prediction from Model: **0.09%**
 - Combes all sources to the left at worst-case wavelength and component reflectivity assumptions.
 - For Earth-shine, perfect glint assumed.



Pre-Launch Stray Light Measurement Tests

Method: Rotate source about the baffle entrance: however, GAToR does not tilt/rotate about the SCA aperture. Sources need to be manually translated or elevated to maintain alignment to baffle entrance as GAToR moves.

Elevation Tests

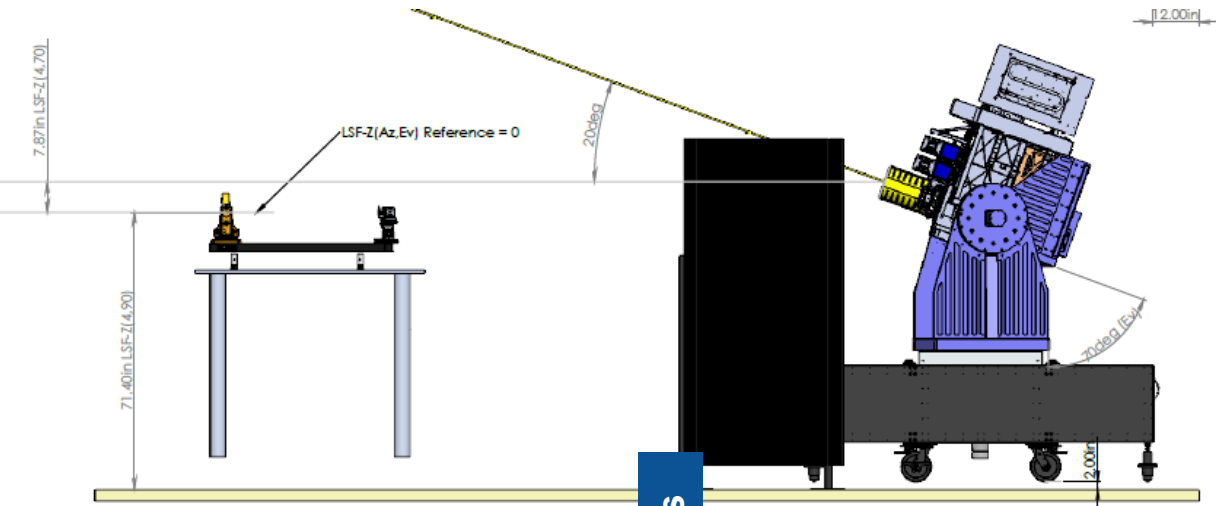

Azimuth Tests

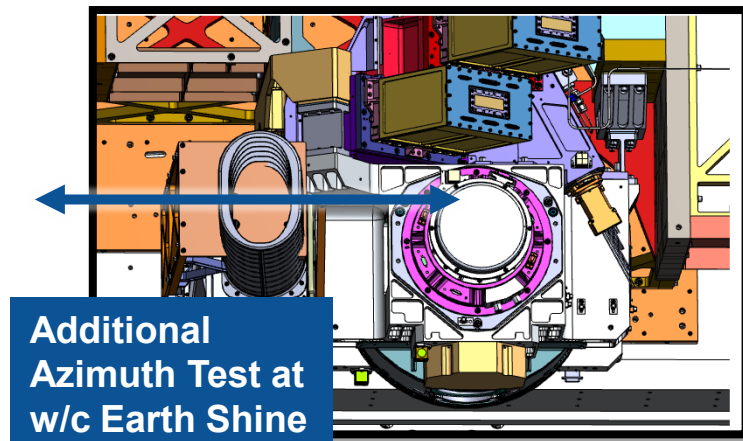
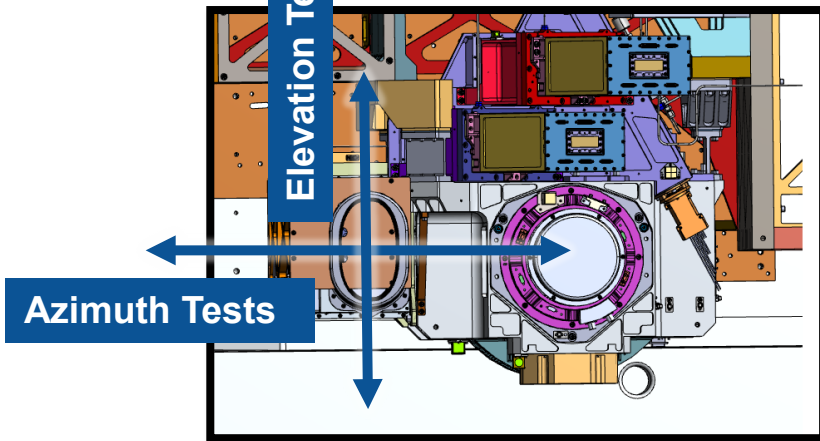
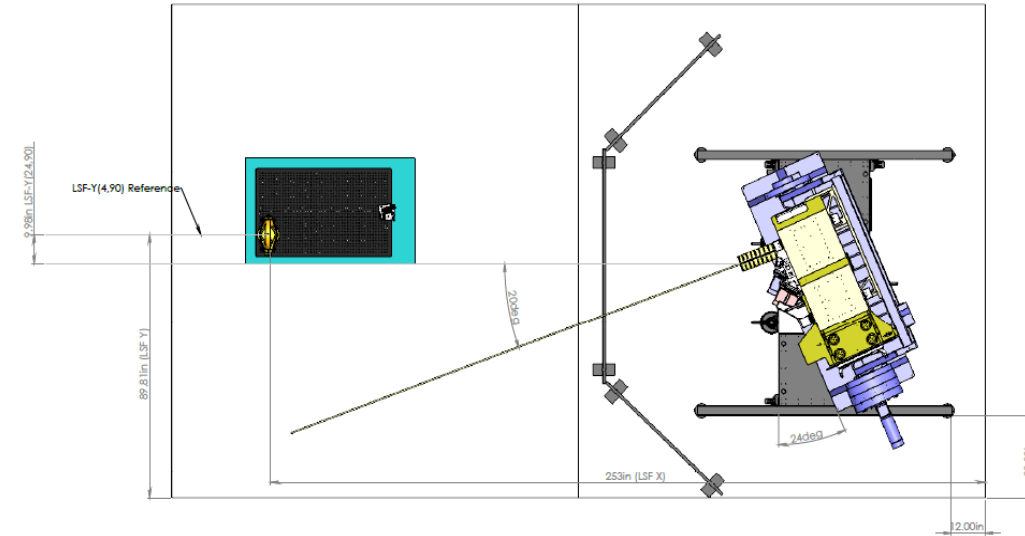



Stray Light Test Results: Modelled vs. Measured



Elevation Results

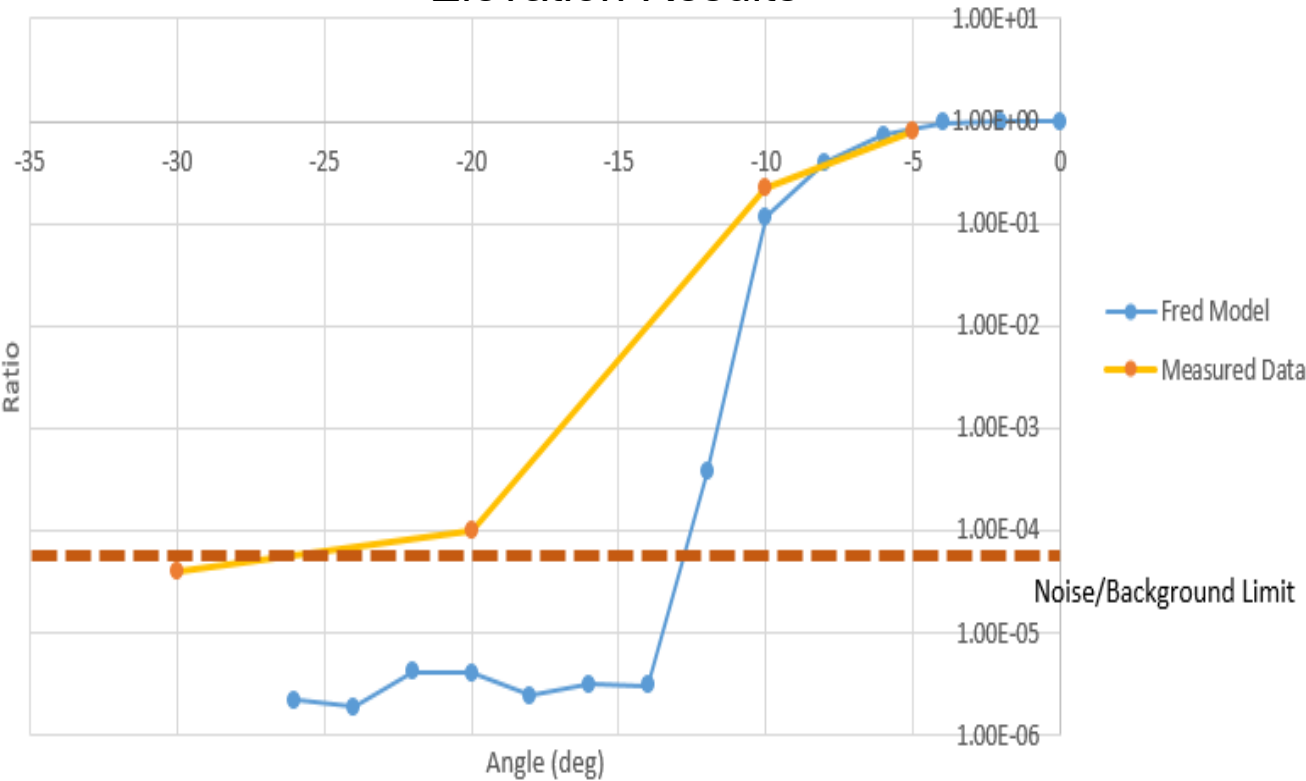

Azimuth Results

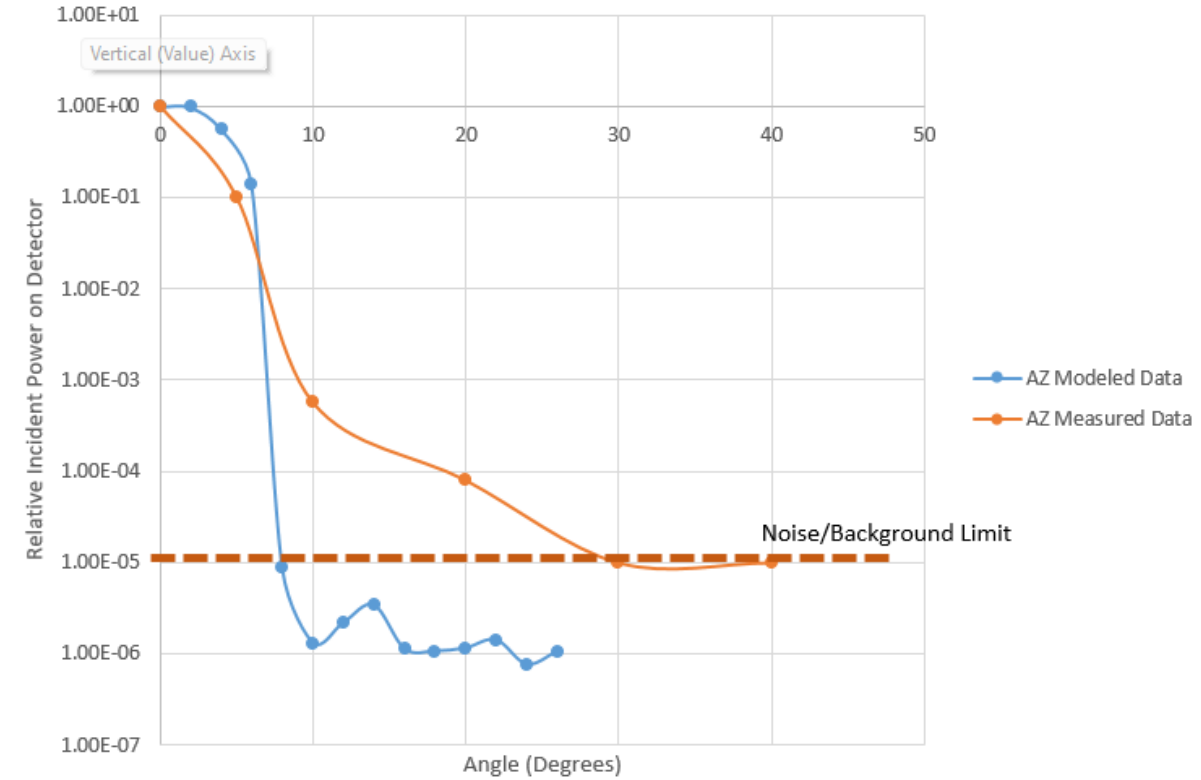

- Model and measurements agree well at low angles.
- At higher angles some divergence, possibly from modelling challenges of baffle vane edges, and BRDF at steep angles.
- No “surprise” glint found.
- **Model is reasonably validated, SCA stray light requirements likely met**



Preliminary On-Orbit Results



Preliminary On-Orbit Results



Measured vs. Predicted Solar Spectral Radiance (Using Pre-Launch K1 from GLAMR)

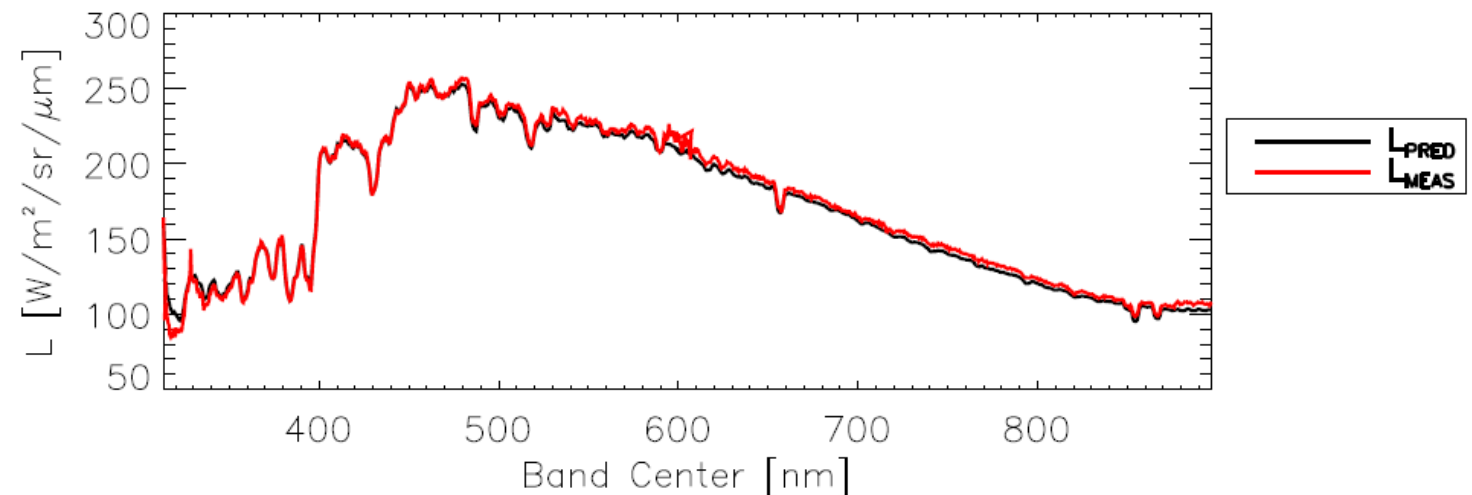

% Difference of Above Plots

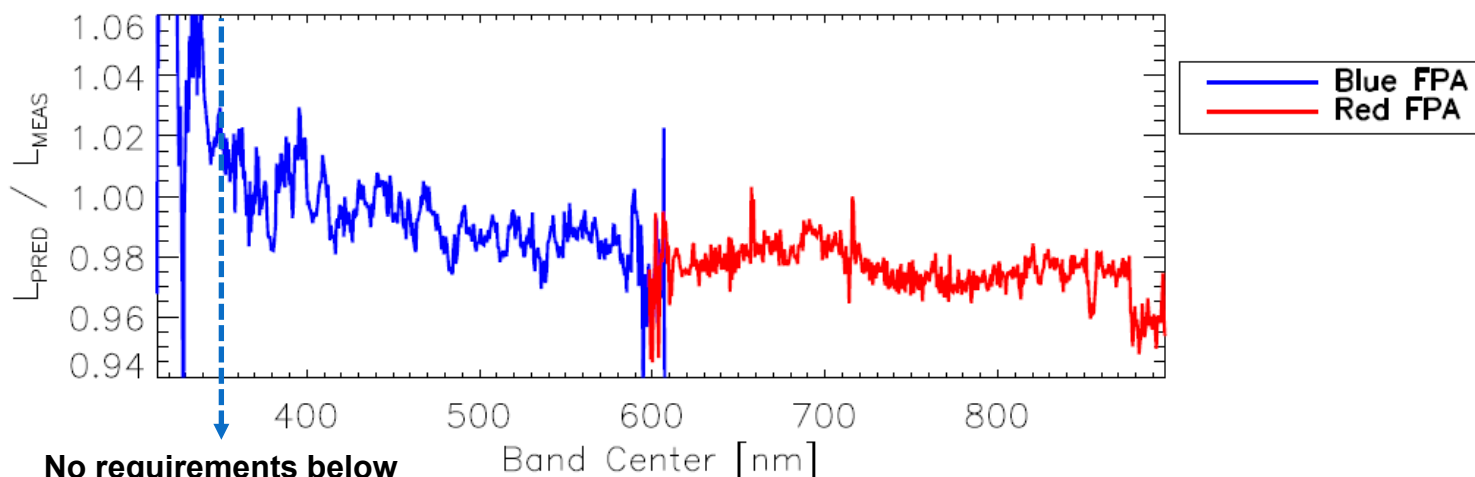

No requirements below
340nm

Measured Plateau Response

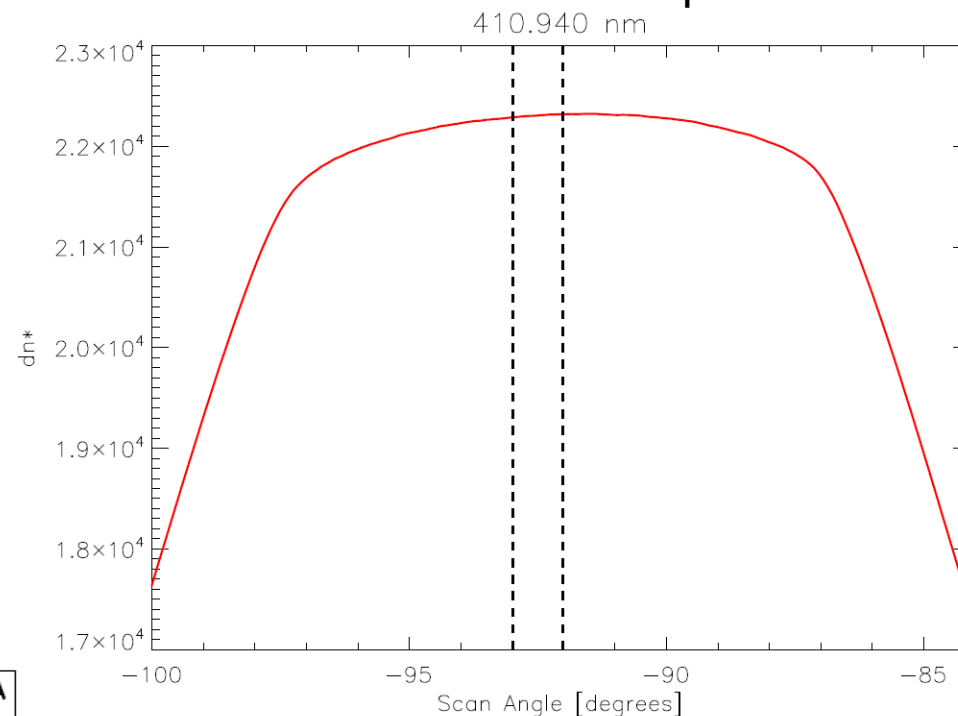

- Preliminary results show excellent agreement with predicts. No major error from BRDF, stray light or other sources.
- Plateau response agrees well with test
- UV and SWIR analyses on-going.
- Final uncertainty analyses on-going.
- PTDI analyses on going.



Questions?

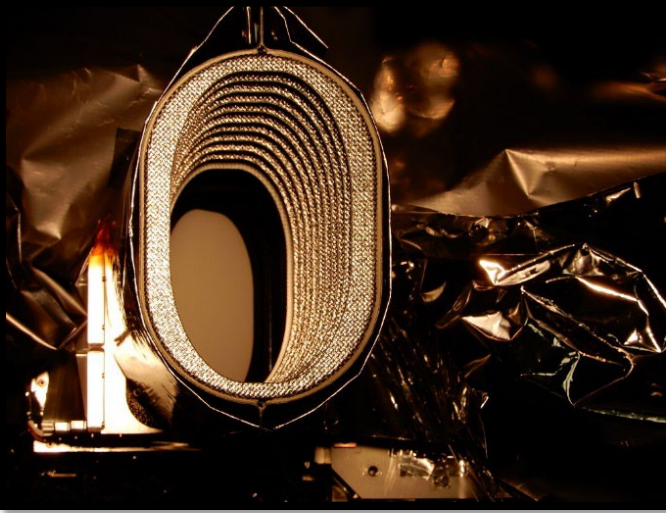
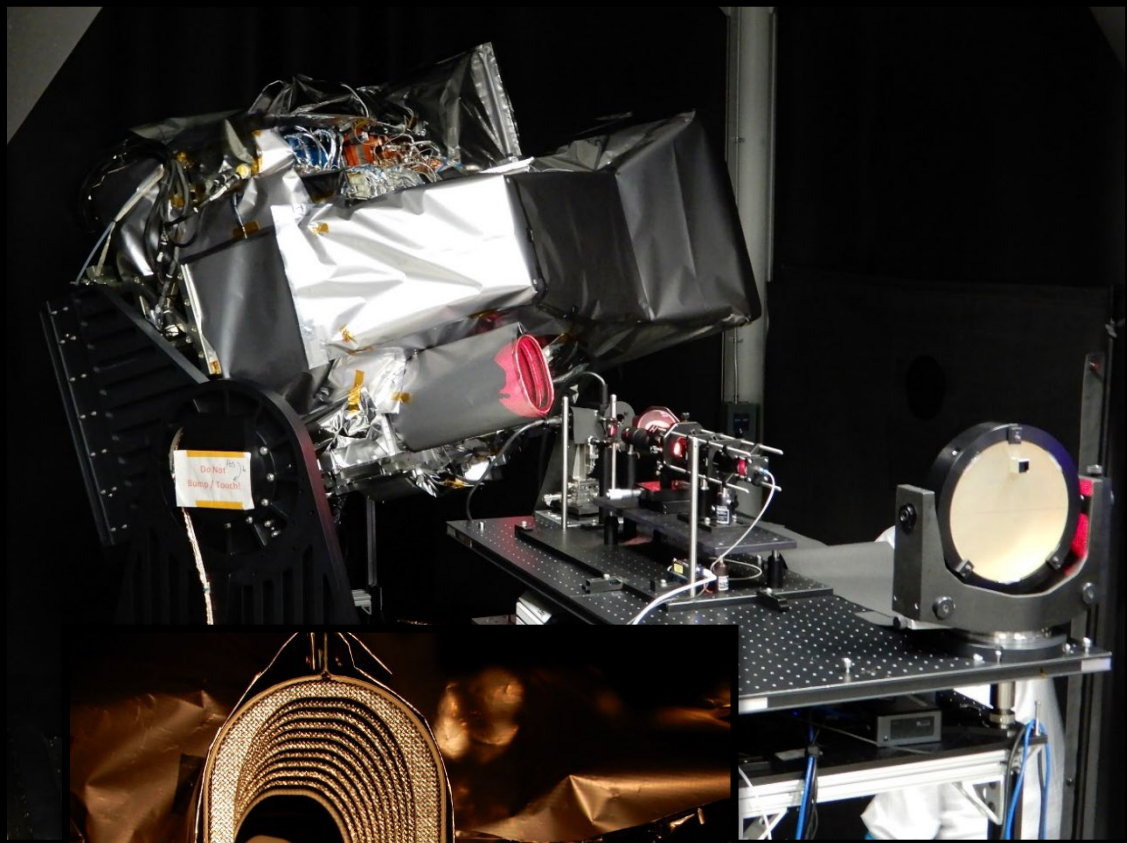

For more info, see our SPIE conference paper: Joseph Knuble et al.



OCI First Light!

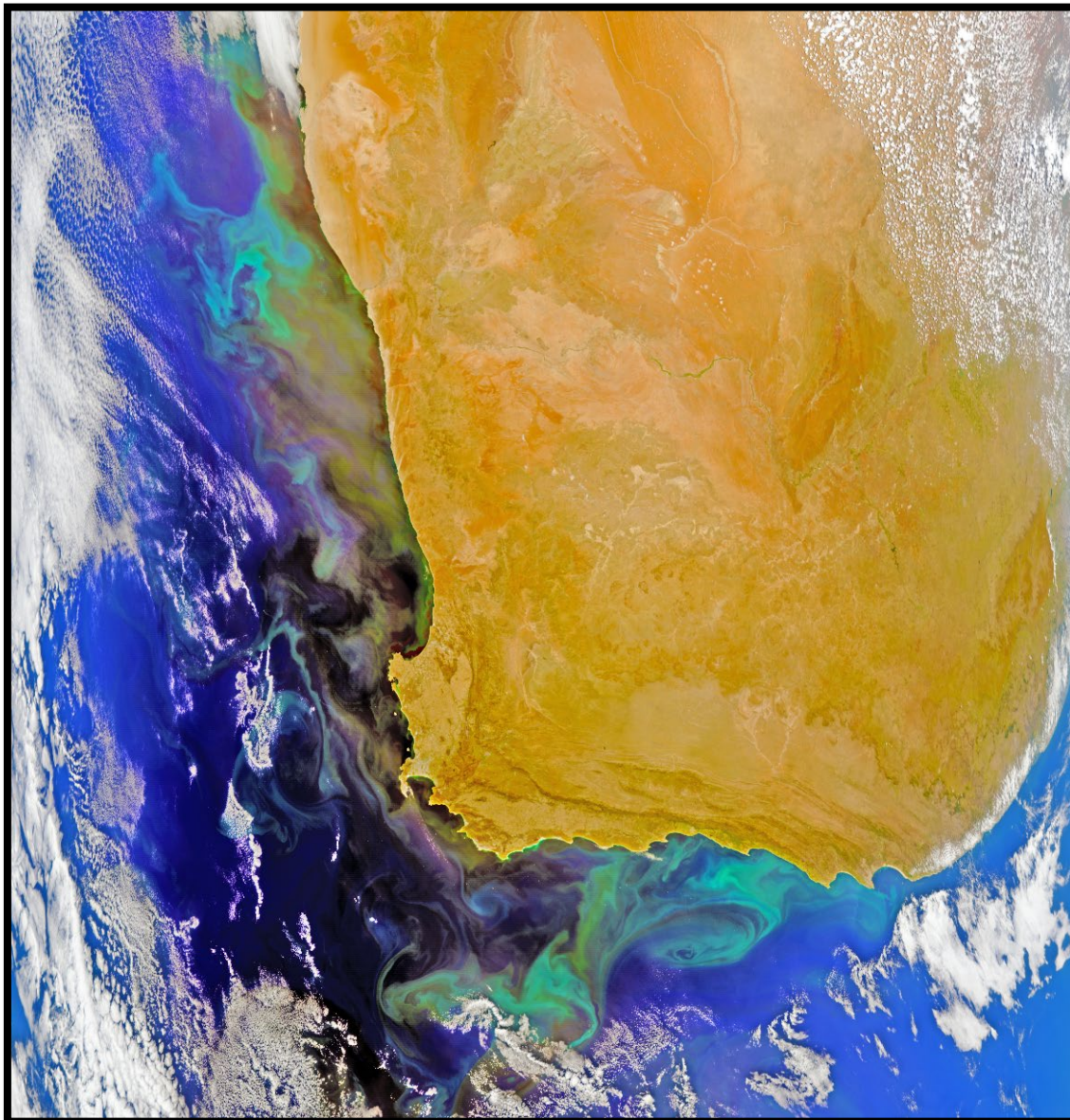



Backup



| Overall OCI Summary | |
|-------------------------------------|---|
| Instrument Mass | 267 kg CBE , 305 kg NTE |
| Instrument Power | 297 W CBE , Orbital Average |
| Mechanisms | Rotating Telescope Mechanism (~6Hz) Half Angle Mirror Mechanism (~3Hz) Solar Calibration Mechanism (5000 Cycle) |
| Ground Sample Distance | 1060m at Nadir |
| Aperture | 93mm |
| iFOV | 0.08° Along Track x 1.42° Cross Track |
| UVNIR System EFL | 0.132m |
| UVNIR System f/no | 1.42 |
| Total Field of Regard | +/- 56.5° |
| Dynamic Range | SNR at L_{typ} , No Saturation at L_{max} |
| UVNIR Bands (nm) | 342.5nm – 887.5nm , 5nm Resolution |
| NIRSWIR Bands (nm) | 940, 1038, 1250, 1378, 1615, 2130, 2260 |
| UVVIS & VISNIR FPAs | 2 CCDs, 128 x 512, 26 micron Integrated 14 Bit ADC |
| NIRSWIR FPAs | 16MCT/16InGaAs Photodiodes, < 250 micron analog output to SIDECAR ASIC |
| SNR @ L_{typ} | > 1000:1: 340 – 700nm > 600:1: 700 – 865nm > 50:1 940 – 2260nm |
| On-Board Solar Calibration Assembly | Daily & Monthly Solar Calibration Targets SWIR Solar Calibration Telescope |
| Orbital Average Data Rate | 13 Mbps up to 40 Mbps |