

3D Printed Antenna for a Balloon Test Flight

Dr. Margaret H. Samuels

NASA Goddard Space Flight Center

GE Aerospace LEAD Symposium - Oct 1, 2024



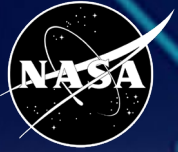

NASA GSFC 3D Printing Electronics Group



Overarching goal: Demonstrate capability for 3D Printing electronics to both **maximize customization** for unique needs of spaceflight missions while **minimizing cost and schedule**.

We plan to accomplish this via two prongs:

- 1. Research:** applications for spaceflight projects with unique needs
- 2. Rapid prototyping:** helping low-risk missions prototyping boards and other electronics early, enabling earlier testing and addressing design flaws



Past work

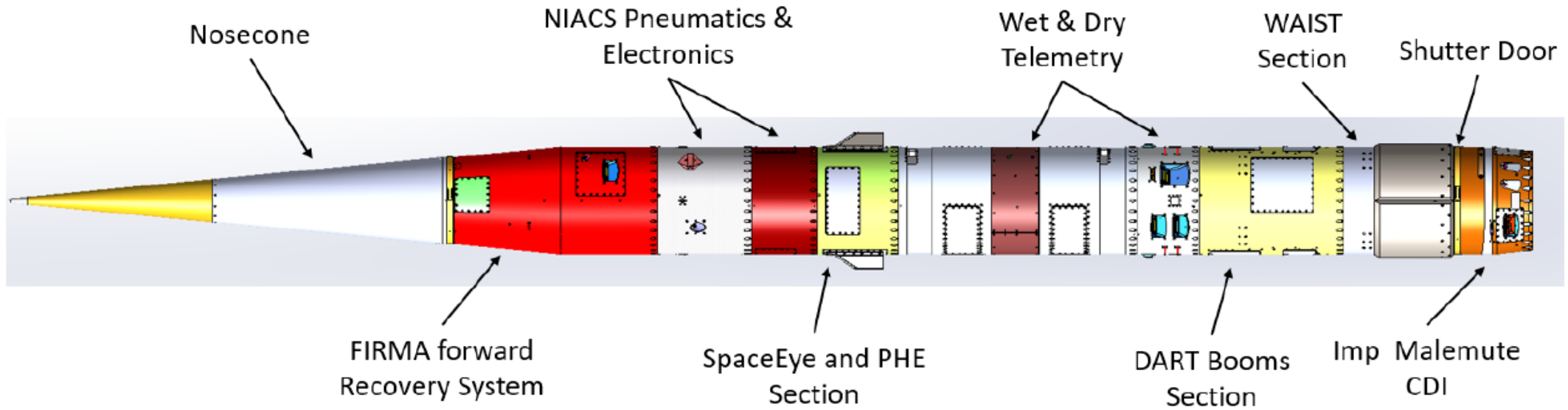
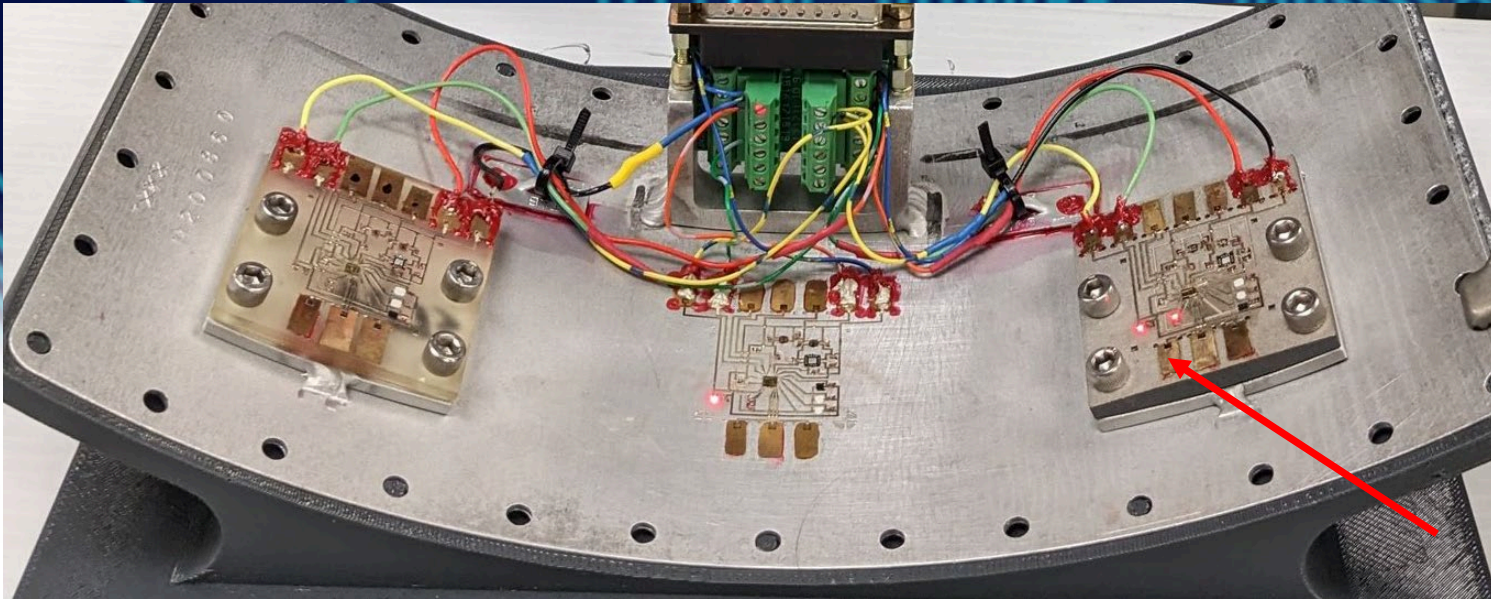

April 2023 SubTec-9 Sounding Rocket Demonstration

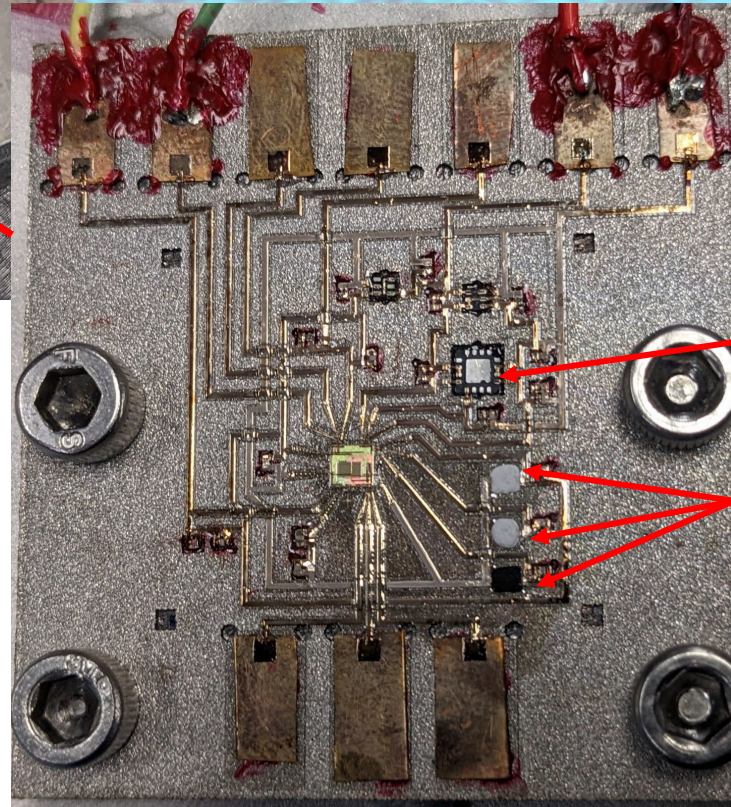
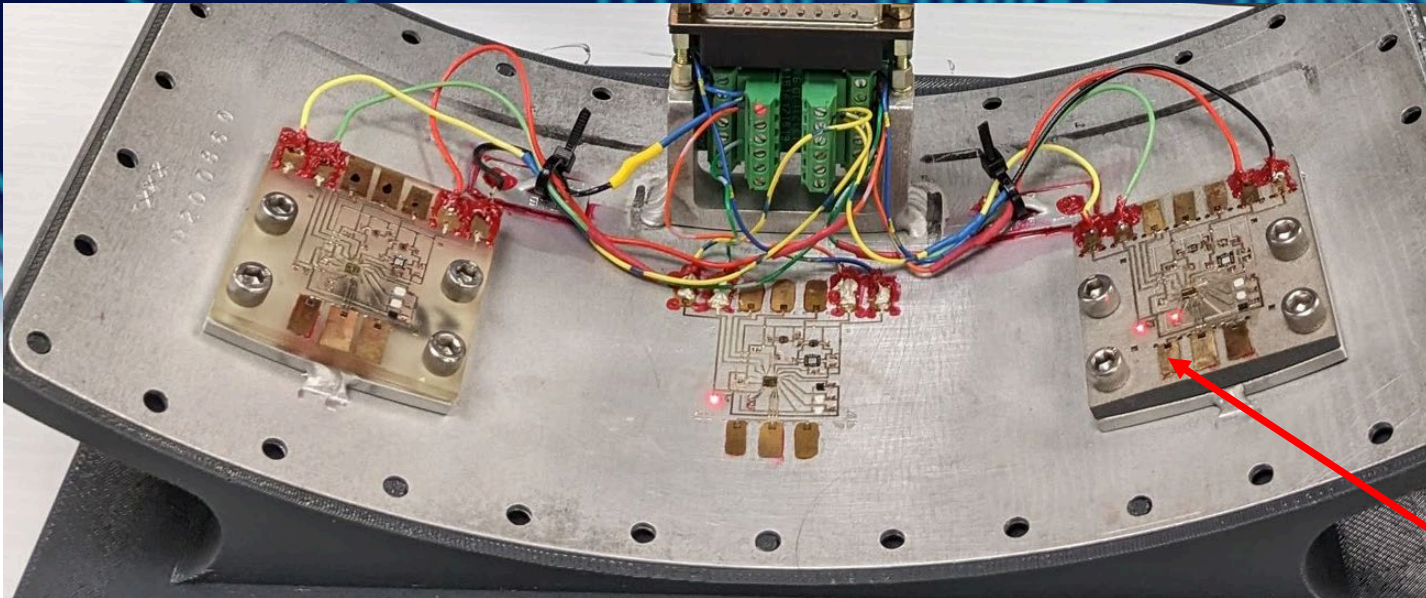

Accelerometer
Printed
Temperature and
Humidity Sensors

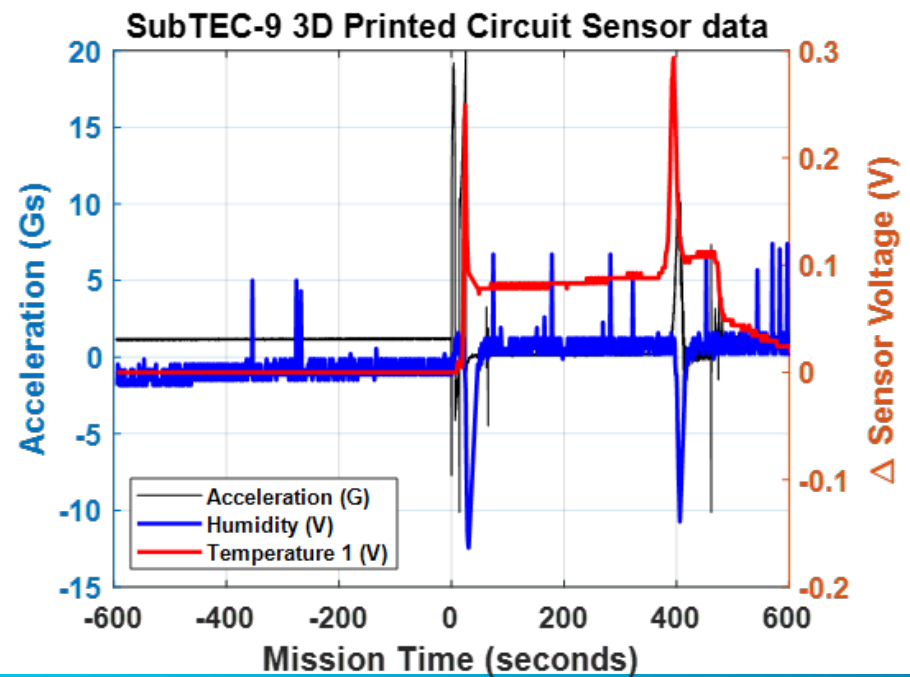

April 2023 SubTec-9 Sounding Rocket Demonstration

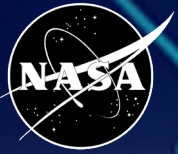

GPS transmission lines

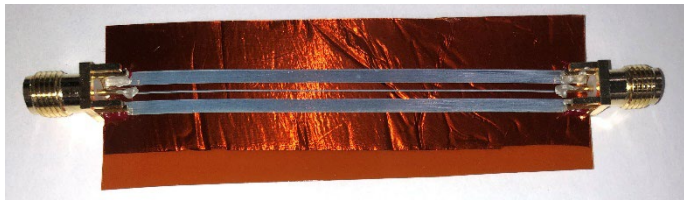
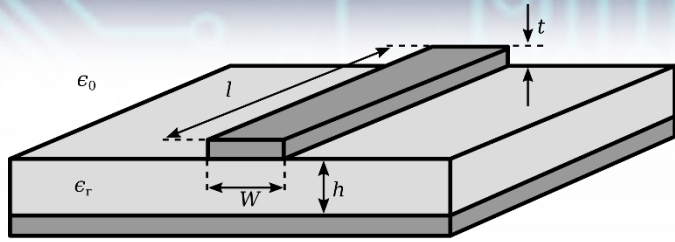

Scattering Parameter S_{11} (Signal Reflection) of an Aerosol-Jet Printed GPS Transmission Line

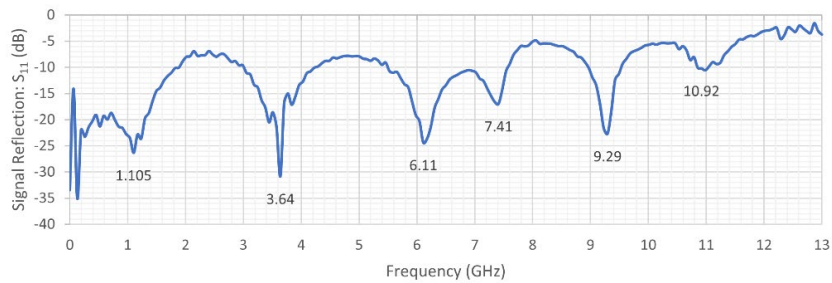

Interdigitated supercapacitors

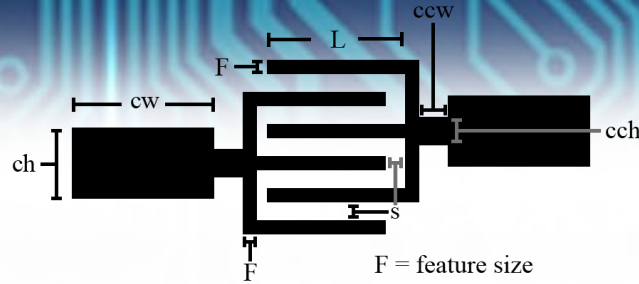

F = feature size
L = length
s = spacing
ccw = current collector width
cch = current collector height
cw = contact width
ch = contact height

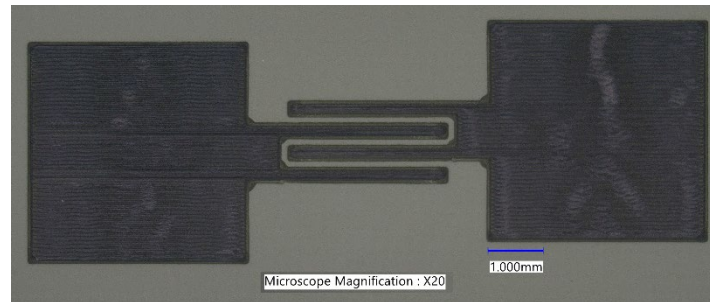
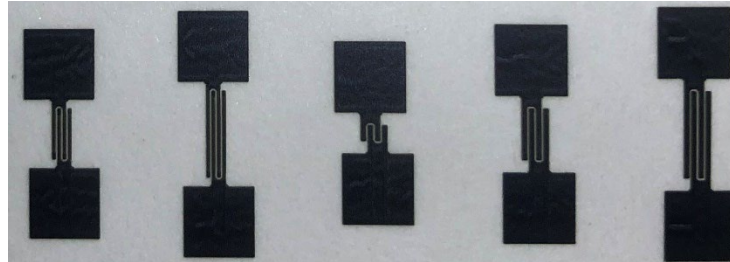

Printed interconnects: a wire bonding alternative

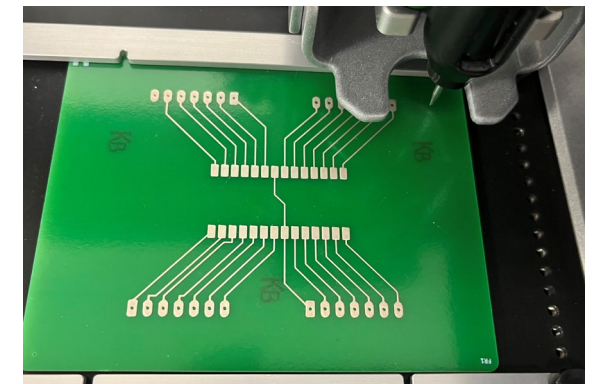
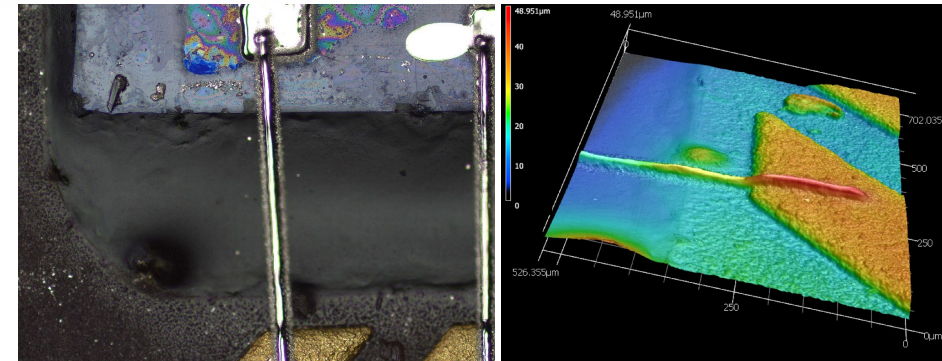



Current work



“Development of 3D Hard X-ray Photoelectric Polarimeter Assembly Using Additive Manufacturing Technology”

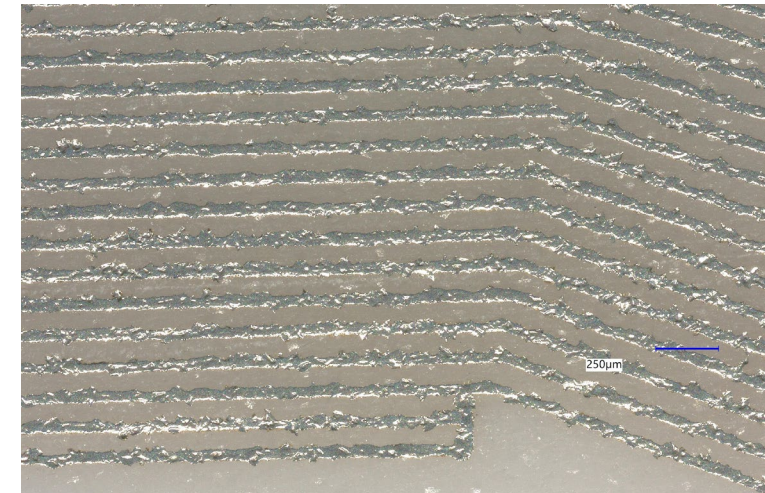
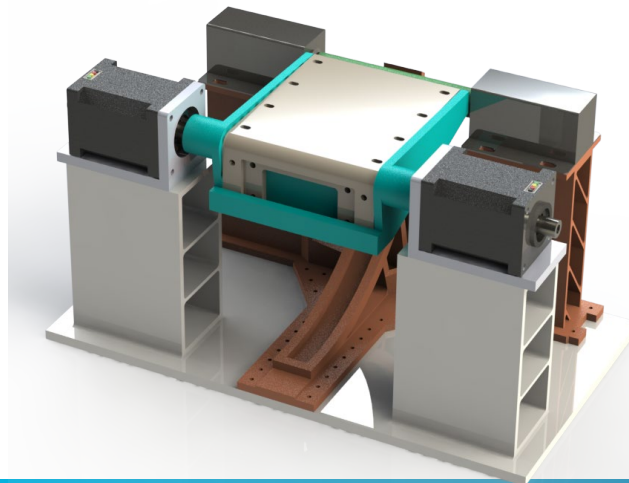
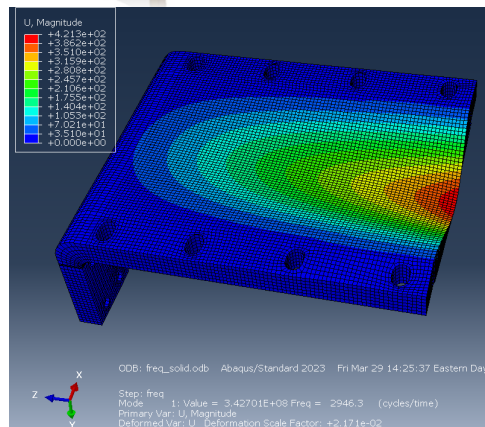
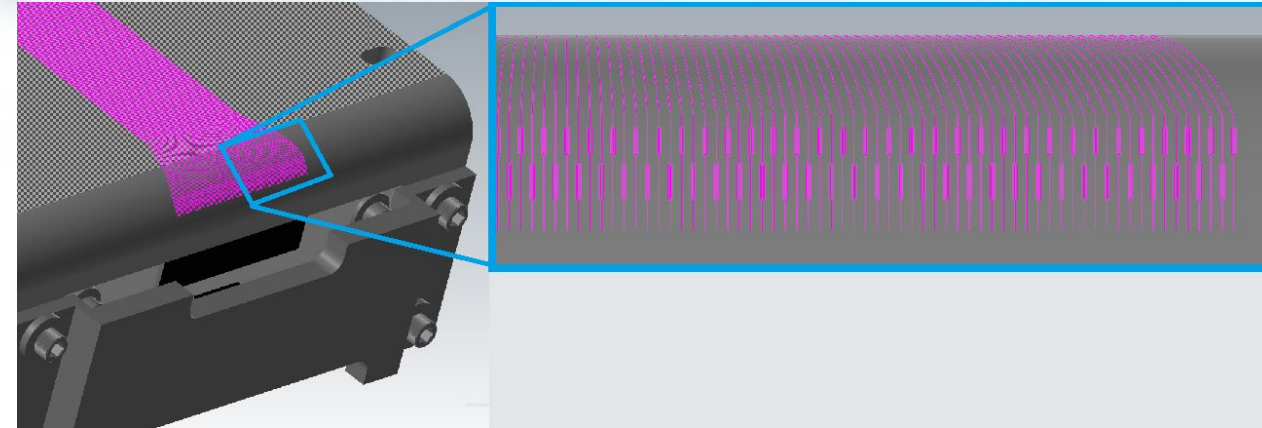
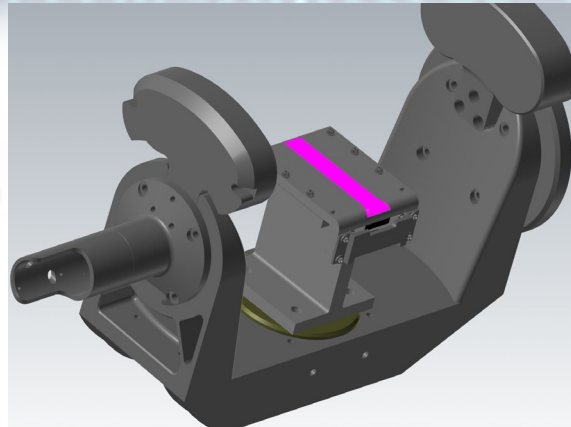
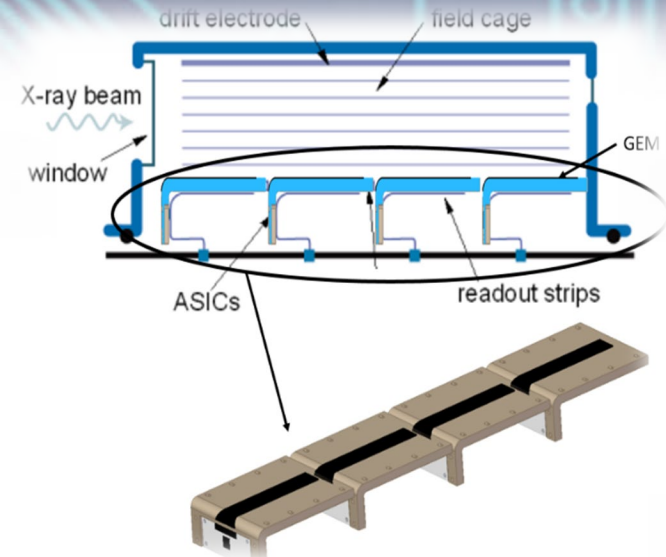

Mode 1: 2946.3Hz

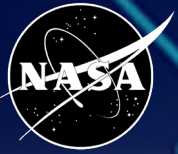

“Printed strain gauge for Sounding rocket boom measurements”



- Printing strain gauges on ends of ½” diameter fiberglass tube – measure displacement due to wind velocity
- Initial prints with Ag ink yielded resistance of 400 – 500 Ohms → *Need resistive inks*
- Design strain gauge with:
 - Adhesion (ASTM testing)
 - 1 kOhm resistance
 - 10^{-6} sensitivity

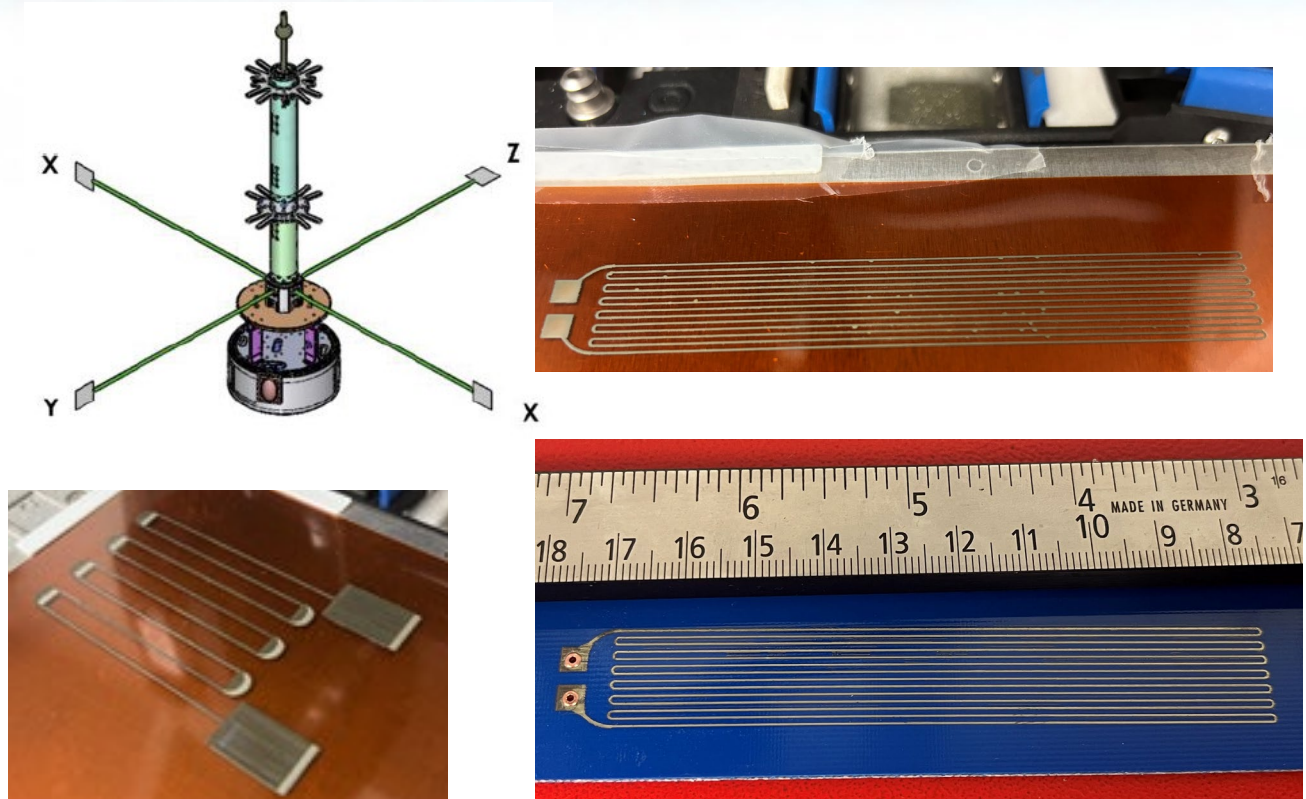

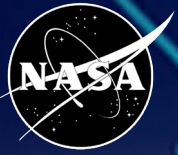

“Automated Design and Placement of Printed Hybrid Electronics on Non-Traditional Surfaces”

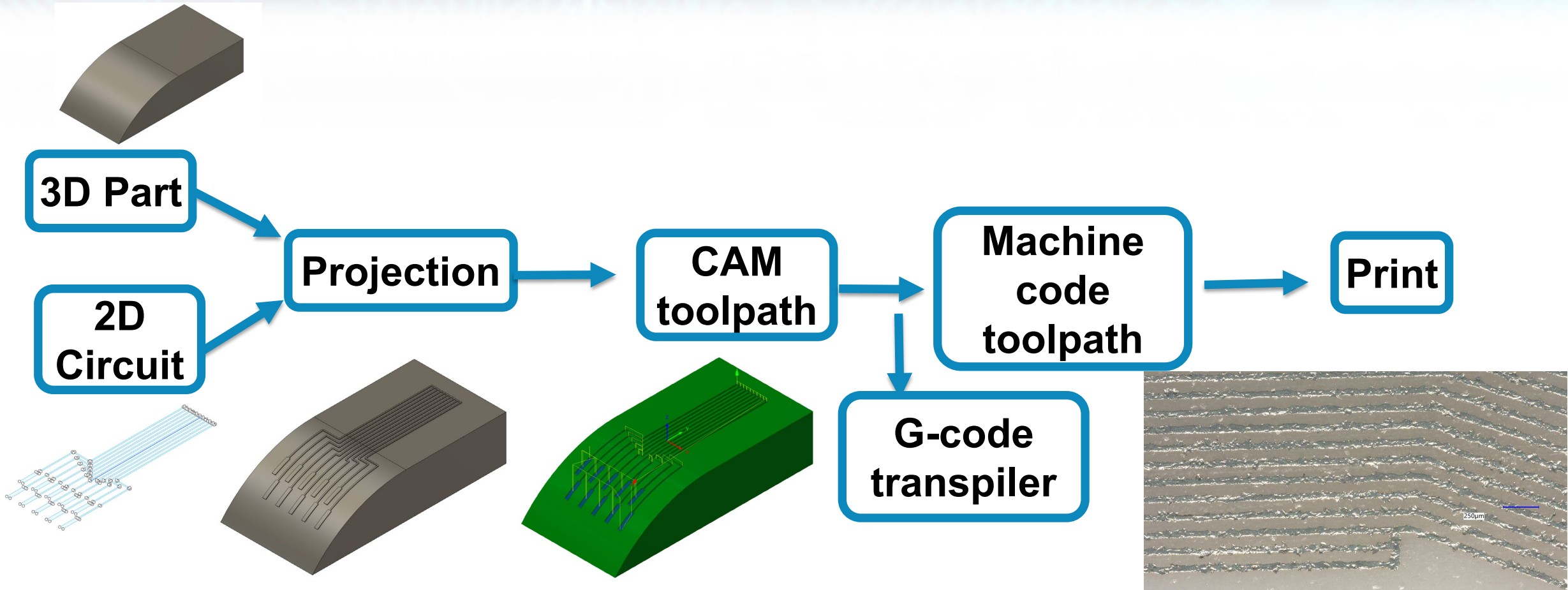

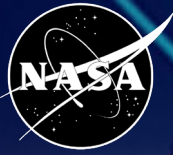

“Automated Design and Placement of Printed Hybrid Electronics on Non-Traditional Surfaces”

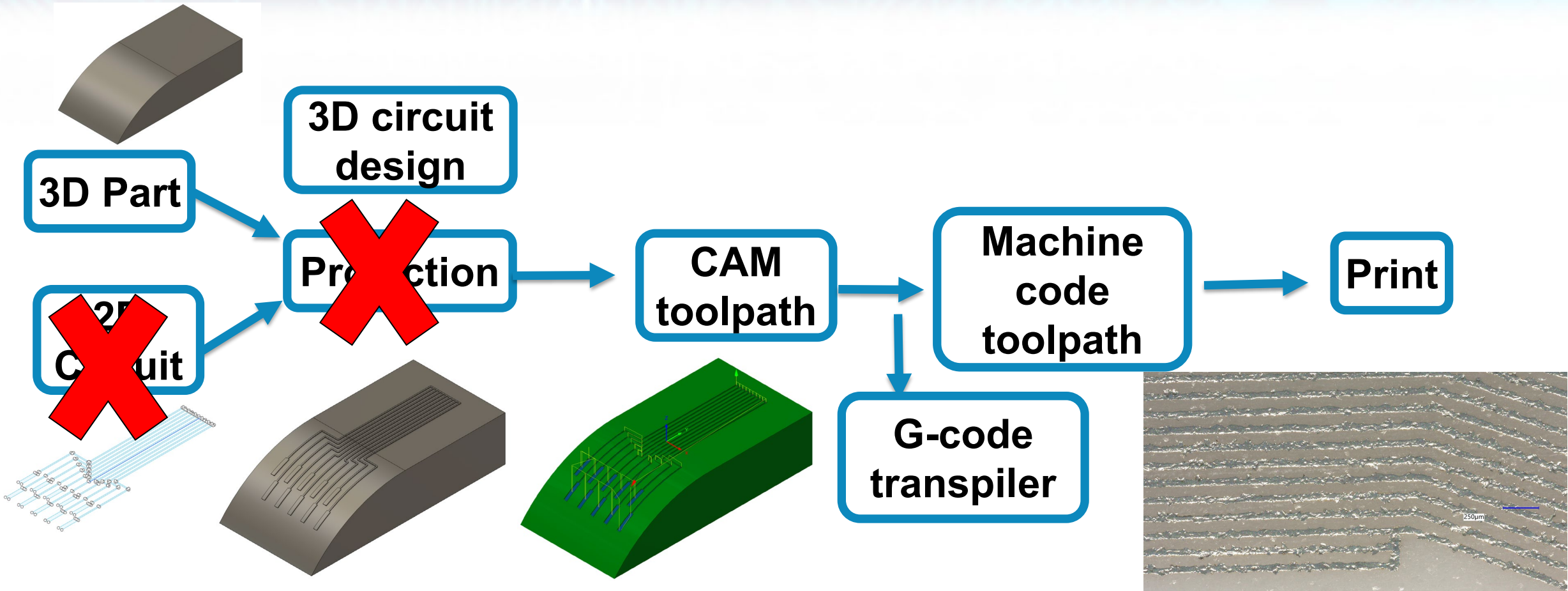

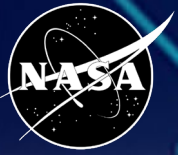

3D Printing Electronics Laboratory

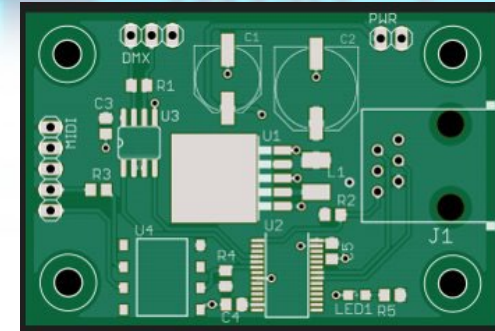
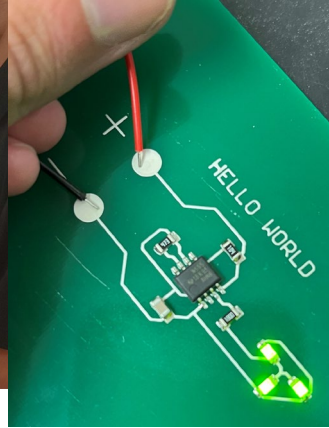
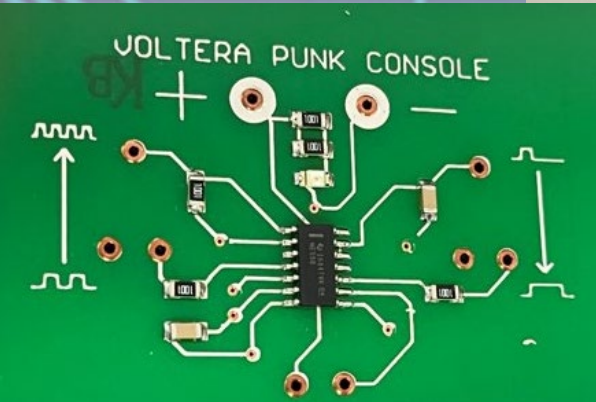

Voltera V-One

- Min. line width: $200\ \mu\text{m}$
- Hole drilling:
 - $0.4\ \text{mm}$ diameter rivets
 - $1.0\ \text{mm}$ diameter rivets
- Ag-based conductive ink for traces and pads
- Reflow soldering built in
 - Sn42Bi57.6Ag0.4
- Also hand solderable

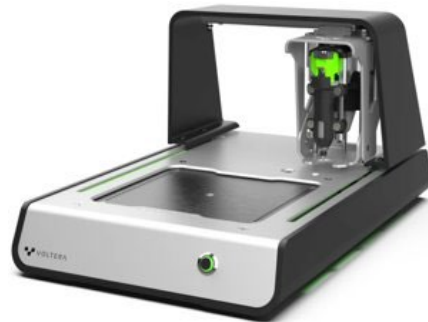

Botfactory SV2 Professional

- Min. line width: $200\ \mu\text{m}$
- *Conducting and Insulating ink*
- Up to *6 layers* in a single print
- *Pick and Place*
- Reflow soldering built in
- Expected Resistance performance
- For a single printed layer ($40\ \text{m}\Omega/\text{sq}$):

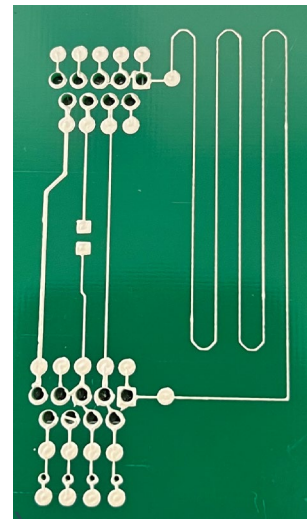

	Line width (μm)			
	250	500	1000	2000
Expected Resistance ($\text{m}\Omega/\text{mm}$)	10	20	40	12 80

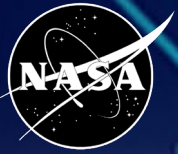

3D Printing Electronics Laboratory: coming soon

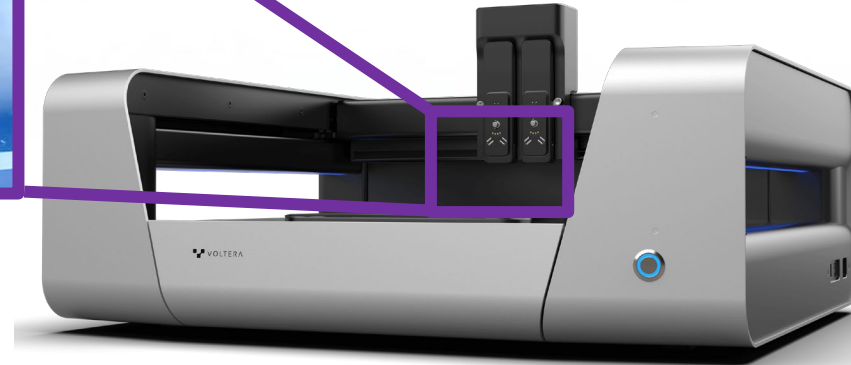
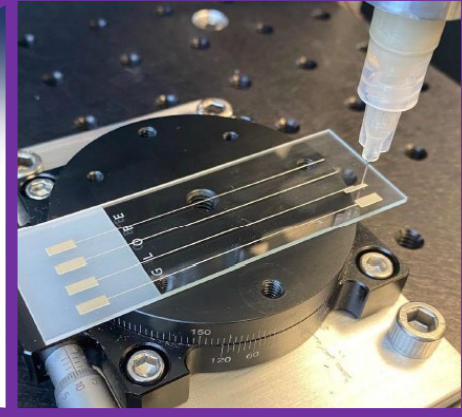
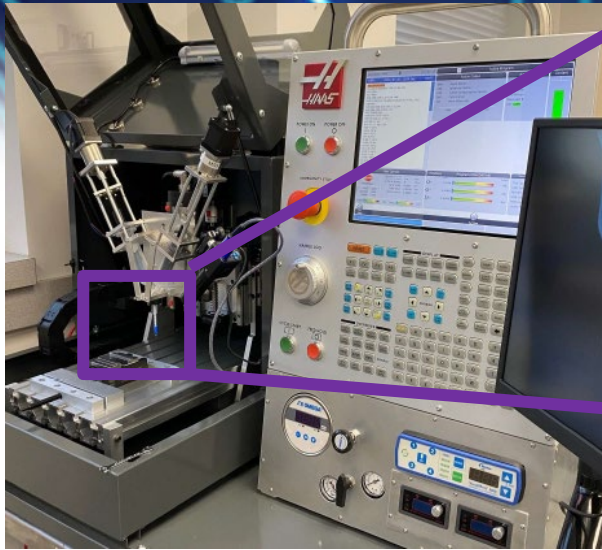

3D Flexible Tabletop

- Min. line width: $100\ \mu\text{m}$
- Additive and subtractive capabilities (milling, laser cutting)
- Direct Ink Write
- 3-axis printing
- Prints conductive, insulating, ceramic, custom inks
- Multiple print head controls

Voltera NOVA

- Min. line width: $100\ \mu\text{m}$
- *Conducting and Insulating ink*
- Up to *6 layers* in a single print
- Direct Ink Write
- Up to 30° curved surface prints
- Prints customized inks
- Multiple print heads
- Modular print heads for future adaptability



FY24 IRAD: 3D Printed antenna for a balloon flight

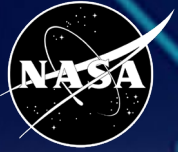

Scientific Balloon Program



- Balloon program is run from Wallops Flight Facility in Virginia
- 10 – 15 launches per year
- Launch sites include:
 - Fort Sumner, NM
 - Sweden
 - New Zealand
 - Antarctica
- For more information about the missions:
<https://www.nasa.gov/scientificballoons/>



Balloon Payload Configuration - Salter Test Flight

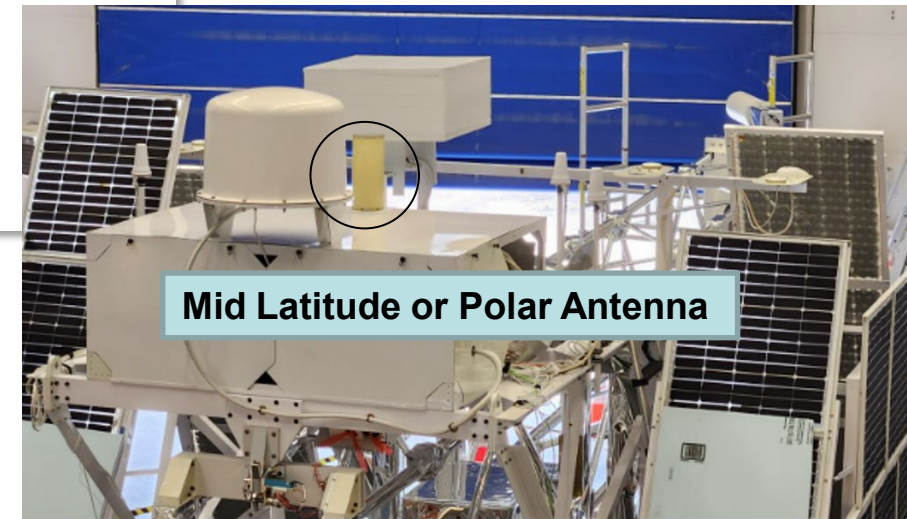
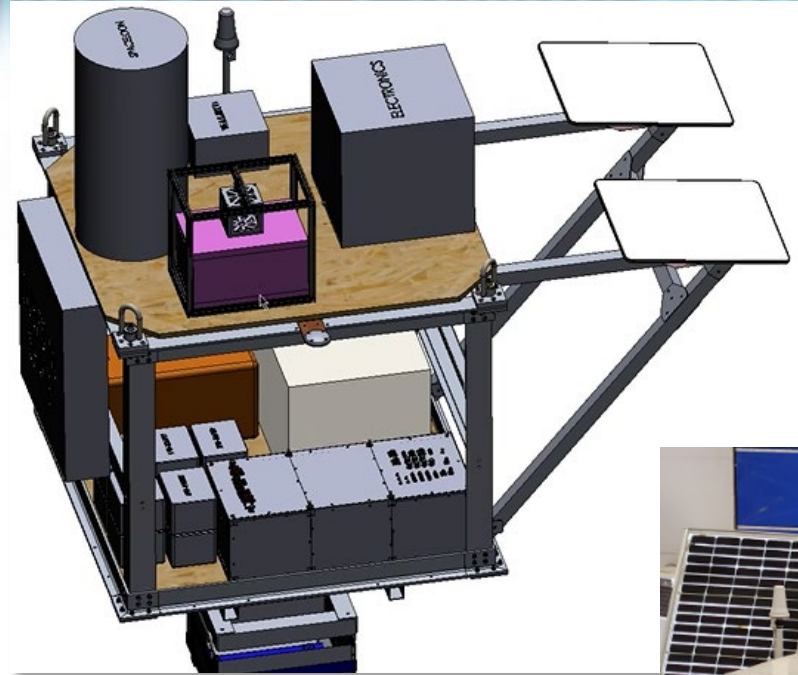

Balloon Deployment

Gondola for the Salter Test Flight

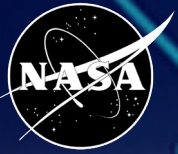

FY24 Antenna on Balloon Flight Goals

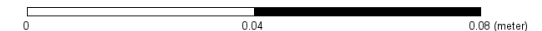
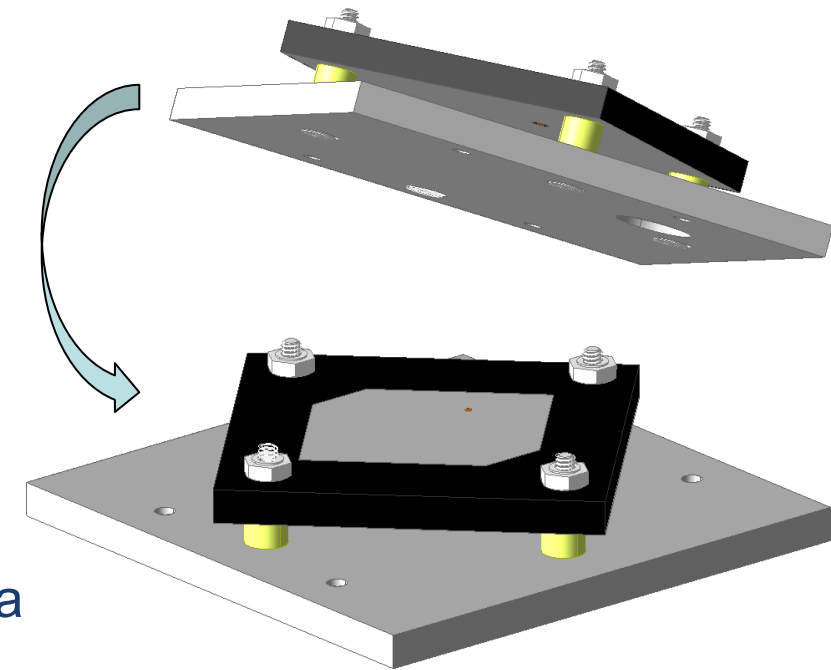
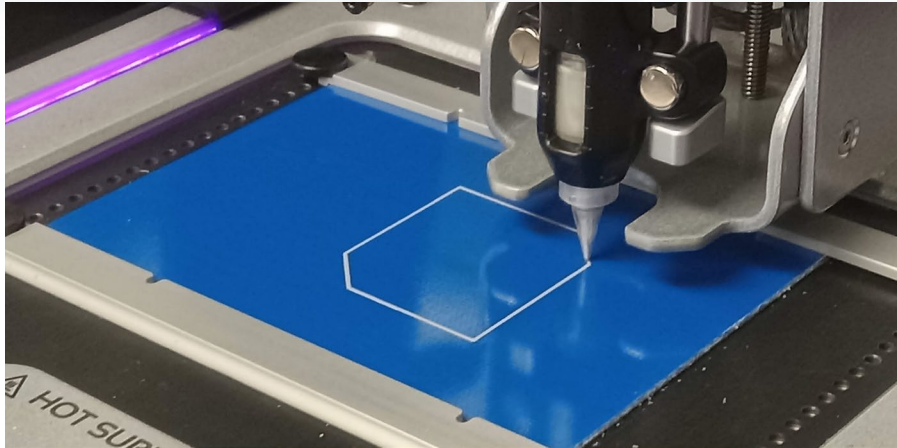

- Fly a printed TDRSS antenna, not transceiving
- Ground testing before flight
- Assessment of how printed materials hold up to elements of a balloon flight:
 - Pre- and post-flight antenna performance testing
 - Pre- and post-flight visual inspection

*Antenna design by Peter Moschetti/567

Printing by Tristan Epp Schmidt/562 Alexander Moricette/FAMU/FSU and Joshua Davey/FAMU/FSU

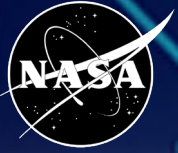

Project timeline



Time frame	Task	Location	Status
May 15	Funding approved	GSFC	-
May/June	Antenna design	Greenbelt, MD	Complete
June	Print prototypes	Greenbelt, MD	Complete
June	Adhesion testing	Greenbelt, MD	Complete
June	Drill holes in print	Greenbelt, MD	Complete
June 24	MIC/ORDM/ODR Design Review with BPO	WFF/GSFC	Complete
Early-Mid July	Iterate design and print if needed, otherwise, print extra for T-Vac and thermal tests	Greenbelt, MD	Complete
Early July	RF assembly	Greenbelt, MD	Complete
July 10	Pre-Integration Review with BPO	WFF/GSFC	Complete
Early-Mid July	Anechoic chamber testing	Greenbelt, MD	Complete
Late July	Instructions for mounting antenna plate and returning assembly	Greenbelt, MD	Complete
July 18, 19	Ground Testing	Palestine, TX	Complete
August	Integration and flight	Fort Sumner, NM	Flew Aug 22, 2024
September	Post-flight anechoic testing, inspection, data analysis	Greenbelt, MD	Late Sept – Early Oct ¹⁸

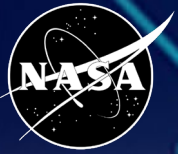

Structural Finite Element Analysis

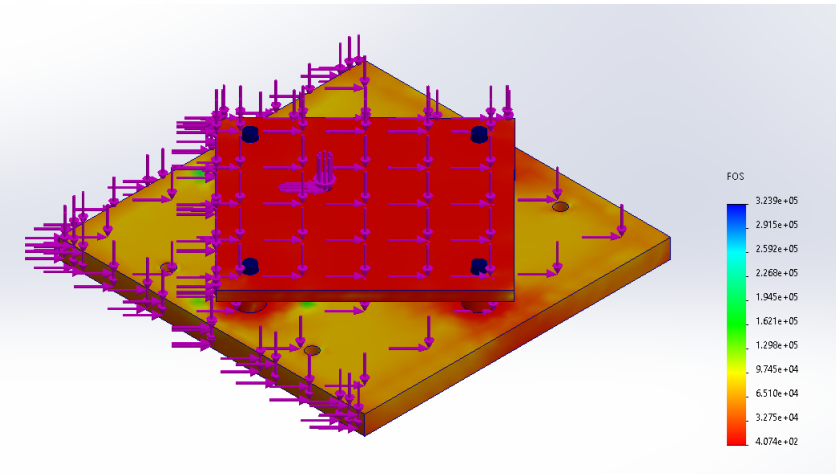
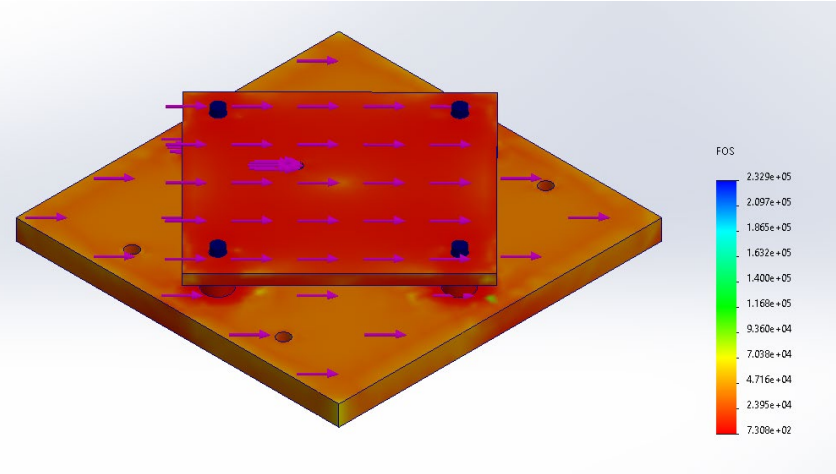
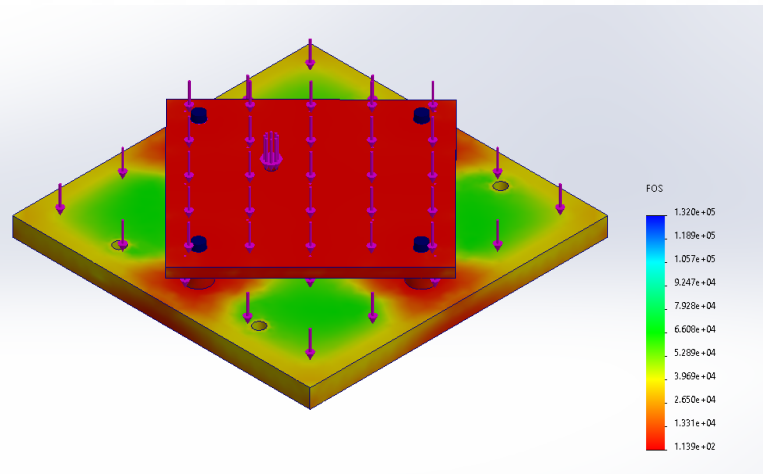

Case 1: force applied vertically downwards

- $F = 8x(\text{Weight of assembly})$
- FOS ~**110**

Case 2: force applied laterally

- $F = 4x(\text{Weight of assembly})$
- FOS ~**730**

• Case 3: force applied at a 45° angle

- $F = 4x(\text{Weight of assembly})$
- FOS ~**410**

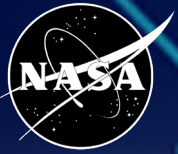

Adhesion Testing



ASTM D3359 Method B Tape Adhesion Test

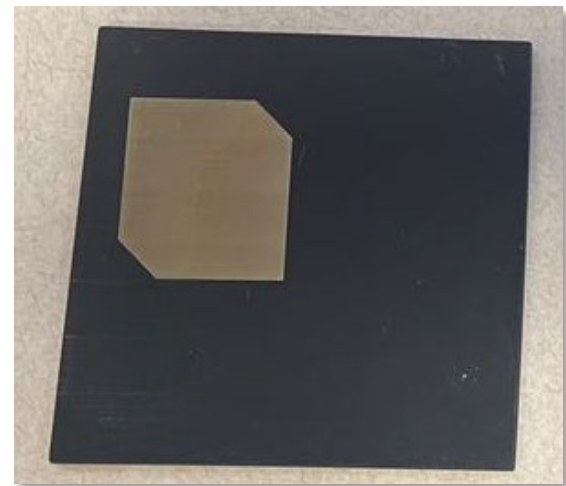

Pre-Test

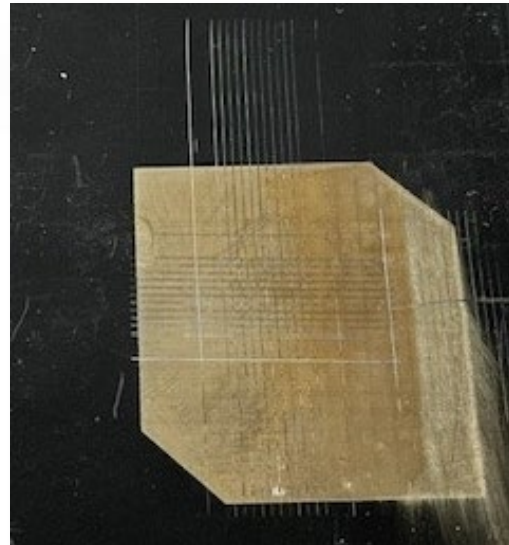

Post-Test

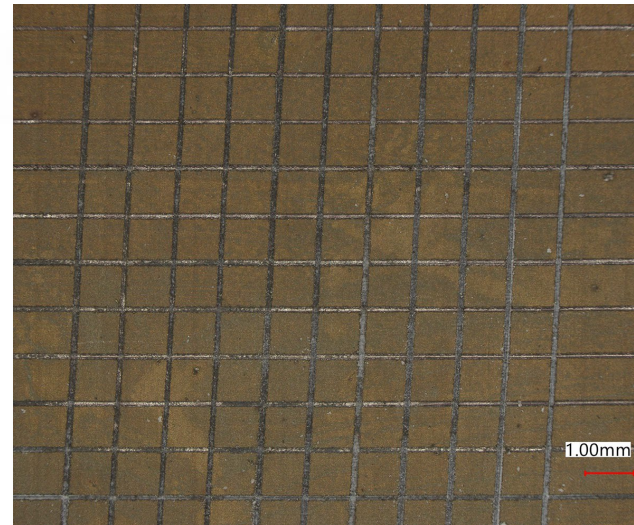

Before Tape removal



After Tape removal

Method Description: A cross hatch of 6 parallel 1mm spaced cuts are made on the coated sample in the vertical and horizontal directions. A specified tape is applied firmly to the cut area and removed rapidly (not jerked) after 90 seconds wait time. The area is inspected and graded on a 0 to 5 scale where 5 is no material removed and 0 is greater than 65% material removed.

Results: 4B, less than 5% of material removed. This represents very good adhesion of conductive ink to the Radix substrate.

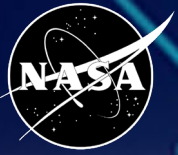

Printed magneto electric dipole design

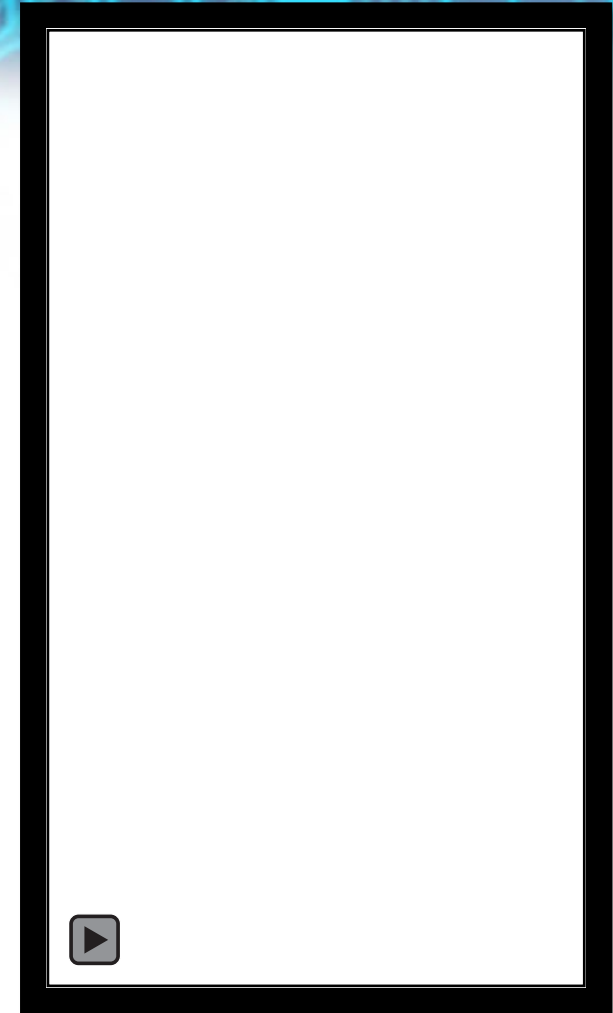
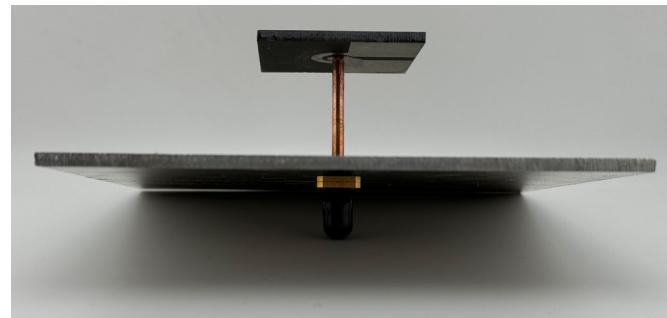
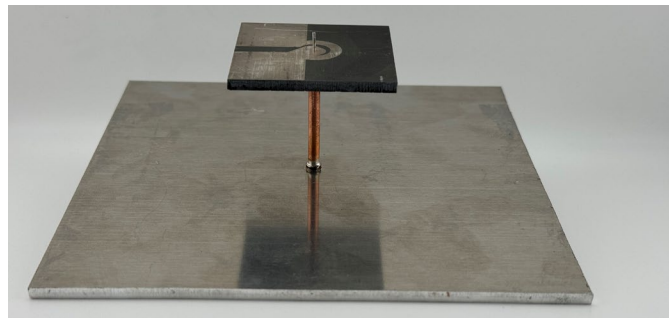
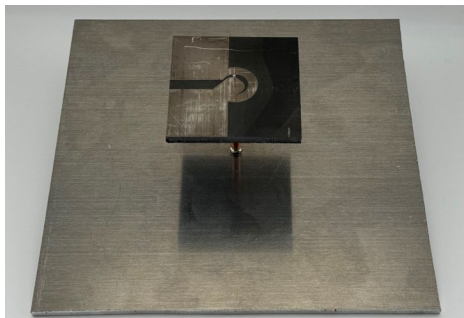
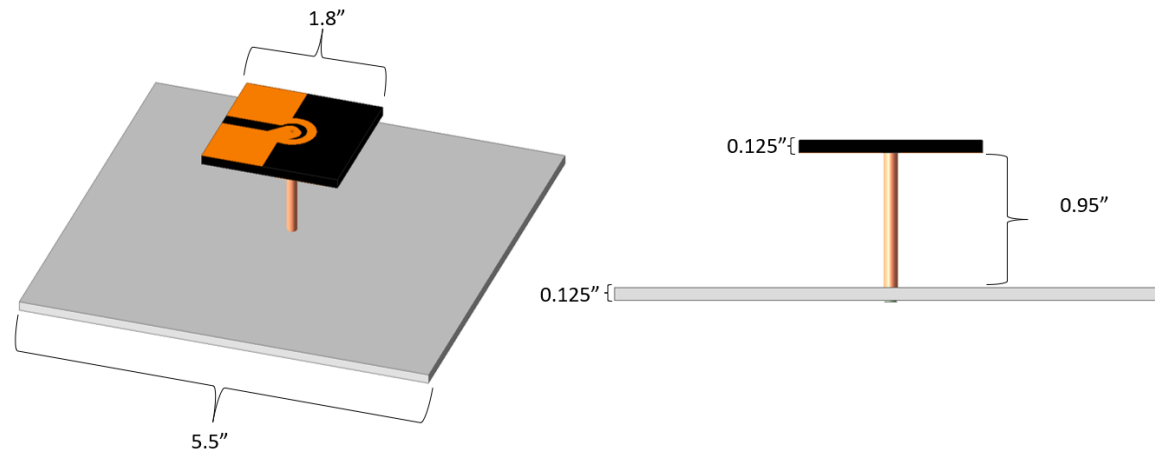

*Antenna design by Peter Moschetti/567

Printing by Tristan Epp Schmidt/562 Alexander Moricette/FAMU/FSU and Peter Moschetti/567

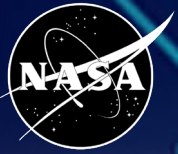

Anechoic chamber testing: Antenna signal vs. frequency

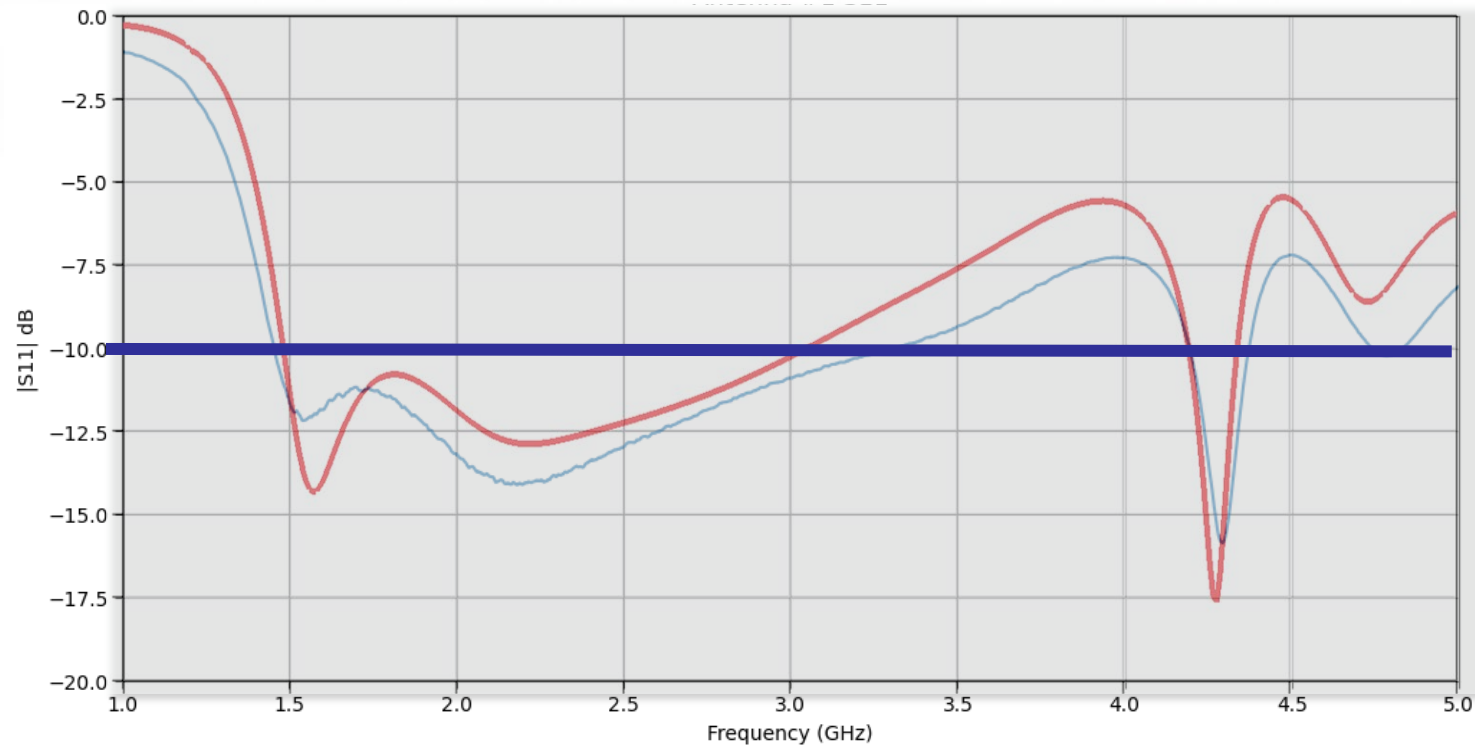

— Modeled
— Measured

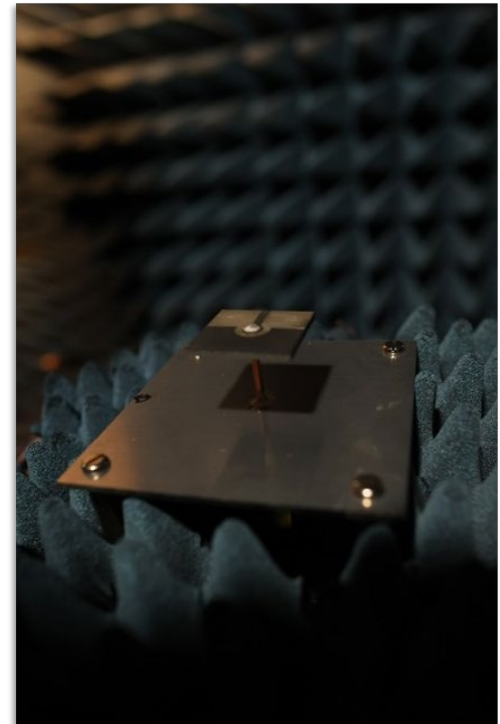

*Antenna testing performed by Justin Long/567

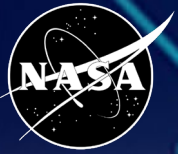

Comparing TDRSS antennas



3D Printed Magneto Electric Dipole Antenna

- Directional- Boresight
- S-Band
- LHCP
- Cost \$\$

Bifilar helix Antenna

- Omni Directional
- S-Band
- LHCP
- Cost \$\$\$\$\$

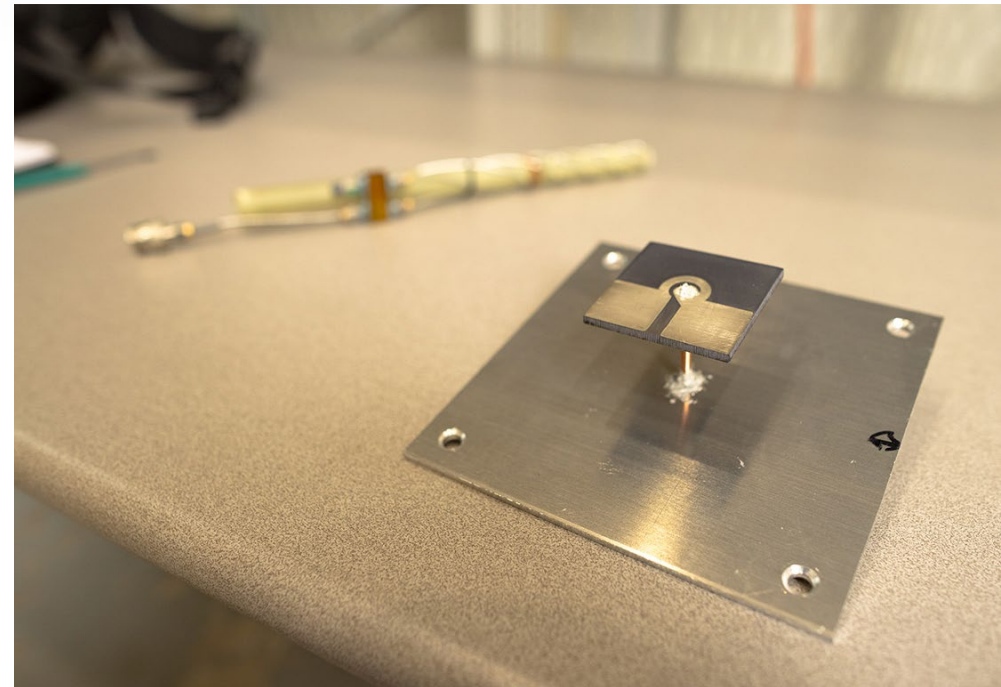

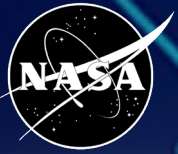

TDRSS Uplink and Downlink Testing

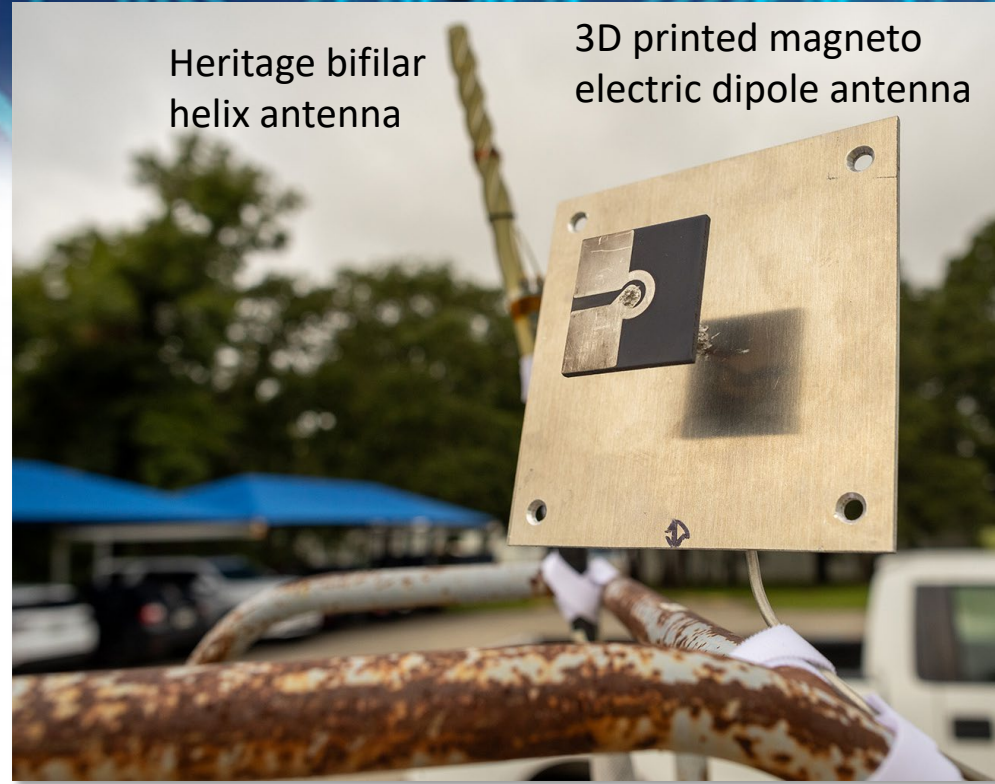

Heritage bifilar helix antenna

3D printed magneto electric dipole antenna

Testing with satellite F6

- From our location Azimuth 100° , Elevation 35°
- Data rate: 6k
- Power Out from Transceiver: 5W

[Expecting Signal Strength from 9 to 13]

Mid-latitude (nominal) [Expecting Signal Strength from 9 to 13]

- Signal Strength at F6: 13.15 - 13.33 dB

ME Dipole Transmit:

- **Vertical position:**
- Signal Strength at F6: 9.12 - 10.94 dB
- **~45° from vertical and 100° azimuth**
- Signal Strength at F6: 15.54 - 16.01 dB
- **~90° from vertical and 100° azimuth**
- Signal Strength at F6: 14.51 dB
- **~90° from vertical and 160° azimuth**
- Signal Strength at F6: 11.18 dB

Test Antenna Receive: [Expecting an AGC of <2.0]

- **Vertical position**
- AGC at Modem: 0.9-1.1
- **~45° from vertical and 100° azimuth**
- AGC at transceiver: 0.7 - 1.1
- **~90° from vertical and 160° azimuth**
- AGC at transceiver: 1.5 - 1.8

*Antenna testing performed by Peter Moschetti/567 and the Columbia Scientific Balloon Facility NASA personnel

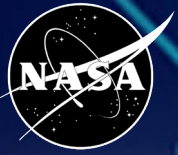

Remaining work



- Post-flight anechoic chamber testing (late September)
- Environmental testing to space specs (late September)
- Further evaluate anechoic testing data and ground testing data (October)
- Post-flight inspection of printed antenna after exposure to atmospheric conditions (October)

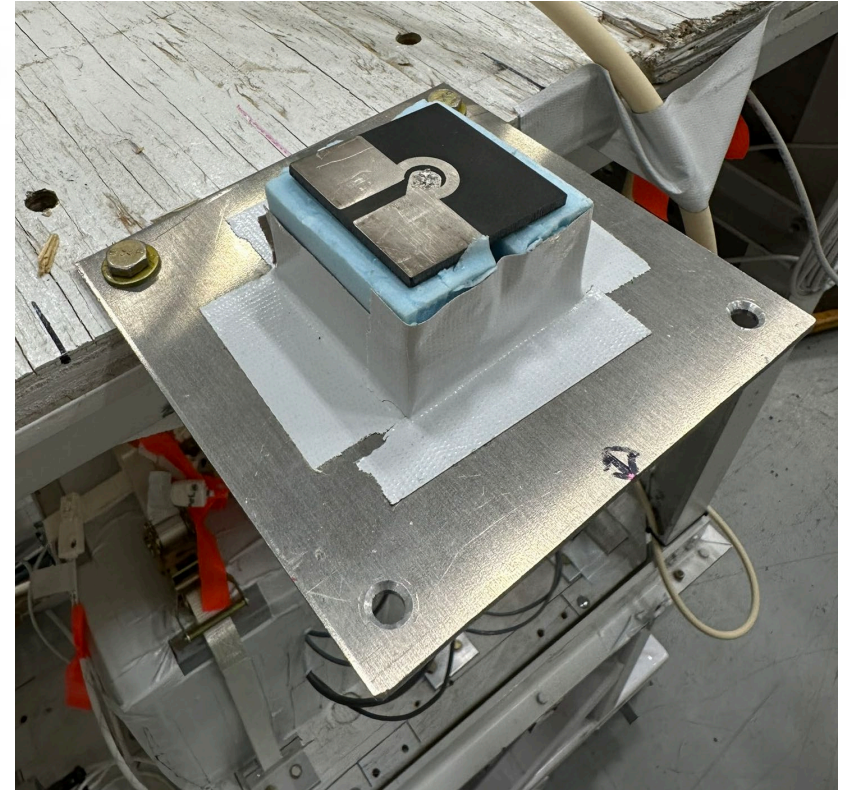

Future work for 3D Printing Electronics at NASA GSFC

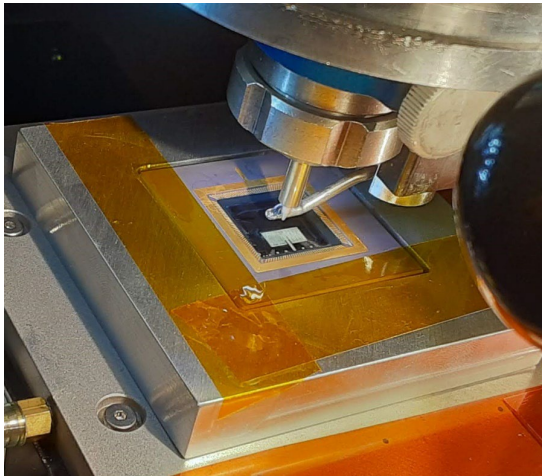
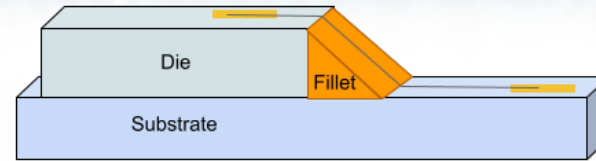

Printing antennas to
minimize losses

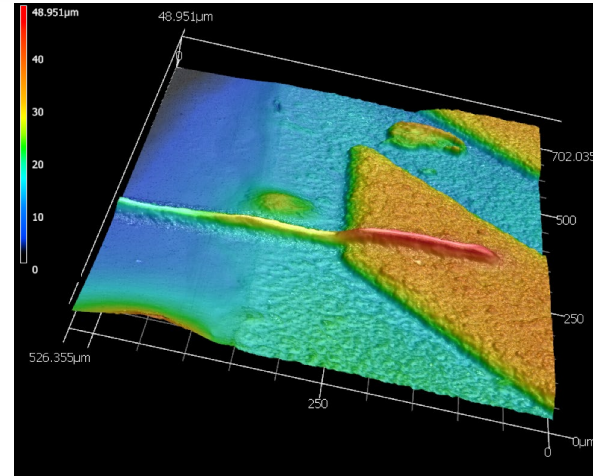

Printing interconnects and
large interconnect arrays

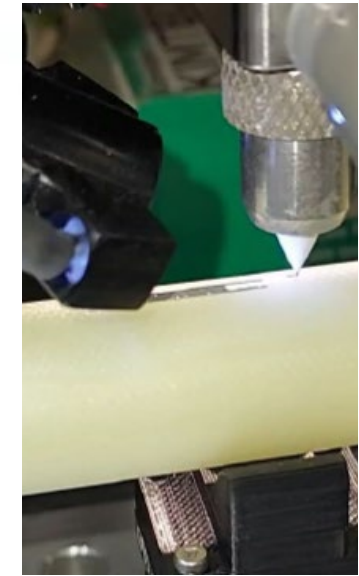

Curved surface print applications:
Antennas, strain gauges, sensors



Our partners



Aerosol Jet Printing Detector Strip Pattern on Liquid Crystal Polymer [M. Samuels/562, LPS]

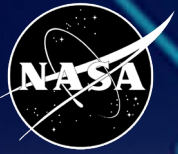

Special thanks:



- NASA GSFC 3D Printed Electronics Team:
 - Tristan Epp-Schmidt/562, Matthew Minogue/562, Beth Paquette/562, Mohammed Abdin/555
- NASA GSFC Code 567, RF branch:
 - Peter Moschetti/567, Justin Long/567
- Summer 2024 Florida A&M University interns:
 - Alexander Moricette, Joshua Davey, and Md Alamgir Hossain





Acronym Table



Acronym	Definition
ASTM	American Society for Testing and Materials
CAD	Computer aided design
CAM	Computer aided manufacturing
IRAD	Internal Research and Development
TDRSS	Tracking and Data Relay Satellite System
RF	Radio frequency
BPO	Balloon Program Office
MIC	Mission Initiation Consultation
ORDM	Operations Requirements Design Meeting
ODR	Operations Design Review
LHCP	Left hand circular polarized



Backup

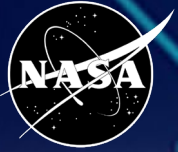

Material Profiles



- G10/FR4: Spacers
 - Elastic Modulus: $1.8616 \times 10^{10} \text{ N/m}^2$
 - Poisson's Ratio: 0.12
 - Mass Density: 1800 kg/m^3
 - Yield Strength: $2.62 \times 10^8 \text{ N/m}^2$
- Aluminum: Ground Plane
 - Elastic Modulus: $6.8 \times 10^{10} \text{ N/m}^2$
 - Poisson's Ratio: 0.36
 - Mass Density: 2699 kg/m^3
 - Yield Strength: $4 \times 10^7 \text{ N/m}^2$

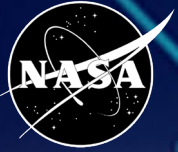

Material Profiles cont.



- PTFE: Screws and Bolts
 - Elastic Modulus: $5.64e+8$ N/m²
 - Poisson's Ratio: 0.46
 - Mass Density: 2070 kg/m³
 - Yield Strength: $2.05e+7$ N/m²
- Radix: Antenna
 - Elastic Modulus: $1.652e+9$ N/m²
 - Poisson's Ratio: 0.394
 - Mass Density: 1360 kg/m³
 - Yield Strength: $3.8e+7$ N/m²