



2024 NASA Balloon Program Overview

Scott Heatwole
NASA Balloon Program Office
Suborbital and Special Orbital Projects Directorate
Wallops Flight Facility



Strategic Objective:

Enable discovery through conduct of frequent scientific balloon flight opportunities for NASA scientific, technology development, and educational investigations.

Balloons provide low-cost, quick response, near space access for:

- Conducting cutting-edge research.
- Developing technologies to enable future spacecraft science missions.
- Advancing lighter-than-air platform technologies.
- Providing Calibration and Validation of on-orbit instrumentation.
- Enabling Hands-on Training of the next generation of scientists and engineers.

Annual Program Snapshot
8-12 Launched
3+ campaigns
300+ ugrad/grad students participate
40+ Research Institutions

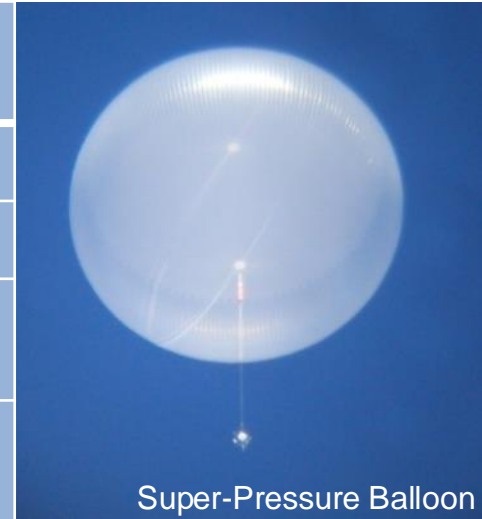

Super-Pressure Balloon



SPB SN/07



SUNRISE III



XL-Calibur/WASP



SPIDER



Worldwide Operations

Purple = Support and Operations
 Blue = Manufacturer
 Red = Annual Launch Operations
 Yellow = As Needed Launch Operations

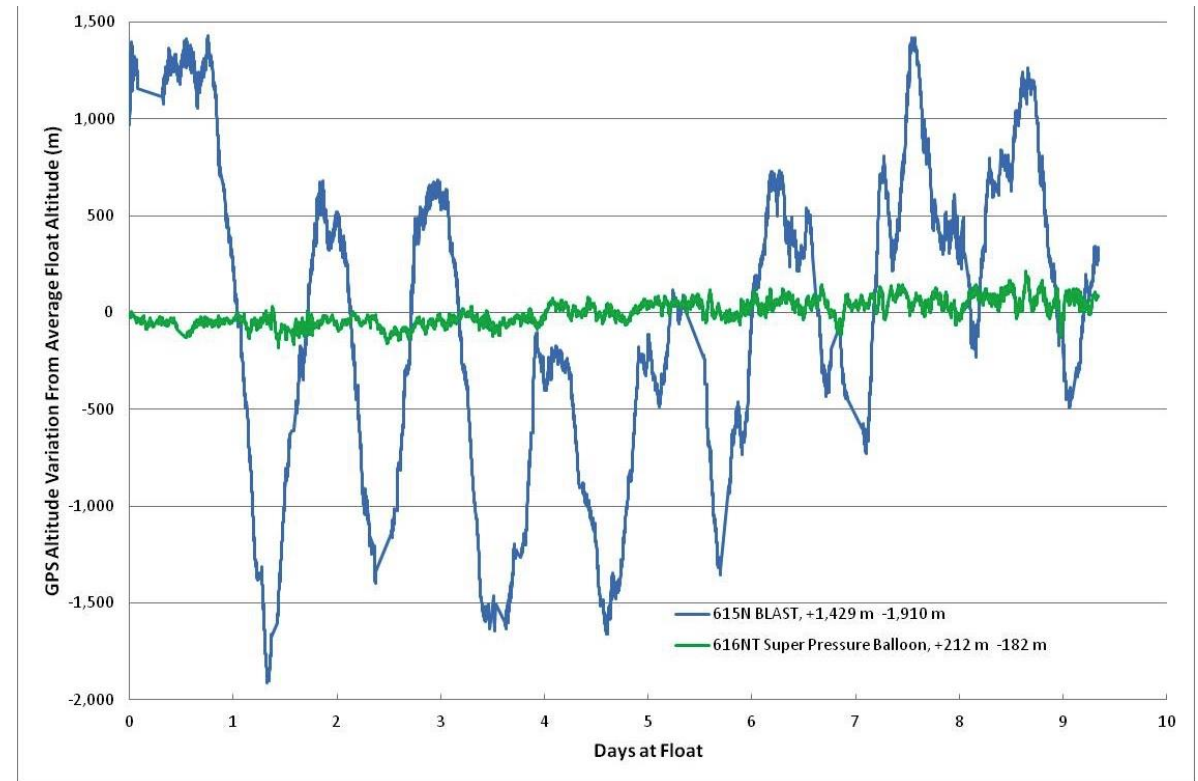

- Super Pressure Balloon provides a stable platform at mid-latitudes
- Zero Pressure Balloons are used for short duration and polar flights
 - Gas vents during the day and ballast drops are required every night to maintain altitude

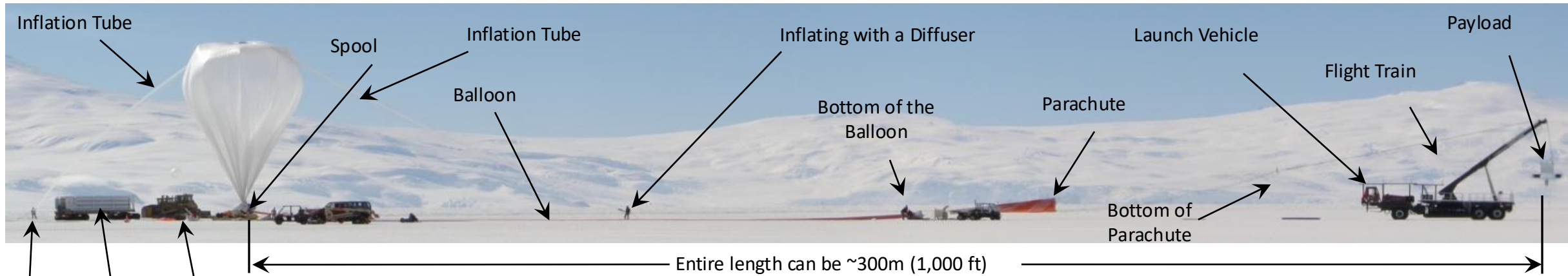

Inflating with a Diffuser

- *Before rotating into its vertical configuration for launch, the balloon system is laid out horizontally during balloon inflation.*
- *The balloon system is so large that the payload may be as far as 300 m (1,000 ft) away from the balloon!*

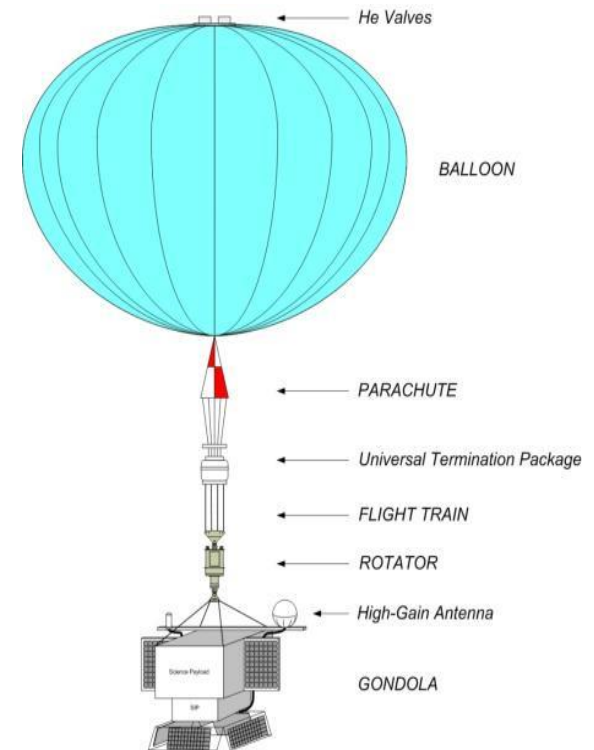

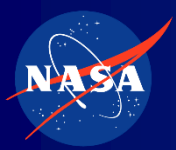

Launch Video



Goddard Space Flight Center

Wallops Flight Facility



*X-Calibur 2018 launch from
McMurdo Station*

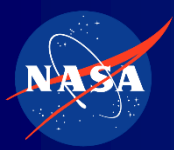

NASA Zero Pressure Standard Balloons



Goddard Space Flight Center

Wallops Flight Facility

NASA BPO provides the scientific community with suspended mass and altitudes that student balloon launches, and commercial balloon providers cannot achieve with their current infrastructure.

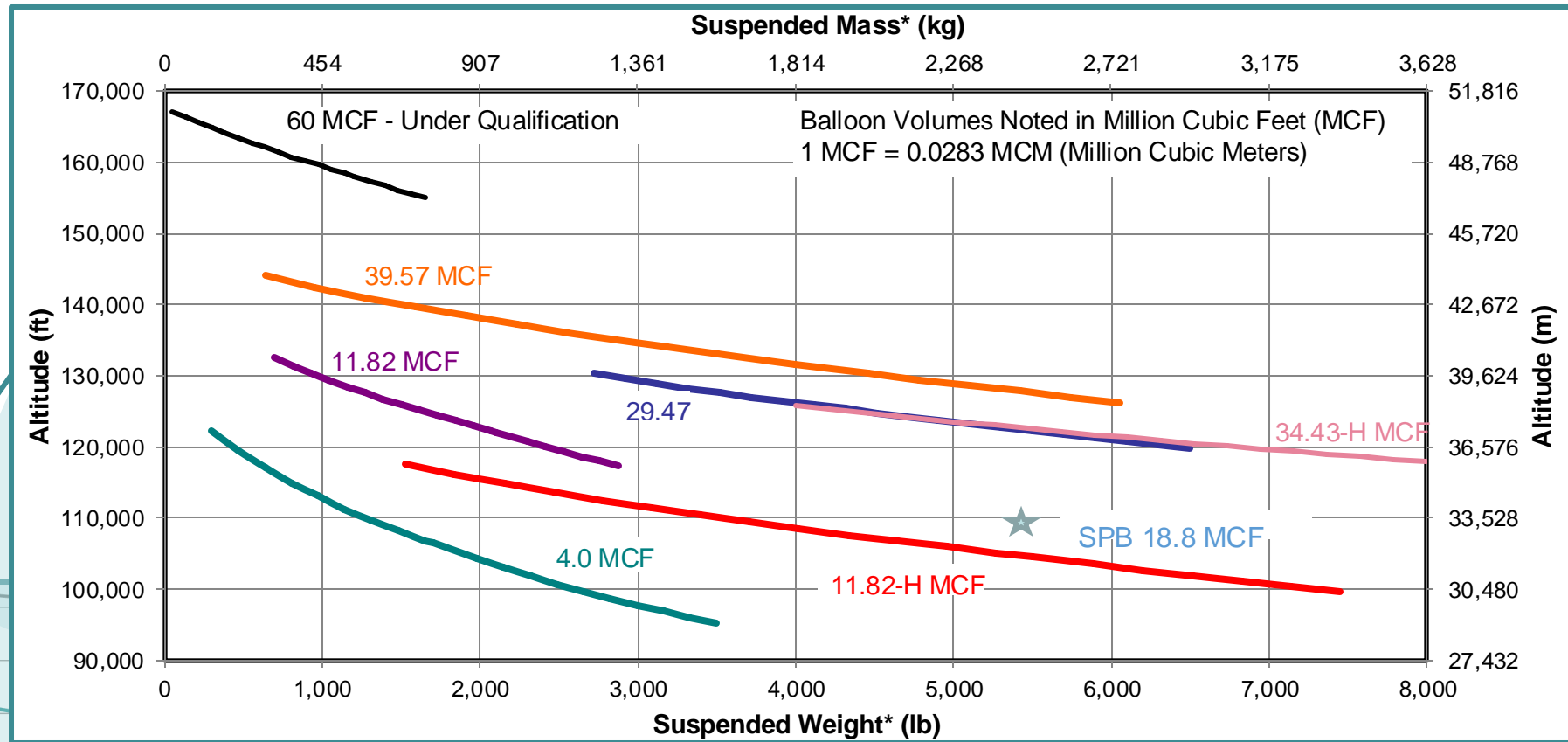
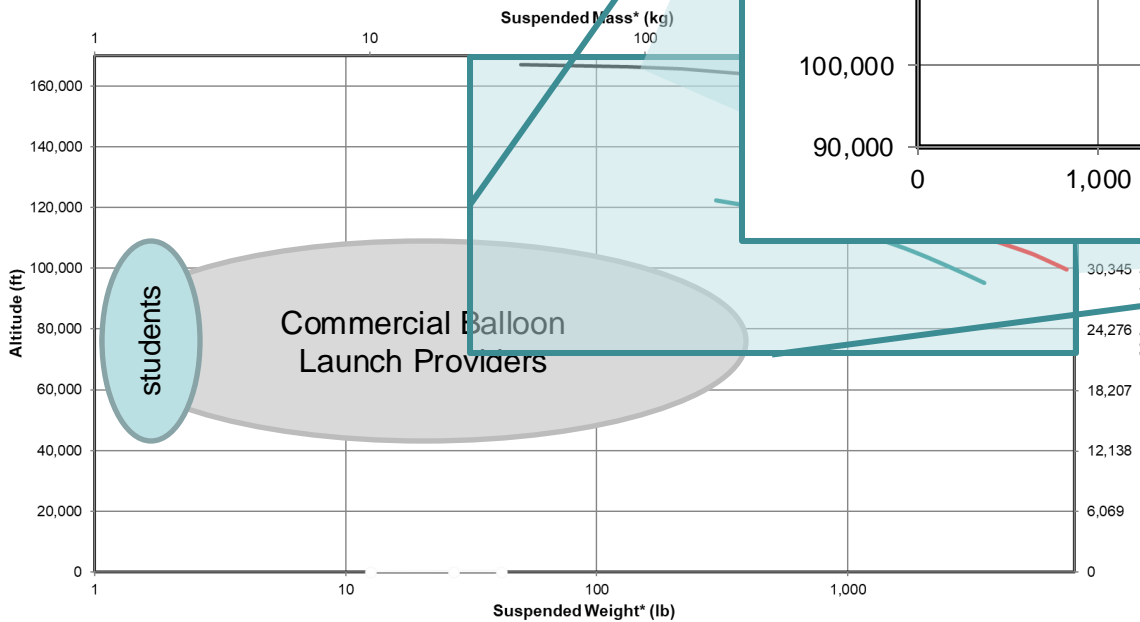

Uniquely situated for astrophysics.

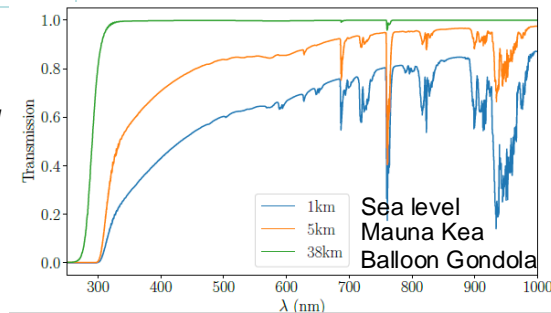

*Totals include CSBF support systems and are not science allocations.

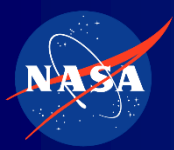

NASA Support Systems



Goddard Space Flight Center

Wallops Flight Facility

Balloon Type	Zero Pressure (ZP)	ZP	Super Pressure (SP)
Mission Type	Conventional	LDB	ULDB (In development)
Duration	2 hours to 3 days	4-6 days for Sweden 7-15 for Antarctica up to 57+ days	Up to 100 days 2016 Mid-Latitude Flight = 46 Days
Science Payload Weight	Up to 2,948 kg (Up to 6,500 lbs)	Up to 2,948 kg (Up to 6,500 lbs)	18.8 MCF* – 907 kg (2,000 lbs)
Typical Float Altitude	29.2 to 38.7 km (96 to 127 kft)	36.5 to 38.7 km (120 to 127 kft)	18.8 MCF – up to 34 km (~110 kft)
Support Package	Consolidated Instrumentation Package (CIP) <ul style="list-style-type: none"> Line of Sight (LOS) Up to 12 Mbps direct return 		Support Instrumentation Package (SIP) <ul style="list-style-type: none"> Line of Sight (LOS) - Up to 12 Mbps direct return Over The Horizon (OTH) 6 kbps / 92 kbps TDRSS Downlink** 80 kbps Iridium option***
	Small Launch Package <ul style="list-style-type: none"> Stand alone package for small payload support LOS and OTH TM & Command (Iridium) 255 byte/min packets Up to 12 Mbps LOS option System without batteries ~20 lbs (9 kg) 		
<p>* MCF – Million Cubic Feet **300kbps/1Mbps in development ***Iridium – limited support</p>			

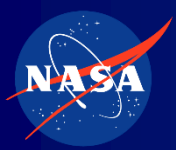

FY23 Flight Manifest



Goddard Space Flight Center

Wallops Flight Facility

Mission	Discipline	Oct	Nov	Dec	Jan	Feb	Mar	Apr	May	Jun	Jul	Aug	Sep
McMurdo Station, Antarctica													
<i>Austral Summer '22</i>													
Fillippini / UI / SPIDER	IR, Submillimeter, Radio			♦									
Roth / WFF / 60 MCF Qualification Flight IV • Clem / UD / AESOP [Payload of Opportunity]	Qualification Flight			Cancelled by NSF									
Roth / WFF / 60 MCF Qualification Flight V • Sample / MSU / BOOMS [Piggyback]	Qualification Flight			Cancelled by NSF									
Salter / CSBF / LAURA • Bowman / NSL / ANIHALA [Piggyback]	Qualification Flight			Cancelled by BPO									
Wanaka, New Zealand													
<i>Austral Fall '23</i>													
Fairbrother / WFF / SPB SN08 • Jones / PU / SuperBIT [Payload of Opportunity]	Qualification Flight							♦					
Fairbrother / WFF / SPB SN09 • Olinto / UC / EUSO [Payload of Opportunity]	Qualification Flight								♦ Failure				
Palestine, Texas													
<i>Summer '23</i>													
Tang / JPL / WHATSUP [Hand Launch]	Solar System										♦		
Fries / JSC / CDCP (ETF) [Hand Launch]	Solar System									Cancelled by PI			
Fort Sumner, New Mexico													
<i>Fall '23</i>													
McConnell / UNH / GRAPE	Gamma Ray												♦
Salter / CSBF / CSBF Test Flight Salter	Test Flight											♦	♦
Granger / LSU / HASP	Student Outreach												♦
Martin / CalTech / FIREBall-II (T)	UV and Visible											Science Failure ♦	
Kleinboehl / JPL / JPL-Remote (T)	Earth Science												♦
Nagler / GSFC / EXCITE (T)	IR, Submillimeter, Radio											Delayed to FY24	
Wender / LANL / TinMan [Hand Launch]	Gamma Ray											Delayed to FY24	

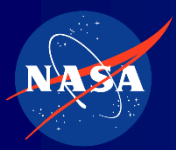

FY24 Flight Manifest



Goddard Space Flight Center

Wallops Flight Facility

Mission	Discipline	Oct	Nov	Dec	Jan	Feb	Mar	Apr	May	Jun	Jul	Aug	Sep
McMurdo Station, Antarctica		Austral Summer '23											
Roth / WFF / 60 MCF Qualification Flight IV • Clem / UD / AESOP-Lite [PO]	Qualification Flight				◆								
Walker / UA / GUSTO	Astro - IR, Submm, Radio				◆								
Salter / CSBF / LAURA	Qualification Flight			◆									
Esrang, Sweden		Spring '24											
Roth / WFF / 60 MCF Qualification Flight V • Sample / MSU / BOOMS [PO]	Helio - Geospace Sciences										◆		
Krawczynski / WUSTL / XL-Caliber	Astro - High Energy										◆		
Wakely / UC / HELIX	Astro - Cosmic Ray / Particle								◆				
Solanki / MPS / SUNRISE 3	Helio - Solar and Heliospheric										◆		
Palestine, Texas		Summer '24											
Fries / JSC / CDCP [Hand Launch]	Solar System											Delayed to FY25 by PI	
Fort Sumner, New Mexico		Fall '24											
Salter / CSBF / CSBF Test Flight Salter	Test Flight												◆
Wender / LANL / TinMan [Hand Launch]	Astro – High Energy											◆	
Granger / LSU / HASP	Student Outreach												◆
Granger / LSU / HASP 2	Student Outreach												◆
Krawczynski / UWSL / DR-TES	Astro – High Energy												◆
Nagler / GSFC / EXCITE [ETF] (T)	Astro - IR, Submm, Radio											◆	
Vieira / UoI / TIM [ETF] (T)	Astro - IR, Submm, Radio												◆
Young / SWRI / THAI-SPICE (T)	Astro - UV and Visible											Delayed to FY25 by PI	
Switzer / GSFC / EXCLAIM [ETF] (T)	Astro – IR, Submm, Radio											Delayed to FY25 by PI	
Martin / CalTech / FIREBall-II (T)	Astro – UV and Visible											Delayed to FY25 by PI	
Boeing / UCLA / MATTADOR-TF	Earth Sci – Upper Atmos											Delayed to FY25 by PI	
Samra / SAO / WASP CORSAIR [ETF]	Helio – Solar and Heliospheric											Delayed to FY25 by PI	

Acronyms:
 ETF Engineering Test Flight
 T Turnaround Mission



McMurdo Station, Antarctica



Goddard Space Flight Center

Wallops Flight Facility

Flight Season	Dec – Jan
Lat/Long*	77.8500° S, 166.6667° E
Trajectory	West
Float Speed	5 – 30 kts (9 – 55 kph)
Science Mass	6000 lbs (2722 kg)

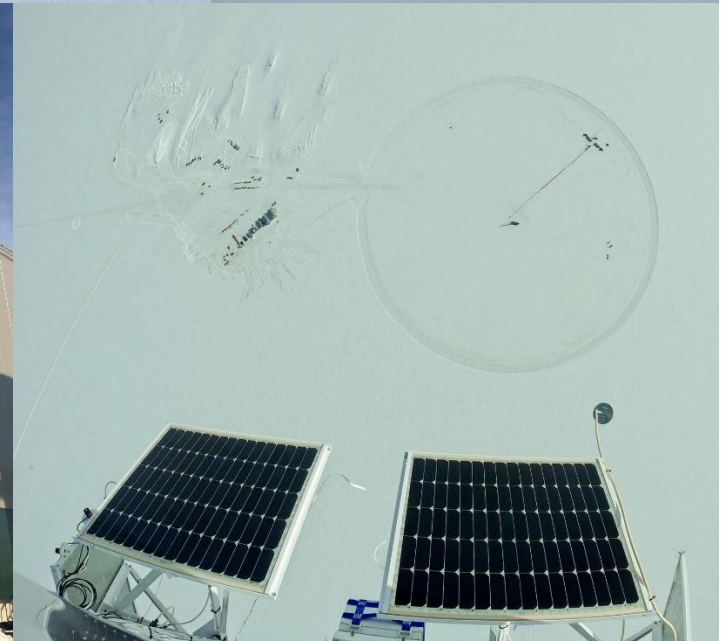



Flight Season

April – Aug

Lat/Long*

44.7222° S, 169.2455° E

Trajectory

East

Float Speed

10 – 120 kts (18 – 222 kph)

Science Mass

3000 lbs (1361 kg)

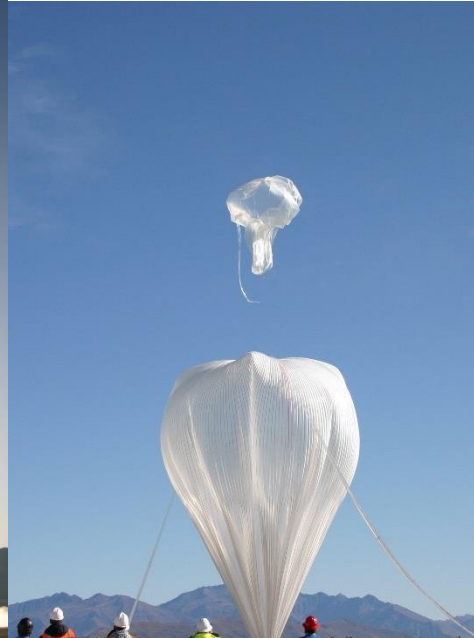

Flight Season	May - July
Lat/Long*	67.8833° N, 21.1167° E
Trajectory	West
Float Speed	10 – 30 kts (18 – 55 kph)
Science Mass	6000 lbs (2722 kg)





Flight Season

Aug - Oct

Lat/Long*

34.4731° N, 104.2422° W

Trajectory

West / East

Float Speed

10 – 70 kts (18 – 129 kph)

Science Mass

6000 lbs (2722 kg)



Palestine, Texas

Flight Season	May - Jul
Lat/Long*	31.7786° N, 95.7144° W
Trajectory	West
Float Speed	20 – 70 kts (37 - 130 kph)
Science Mass	2000 lbs (907 kg)

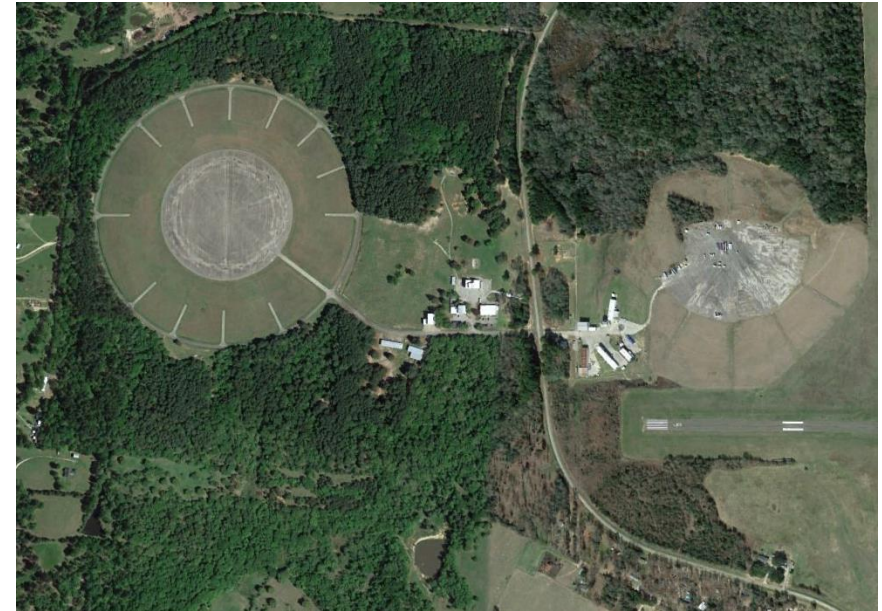

Alice Springs, Australia

Flight Season	Mar - May
Lat/Long*	23.80° S, 133.89° E
Trajectory	Turnaround
Float Speed	0 – 70 kts (0 – 130 kph)
Science Mass	6000 lbs (2722 kg)

NASA will require a new domestic U.S. launch site in the future that will better accommodate NASA Safety requirements for standard balloon operations and test flights as well as increase the number of missions per year that can fly through the night.

Draft Schedule:

- FY24:
 - Planning
- FY25:
 - Phase I, Start build up to support hand launch.
 - Phase II, Start construction mods (if applicable) to support Small balloon launch.
 - Note, phases may be started/executed in parallel.
- FY26:
 - Phase III, Start construction to support Large balloon launch.
- FY27:
 - Complete Phase III. Burns launch site, ready to support any/all launches.

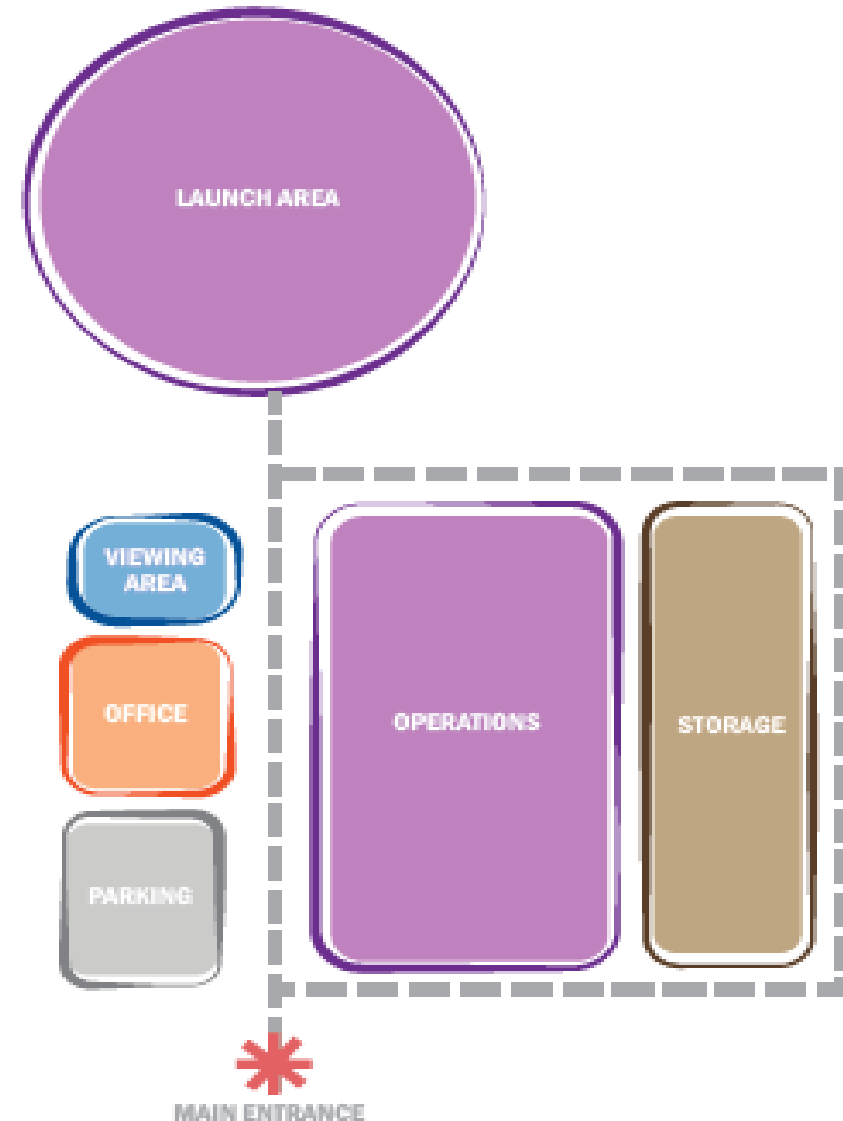

- Wide-field, sub-arcsecond resolution imager for the SPB platform
- Demonstrate SPB capable sub-arcsecond pointing platform
- Provide a lensing data for a comprehensive catalog of galaxy clusters
- SuperBIT micro-capsule (< 1 kg) 'drop' packages proposed as overflight of land masses occur
- SpaceKiwi
- Launched April 15, 2023 – 39 day flight circling globe 5.5 times

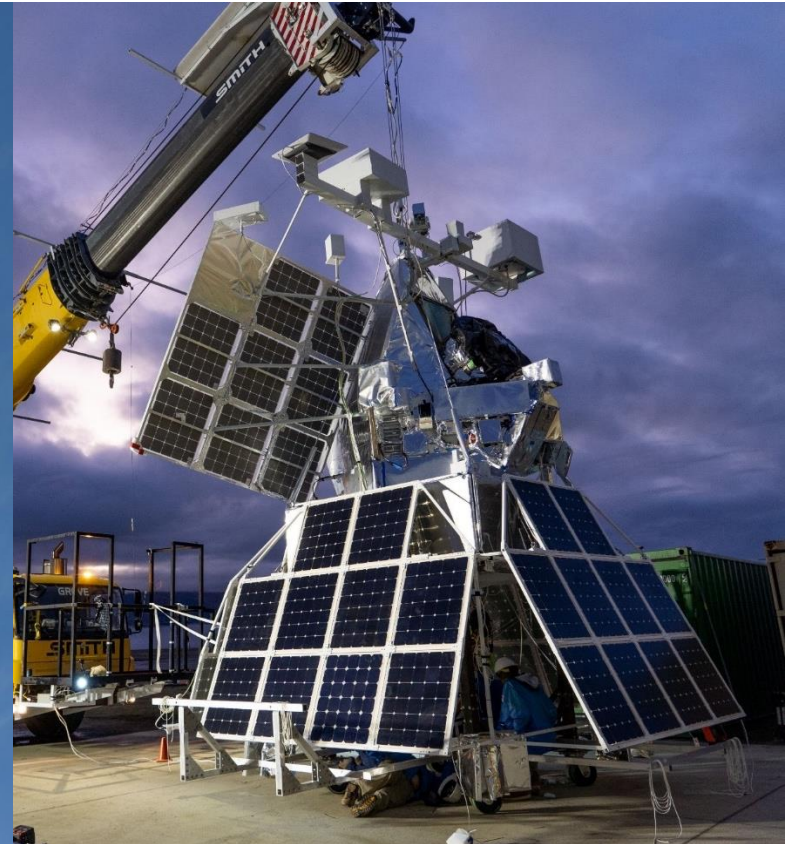

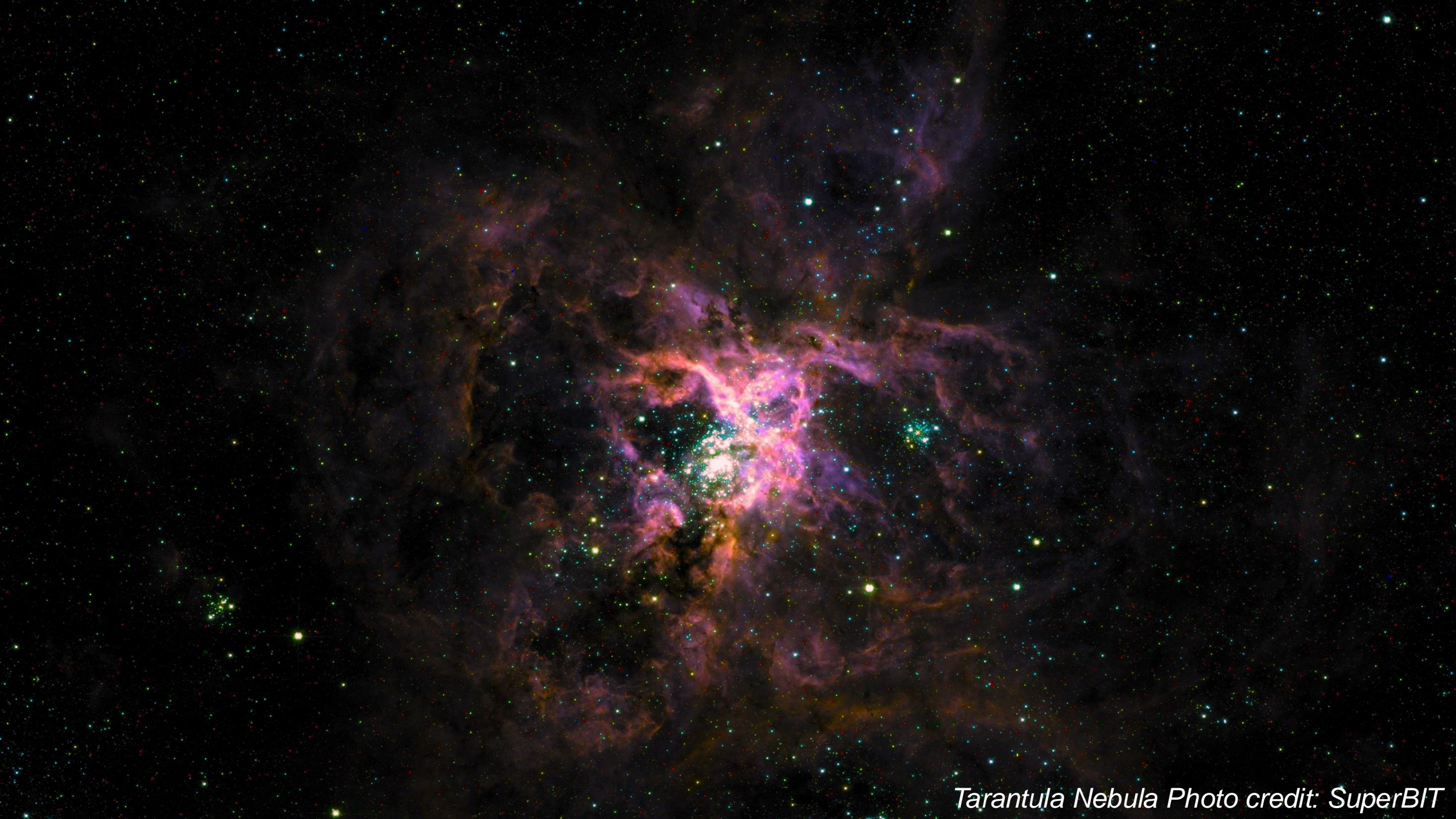

Tarantula Nebula Photo credit: SuperBIT

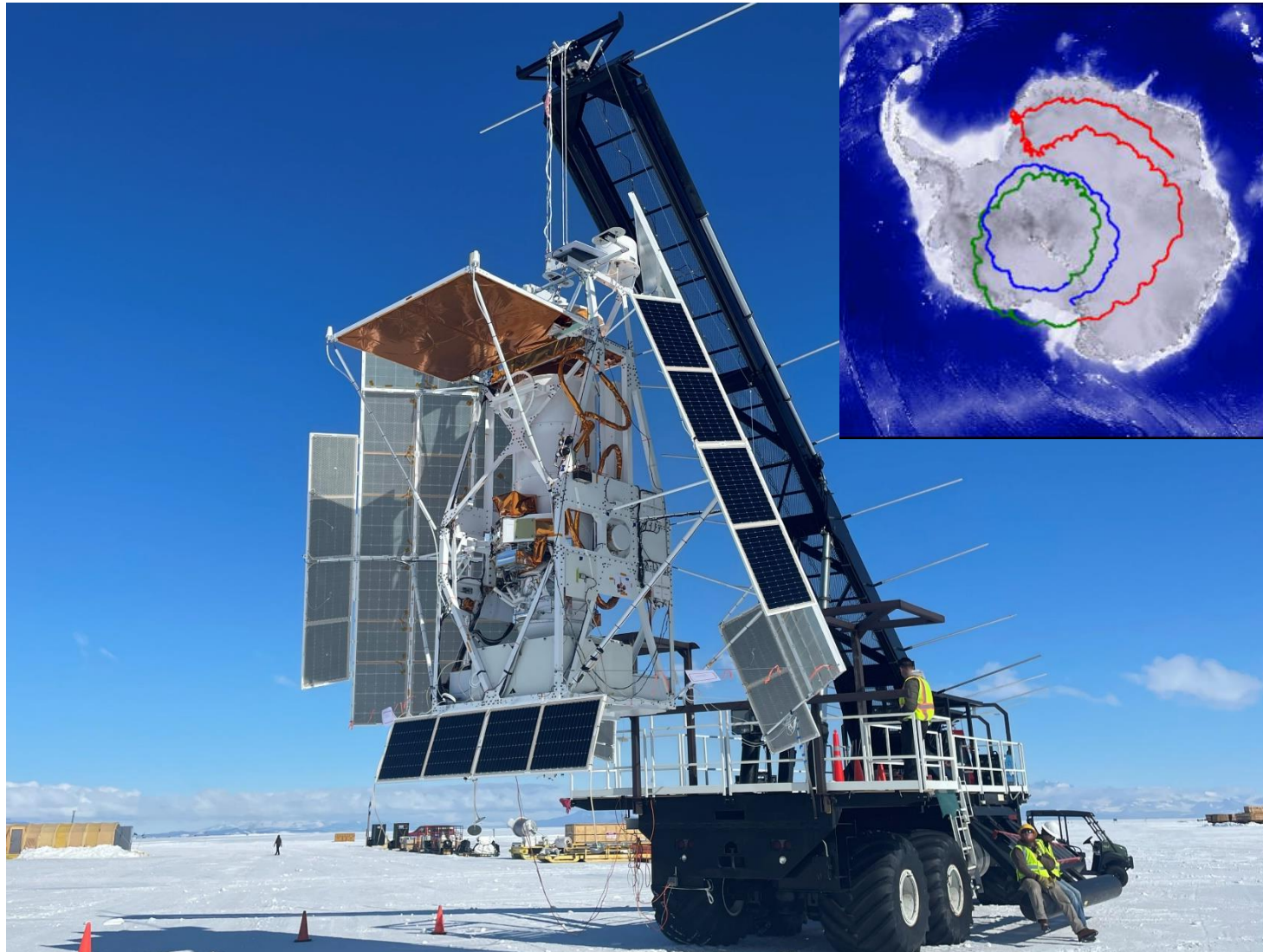

- LDB Mission
- The Galactic/Extra-Galactic ULDB Spectroscopic Terahertz Observatory (GUSTO) is an Explorer Mission of Opportunity project to develop and fly a balloon borne Terahertz observatory to conduct a spectroscopic survey of the Milky Way (MW) and Large Magellanic Cloud (LMC) to determine the composition of the Interstellar Medium (ISM).
- Set the new record for NASA heavy-lift, long-duration balloon at over 57 days a lot.
- Total Flight Time: 57 days, 17 hours, 20 mins

- LDB Mission
- HELIX (High Energy Light Isotope eXperiment) is a magnet spectrometer designed to measure high-energy cosmic-ray isotopes to understand the propagation history of cosmic rays by making precision measurements of certain key light isotope ratios at high energy.
- Launched from Esrange, Sweden
- Landed in Ellesmere Island, Canada
- Total Flight Time: 6 days, 8 hours, 27 mins



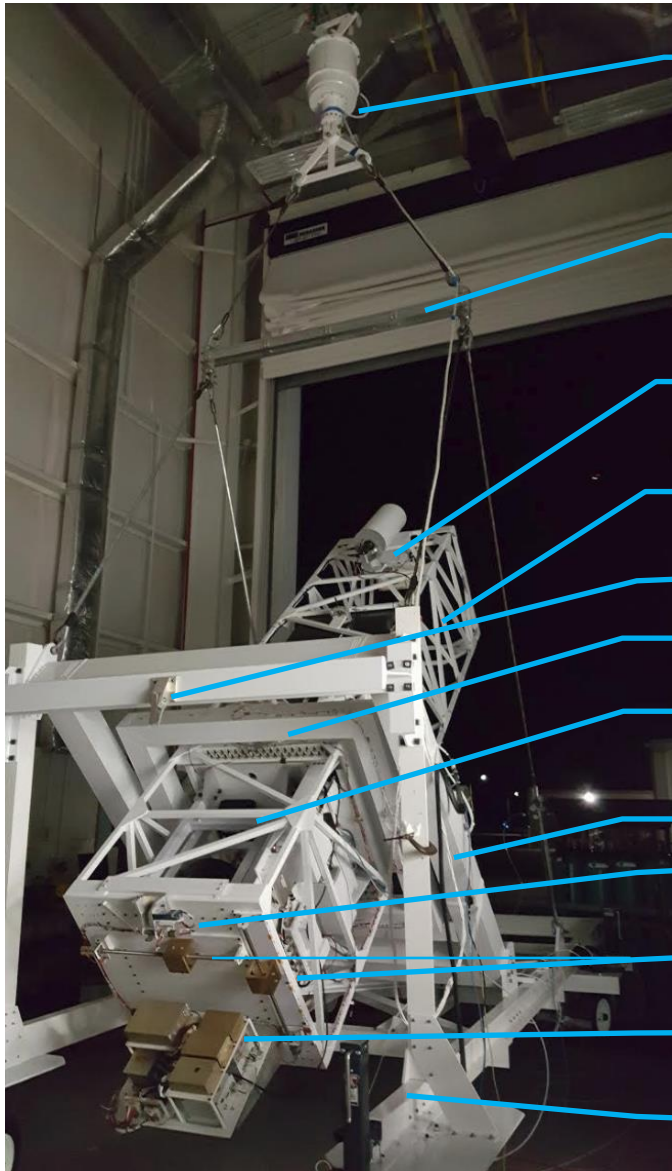

- Rotator
- Suspension Bridle
- Star Tracker
- Instrument Support Structure
- Caging Mechanism (passive half)
- Inner Gimbal Frame
- Inertial Measurement Unit
- Outer Gimbal Frame
- Caging Mechanism (active half)
- Flight Adjustable Trim Weights
- WASP Flight Electronics
- Main gondola structure

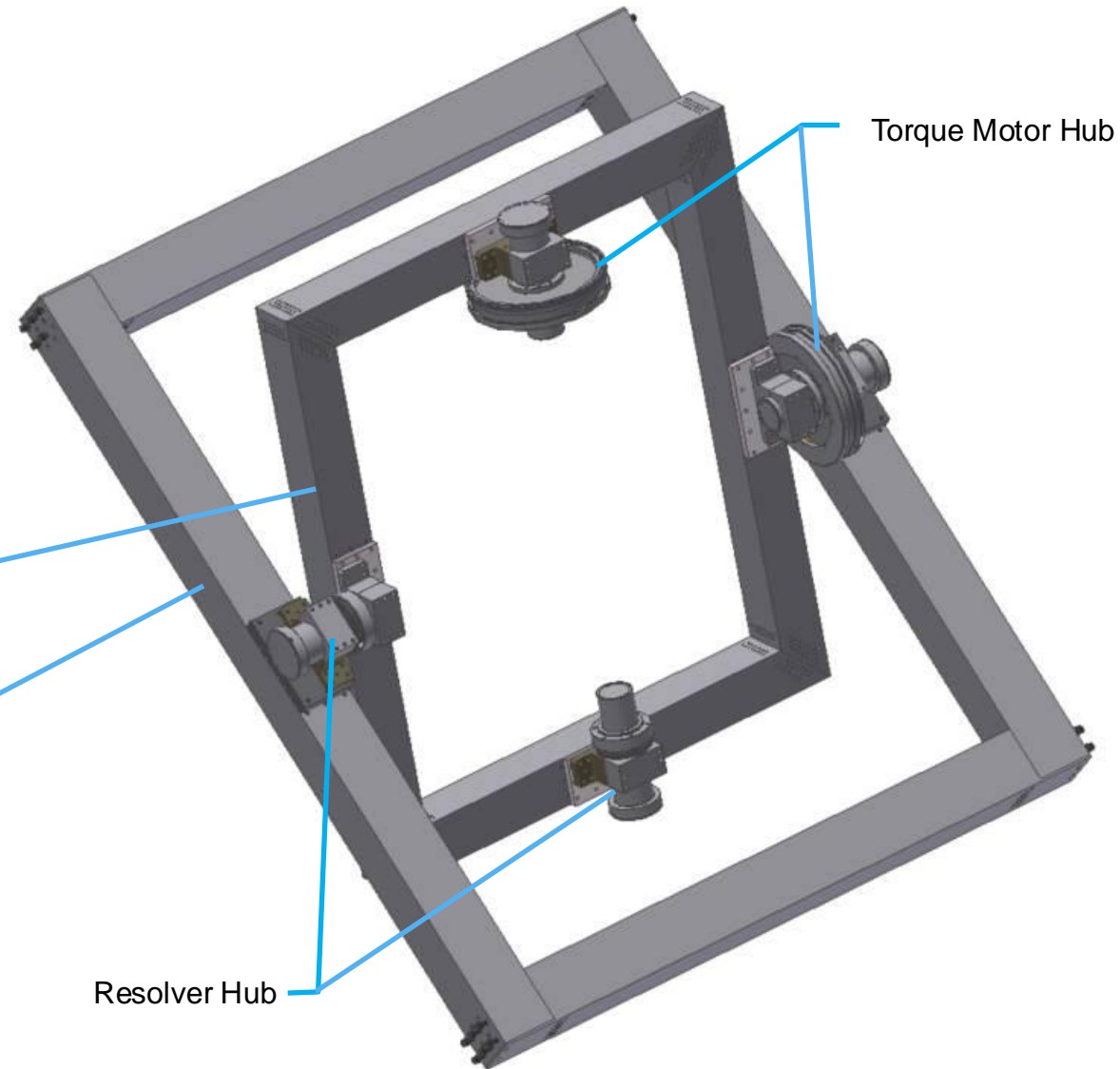

- Picture-C incorporated a coronagraph with a deformable mirror.
- With their instrument on the WASP platform, it was able to achieve milli-arc second accuracy.
- WASP point summary
 - Science target count: 7
 - Time on target: 7 hours, 29 mins
 - Pitch RMS: 0.1 – 0.2 arcsec
 - Yaw RMS: 0.2 – 0.4 arcsec
- Total flight time: 19 hours, 16 mins



- XL-Calibur incorporated an X-Ray telescope along a 12 m truss.
- 2022
 - Launch from Esrange, Sweden
 - Landed in Yellowknife, Canada
 - Total flight time: 6 days, 7 hrs, 49 mins
- 2024
 - Launch from Esrange, Sweden
 - Landed in Kugluktuk, Canada
 - Total flight time: 4 days, 16 hrs, 51 mins



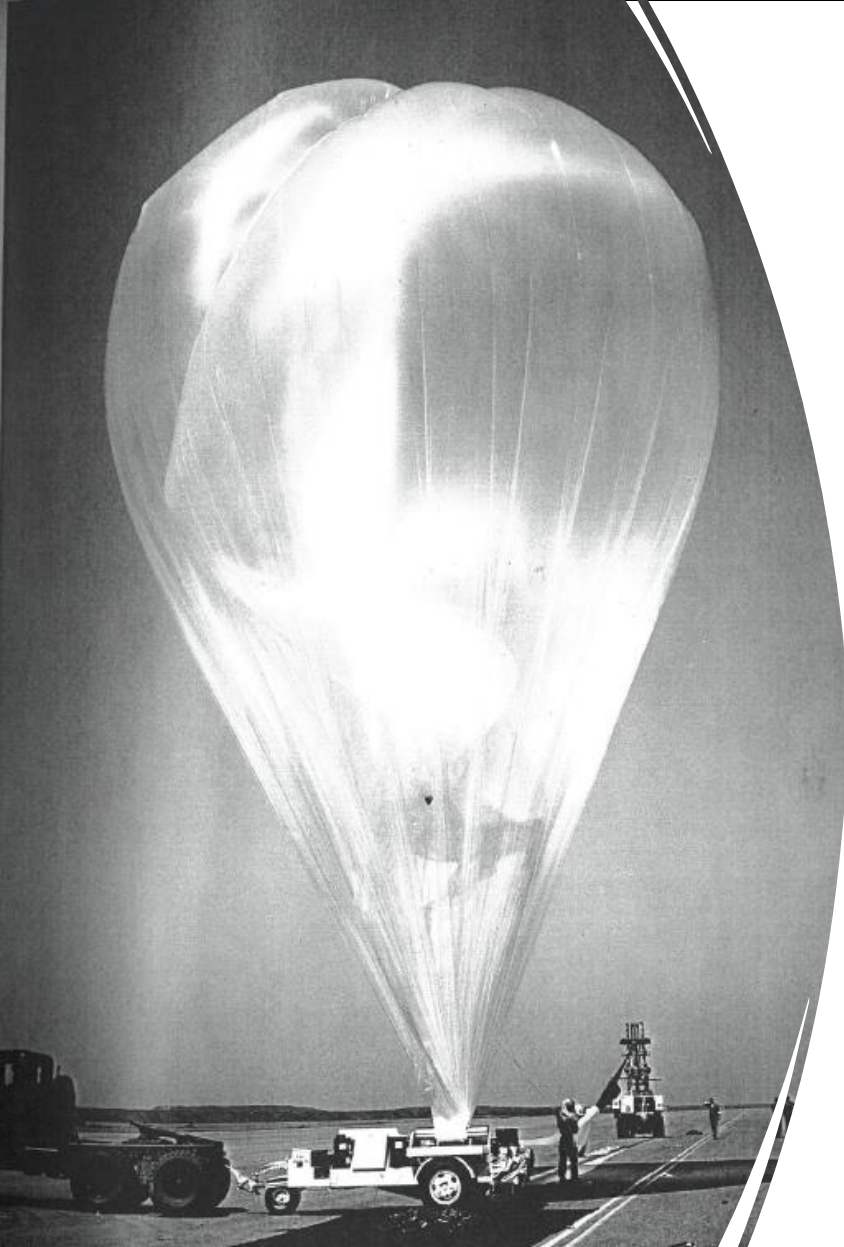

- Literature Review - Since introduction of plastic balloons:
 - Over 300 identified flights using hydrogen
 - 97% made of polyethylene (same material as BPO balloons)
 - Flights from 7 countries with 5 organizations
 - NSBF/CSBF last identified balloon launch using hydrogen was in 1980
- 23/24 – Allocated funding to develop framework
 - CSBF Hydrogen investigation
 - Safety considerations
 - Operational shifts and risks
 - Public perception

- Current
 - Line of Sight Telemetry
 - 15.6Mhz bandwidth digital transmission (EVTM)
 - Over the Horizon
 - Iridium Global Services
 - TDRSS Services
- Looking Forward
 - SpaceX Starlink
 - Flown on SPB Missions SN08-SuperBIT, on SN09-EUSO II, and GUSTO
 - Requires nominal 75-90W during flight, at startup and during firmware updates power demand can increase to 200W
 - Speeds seen 4Mbps – 30Mbps to ground
 - Free Space Optical Communications (FSOC)
 - The BPO is committed to demonstrating this technology from our platform.
 - Working within NASA, other government agencies, and commercial partners.
 - IRAD funding award allowing for purchase of interface equipment and working towards collaborations with interested partners.
 - Optical communications systems are high cost but have extremely high data capabilities (Gbps+).

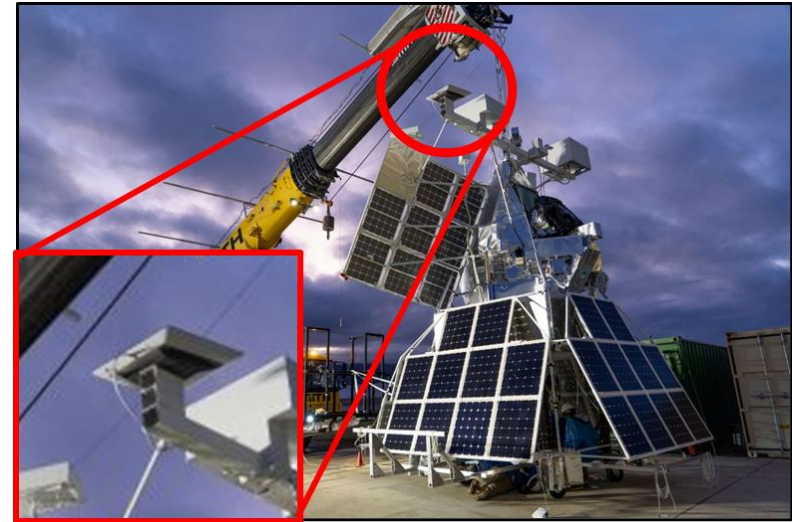

- The NASA Balloon Program provides low-cost stable platforms in the stratosphere for NASA science and technology.
- Balloons provide an excellent training ground for scientists and engineers.
- Mission Operations, Technology, Education and Public Outreach, and the Columbia Scientific Balloon Facility discussed in more detail in the following presentations.

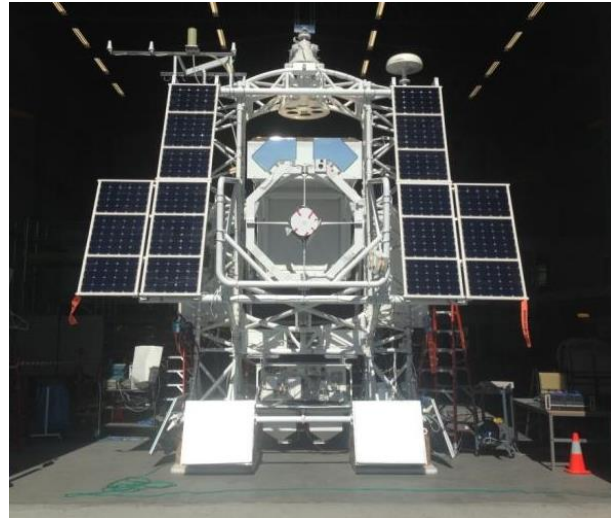
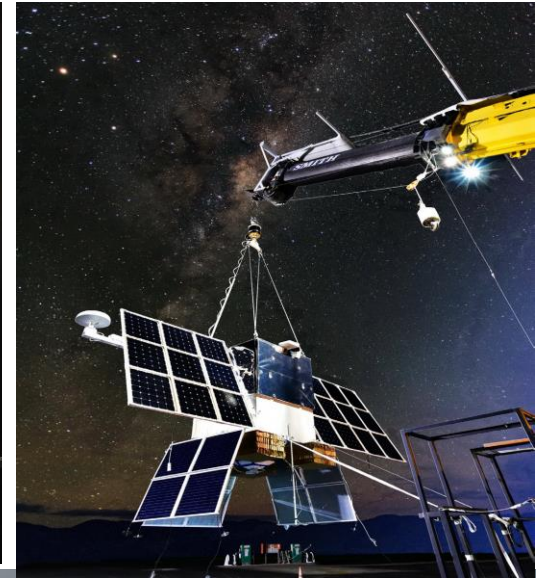
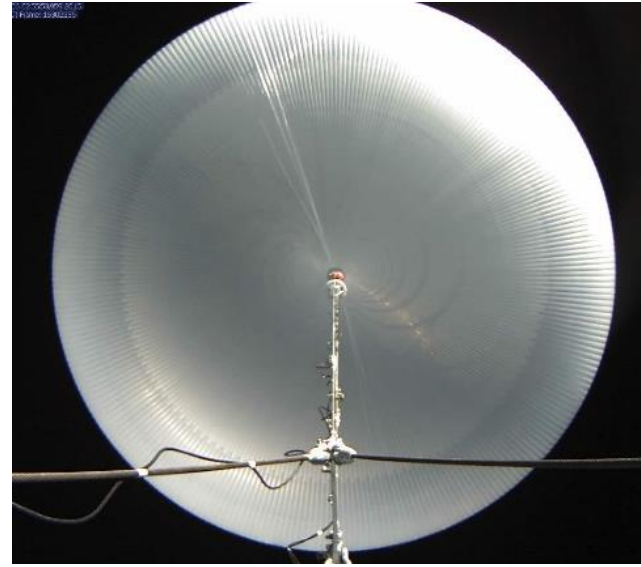

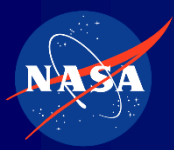

Acknowledgements



The activities reported today would not have been possible without the dedication and support from NASA, NSF, the Balloon Program Office, the CSBF, Raven Aerostar, the science community, and our support contractors!