

Calorimeter Heat Flux Trends in NASA's Subscale Rotating Detonation Rocket Engine

Joseph Hernandez-McCloskey, Seth A. Reutlinger, Daniel I. Pineda

The University of Texas at San Antonio (UTSA), San Antonio, Texas

Thomas W. Teasley, Dillon M. Petty

NASA Marshall Space Flight Center (MSFC), Huntsville, Alabama

AIAA SciTech Forum

Orlando, Florida, United States

January 09, 2025

UTSA Engineering

Acknowledgements

- NASA Space Technology Mission Directorate (STMD)
 - Early Career Initiative Program
 - New Technology Demonstration Program
- NSTGRO Fellowship (NASA Space Technology Graduate Research Opportunity), grant no. 80NSSC22K1215
- NASA MSFC ET10 testing team, the Dannys, and east test area weld shop for preparation of hardware
- Ari Goldman and Michaela Hemming for additional data collection activities during test campaign

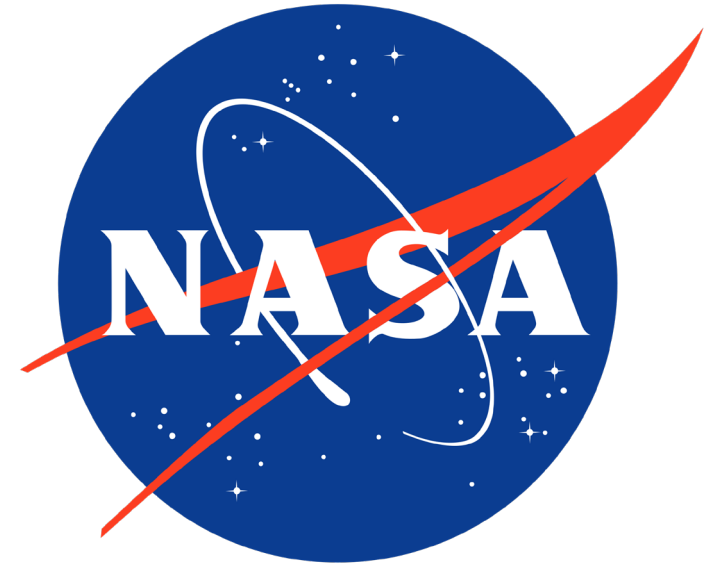

- **Background/Motivation**
 - Rotating detonation rocket engine (RDRE) heat transfer
- **Design**
 - Calorimeter hardware design
 - Experimental setup
- **Heat Flux Trends**
- **Data Transformation**
 - Calorimeter Transfer Function (CTF)
- **Computational Analysis**
 - Conjugate heat transfer (CHT), boiling
- **Future Work**

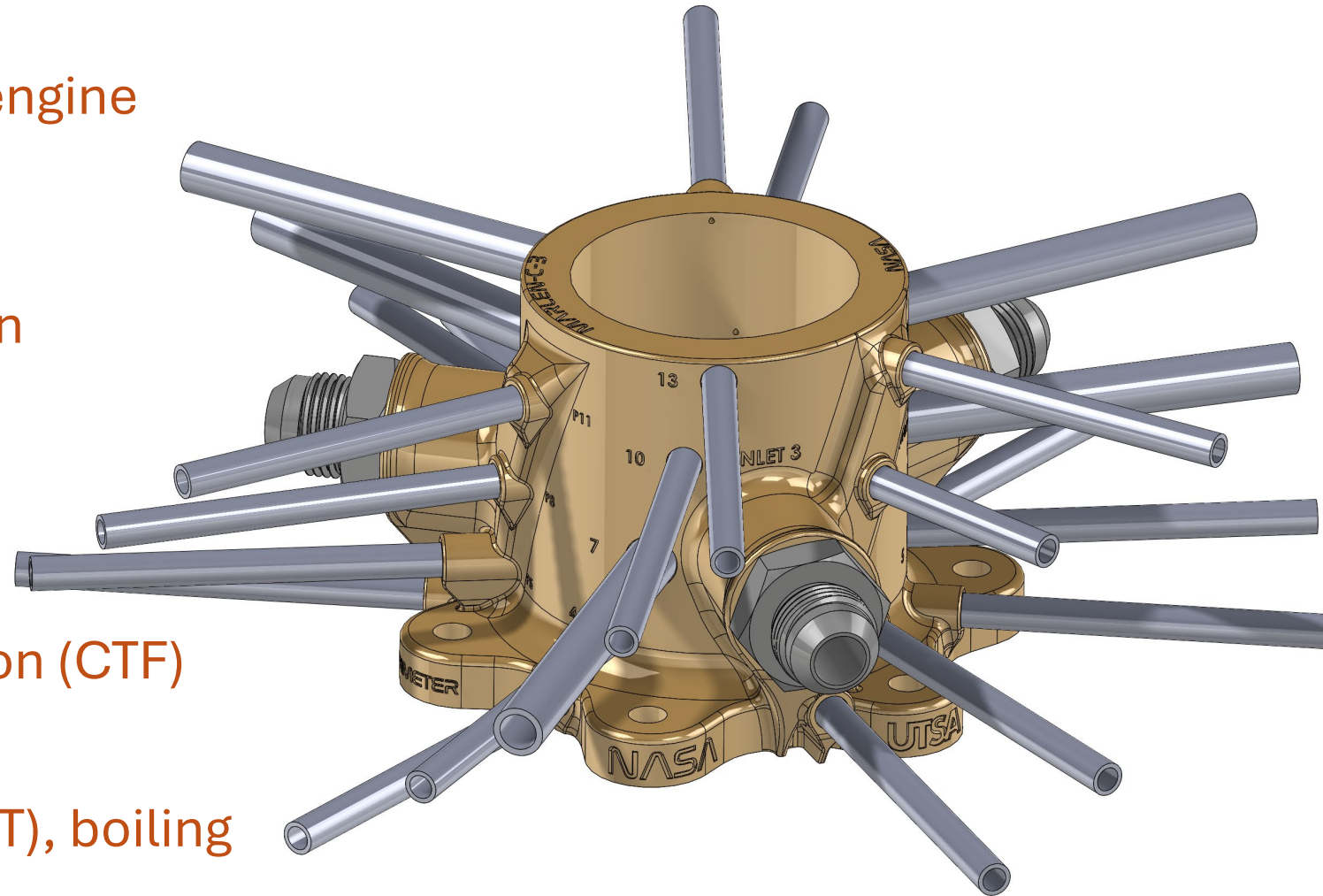

Background

- Detonation-based combustion
 - Benefit space mission architectures
 - Lower entropy (s) → same work for smaller combustor size vs. deflagration

Low Technology Readiness Level (TRL)

- Detonation heat transfer
 - Higher temperature (T)
 - Periodic heating in RDRE walls
 - Varies with configuration and operational setpoint
 - No known heat transfer (HT) correlations (e.g., Bartz)

Cannot calculate HT → remain low-TRL

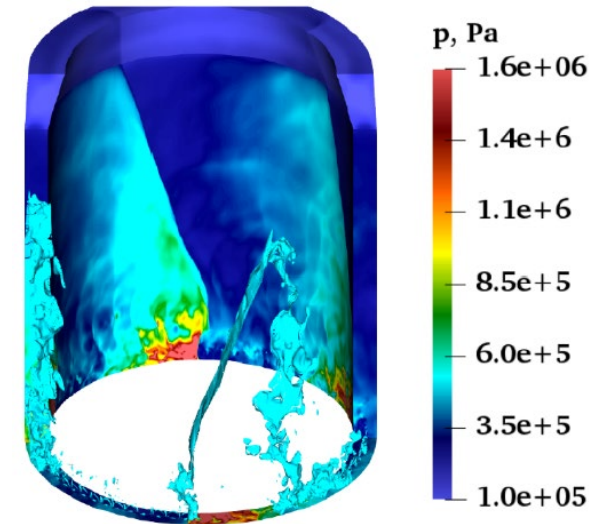
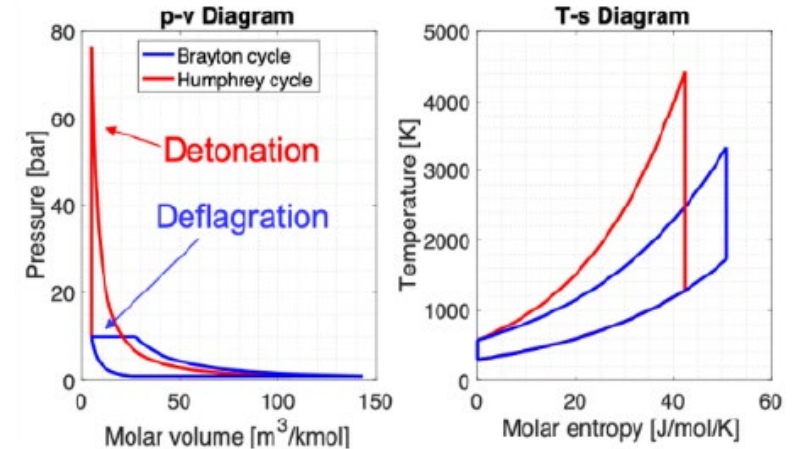

Demystify RDE/RDRE Heat Transfer

- Canonical msmt: conduction
- Limited test time (<1000 ms)
- Limited spatial resolution

→ No steady-state trends

- Excellent spatial resolution
- Limited test time (<1000 ms)
- Requires calibration

→ No steady-state trends

- Excellent test time (∞)
- Limited spatial resolution
- Real estate for sensors

→ Limited local trends

Heat Sink
(heavy copper)



Optical
(glass or plastic chamber)

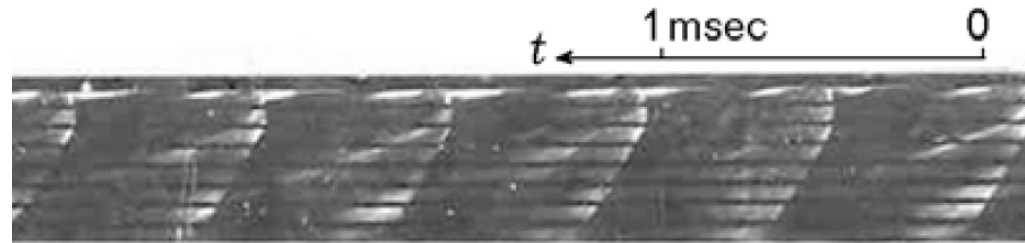

Bykovskii et al. (2009)

Axial Channel
(actively-cooled, bulk inlet/outlet)

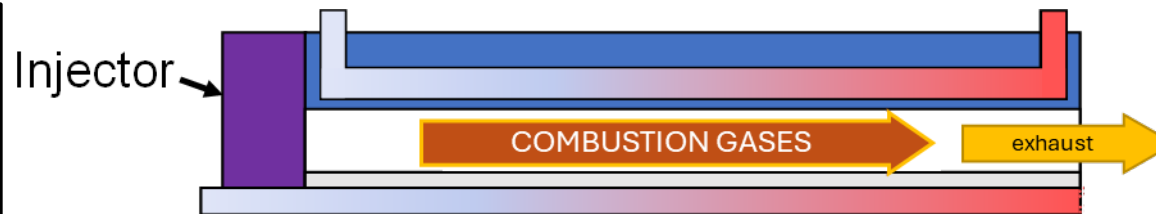

To advance TRL, require steady-state (SS) local heat flux trends

Calorimeter Design

- Circumferential channels
 - Enthalpy difference

$$q'' = \frac{\dot{Q}}{A} \quad \dot{Q} = \dot{m}\Delta h \approx \dot{m}\bar{c}_p(T_{\text{out}} - T_{\text{in}})$$

Local heat flux (q'')

- 3 in. length
- **13 heat flux stations**
 - 8 single-channel
 - 5 double-channel
 - 3 manifolds/6 channels
- **9 chamber pressure**
 - Capillary tube attenuated pressure (CTAP)

Steady-state cooling

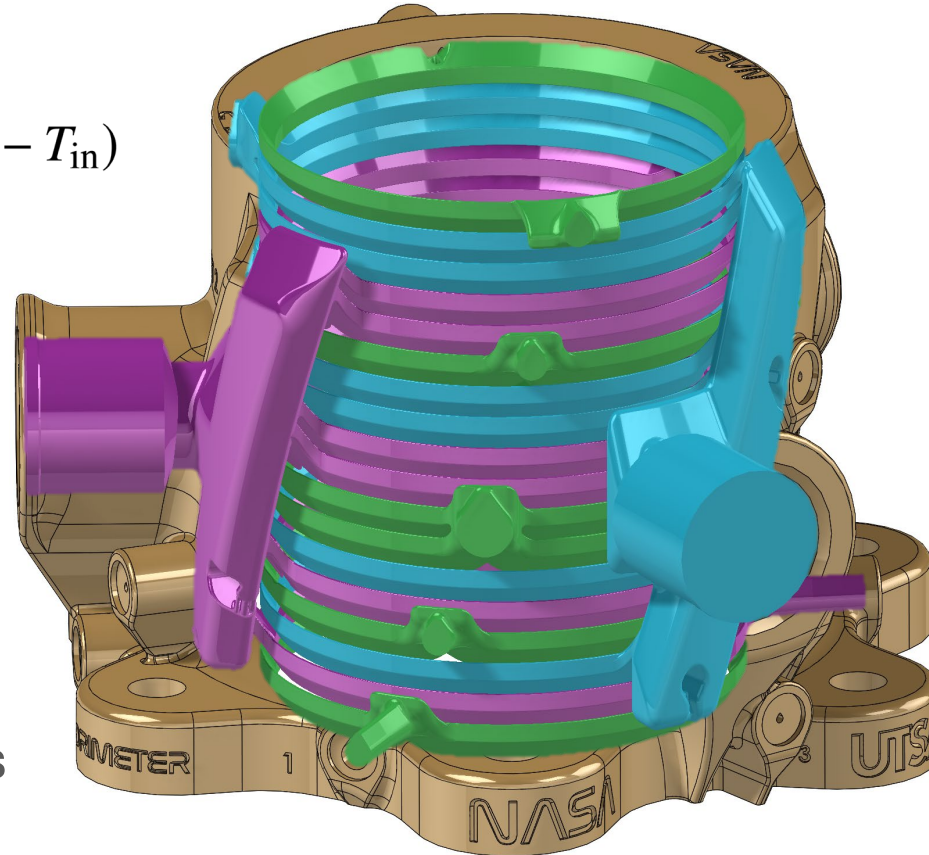

MANIFOLD 1	
Station #	Channel #
1	1
4	4
7	7
7	8
10	13
13	18

MANIFOLD 2	
Station #	Channel #
2	2
5	5
8	9
8	10
11	14
11	15

MANIFOLD 3	
Station #	Channel #
3	3
6	6
9	11
9	12
12	16
12	17

Coolant Channel Design

Nucleate boiling: locally-enhanced heat transfer

Potential for error in $dT \rightarrow q''$ measurement

Lienhard V et al. (2018)

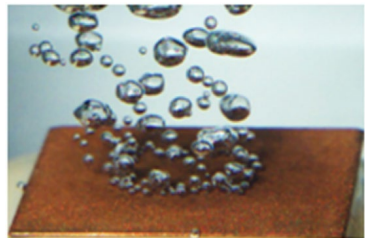
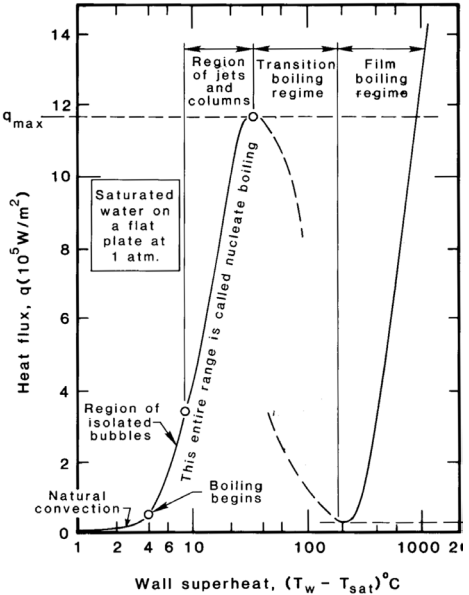

Wang et al. (2022)

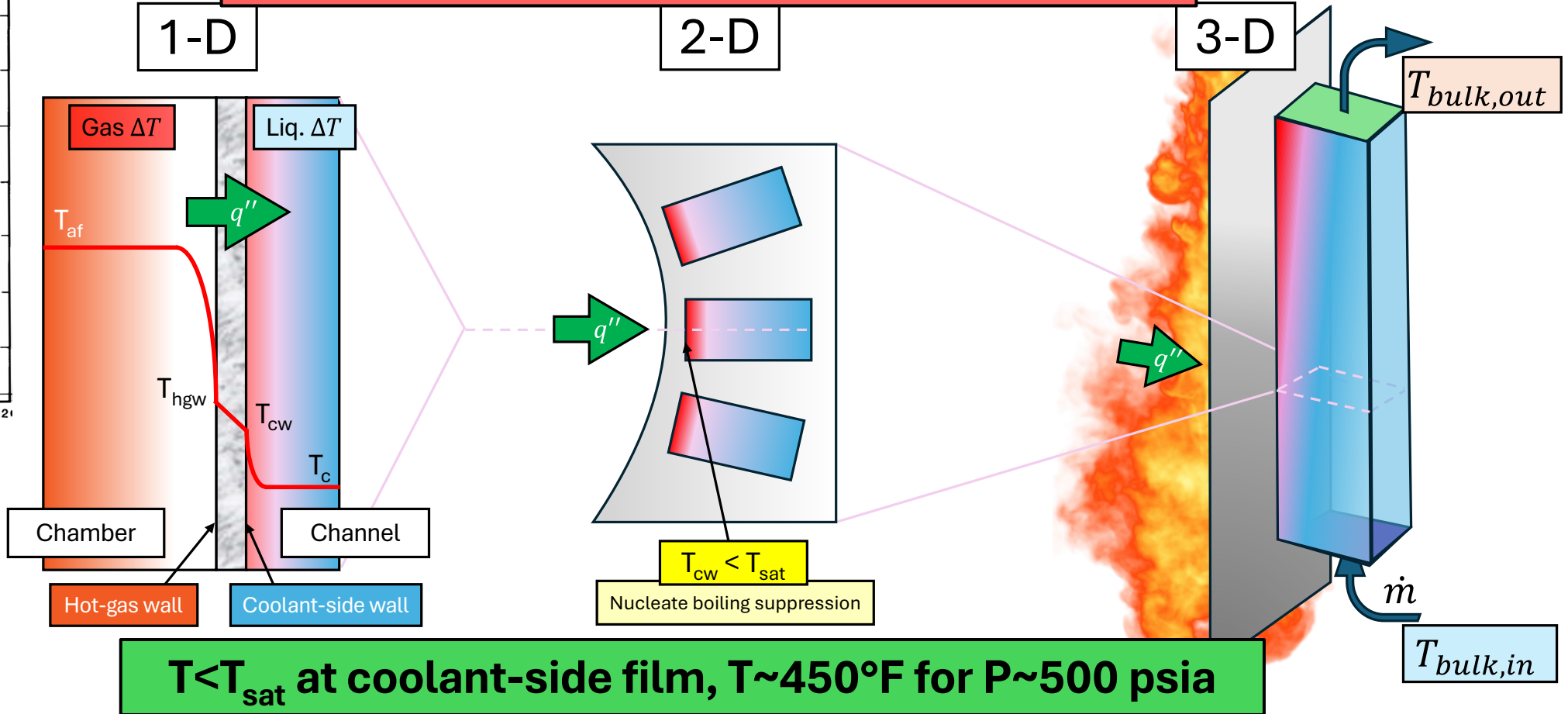

$T < T_{sat}$ at coolant-side film, $T \sim 450^\circ\text{F}$ for $P \sim 500 \text{ psia}$

Experimental Setup and Test

AM GRCo-42, post-HIP

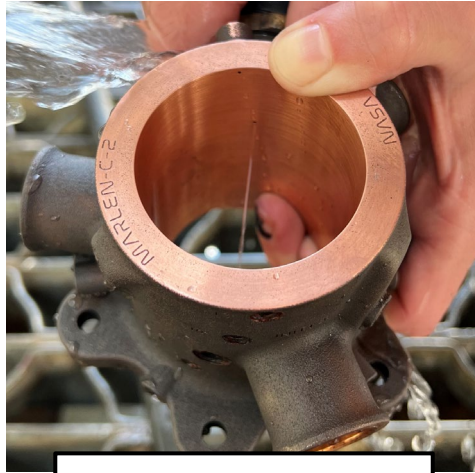

As-machined



Hot fire test

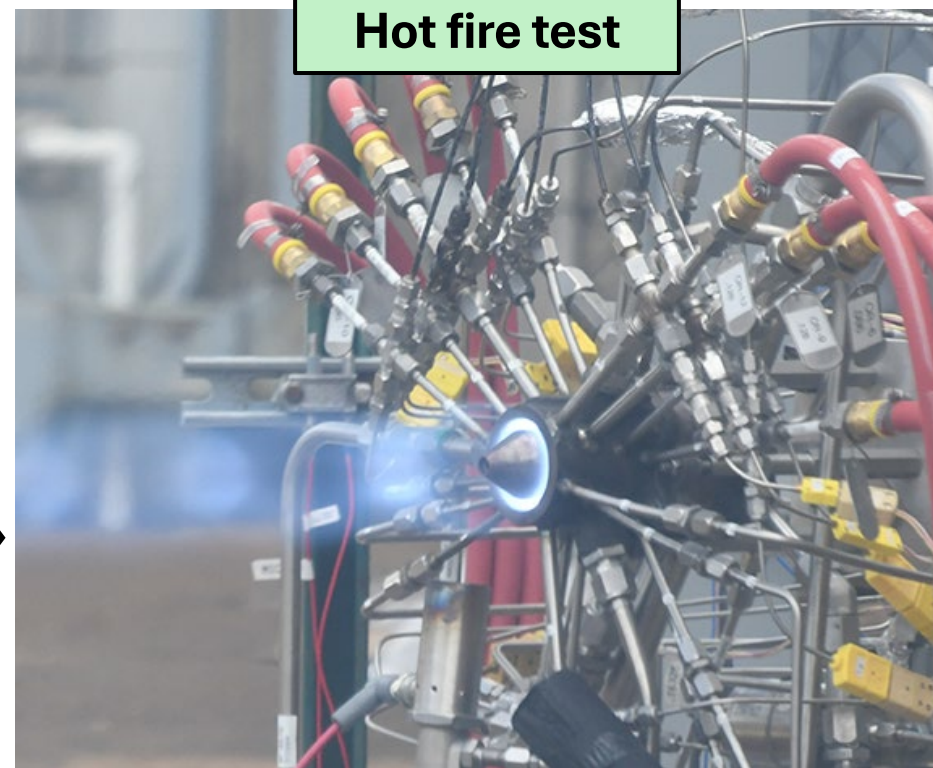

P & T msmt. upstream of orifice exits

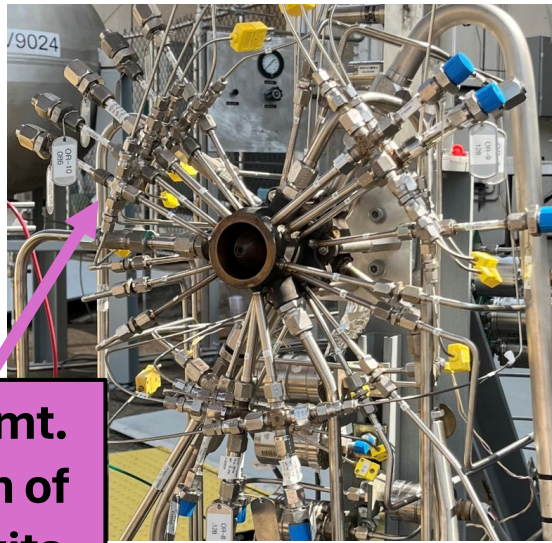

Joseph Hernandez-McCloskey

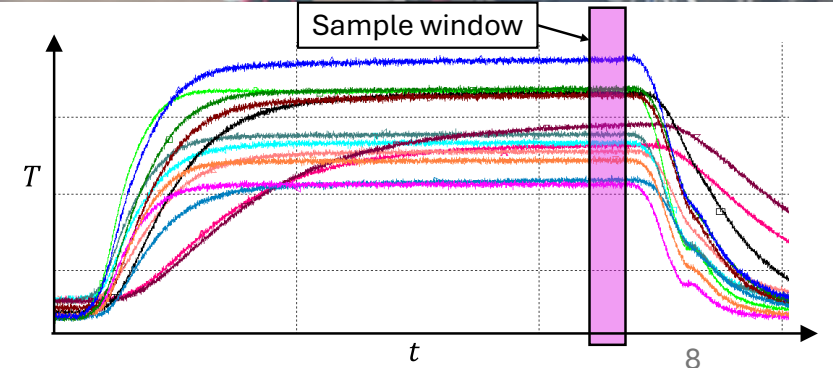



Heat Flux Trends vs. Conditions

Overall Data

- 3 of 44 tests below 100 psia Pc

heat flux

Per station

$$q'' = \frac{\dot{Q}}{A}$$

specific energy into wall

Per station

$$e = \frac{q''}{\dot{m}/A_{local}}$$

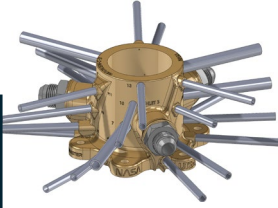

Raw Heat Flux Data

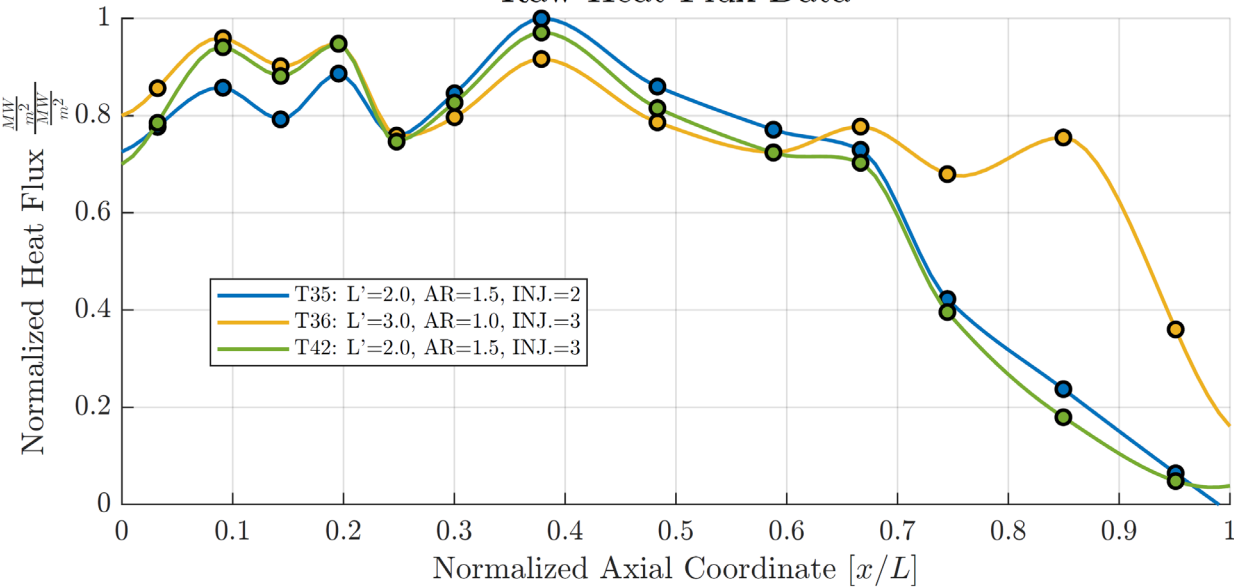

Specific Energy into Combustor Wall (Heat Flux/Local Mass Flux)

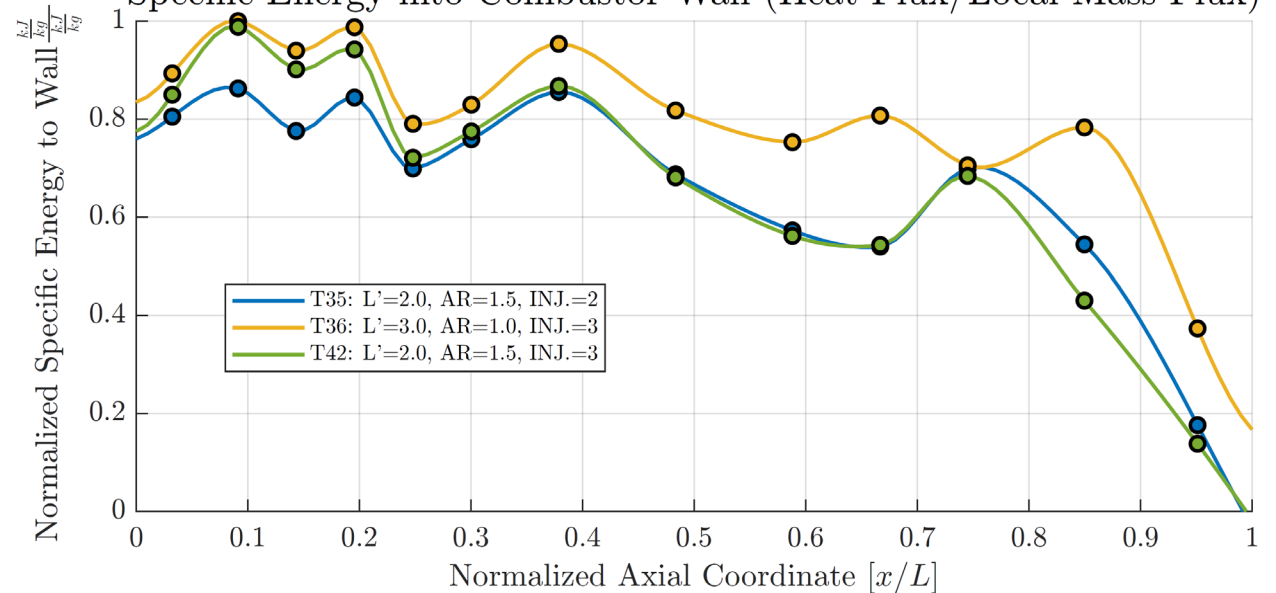

Injector Change – Specific Energy

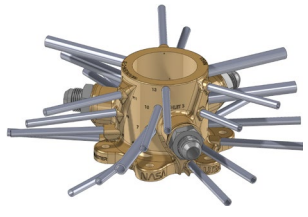
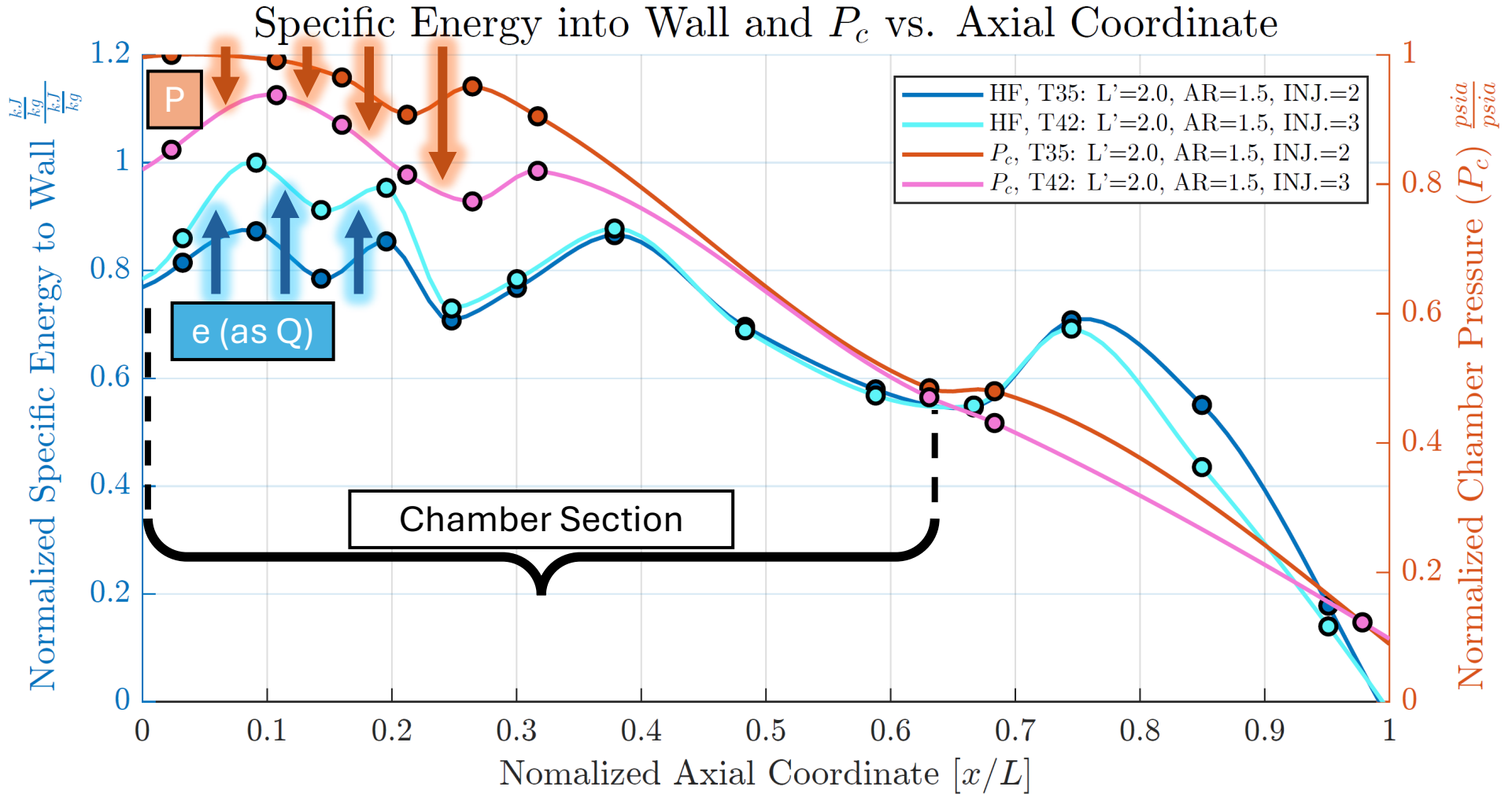

Lower P_c , higher e (as Q) to wall

Inner Body Length (L') Change

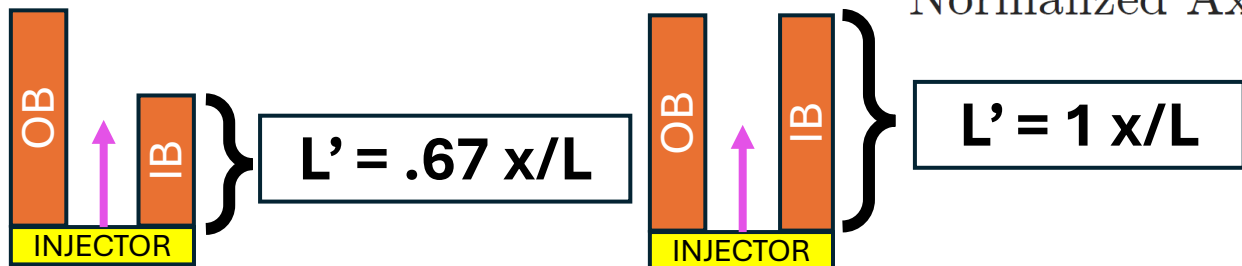
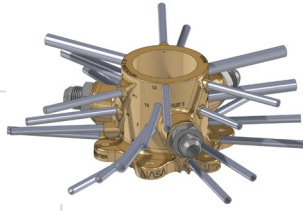
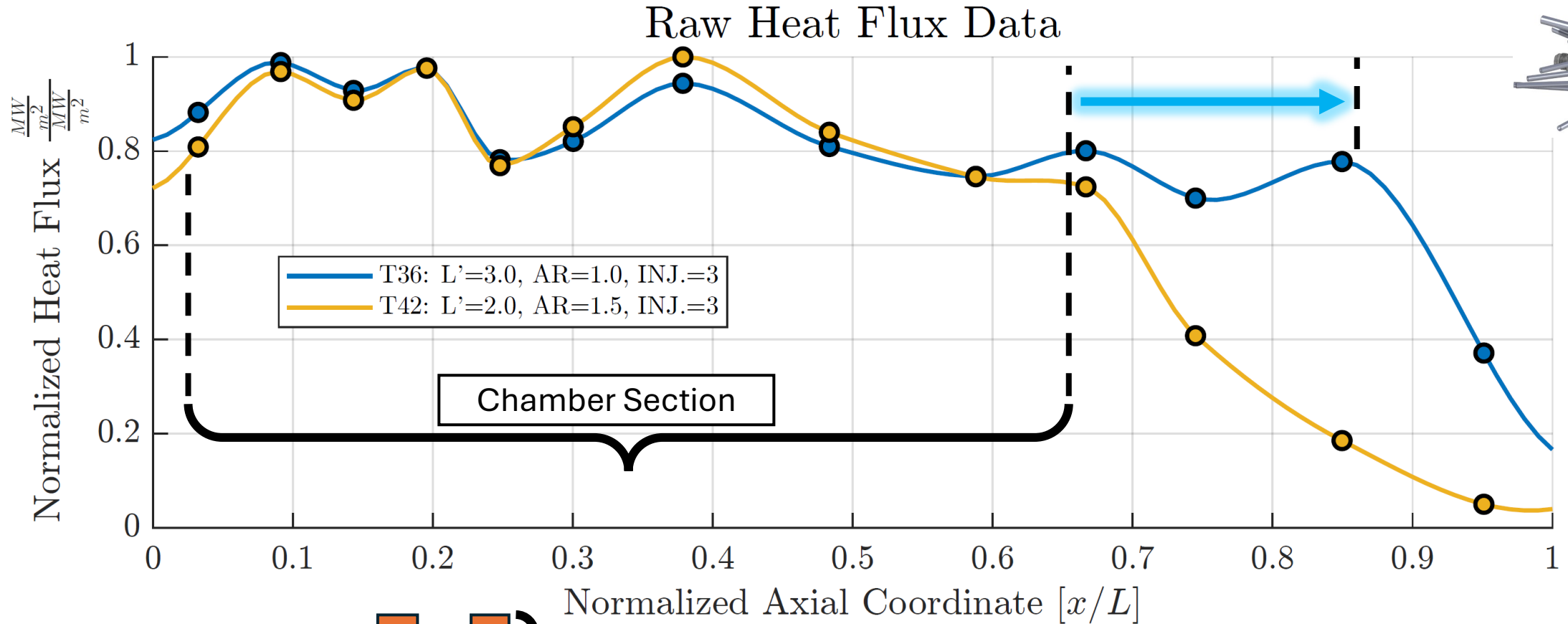

$$\Sigma \dot{Q}_3'' > \Sigma \dot{Q}_2''$$

AR Change (1.0 to 1.5)

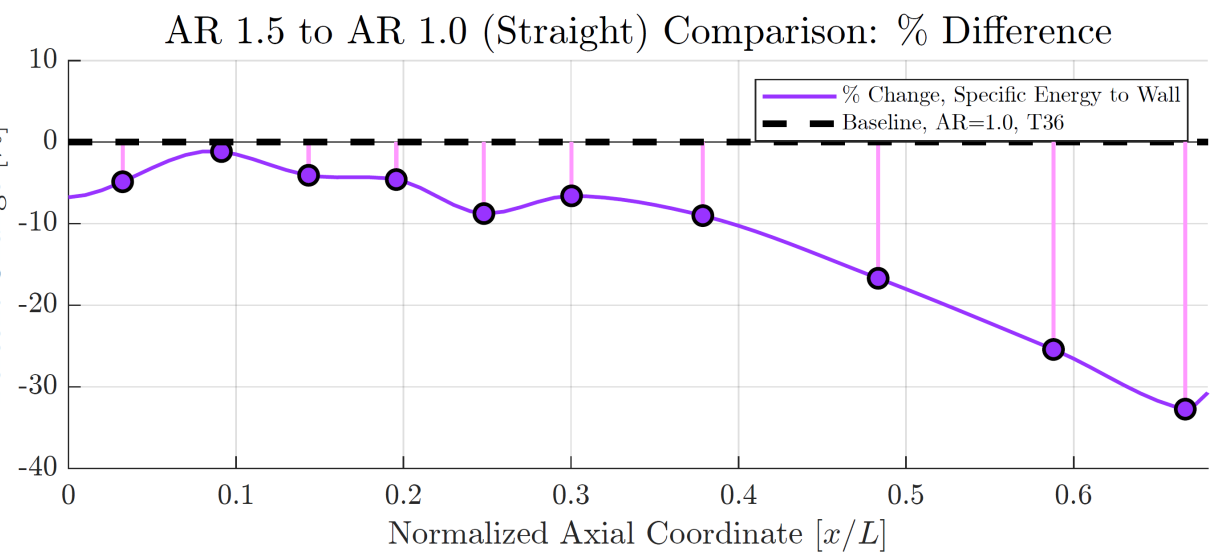
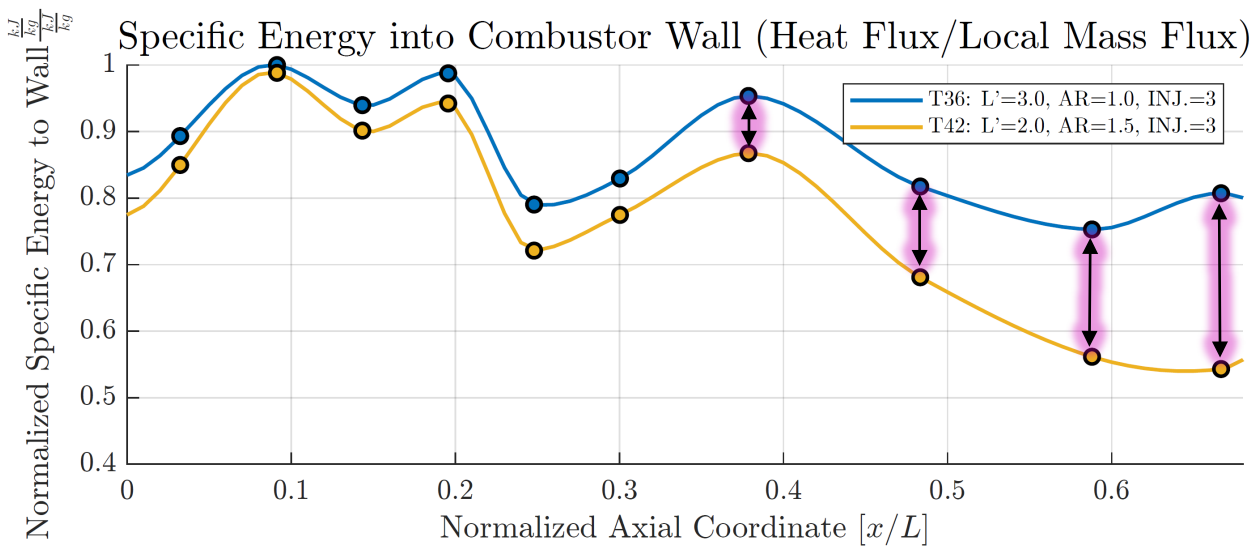
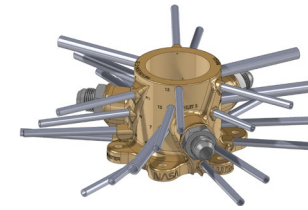
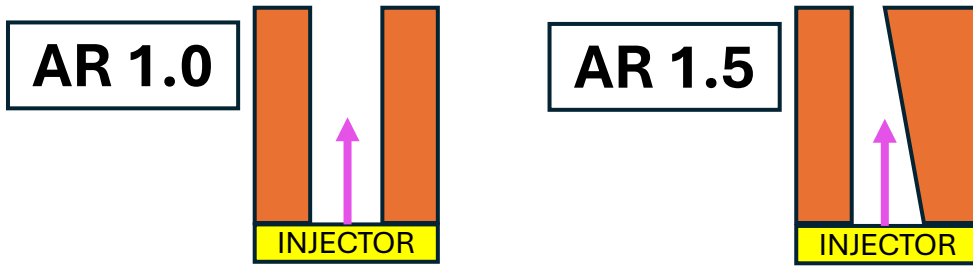

Increase AR for (given inj. mass flux), reduced e (as Q) to wall

Equivalence Ratio - Overall

$\phi > 1$

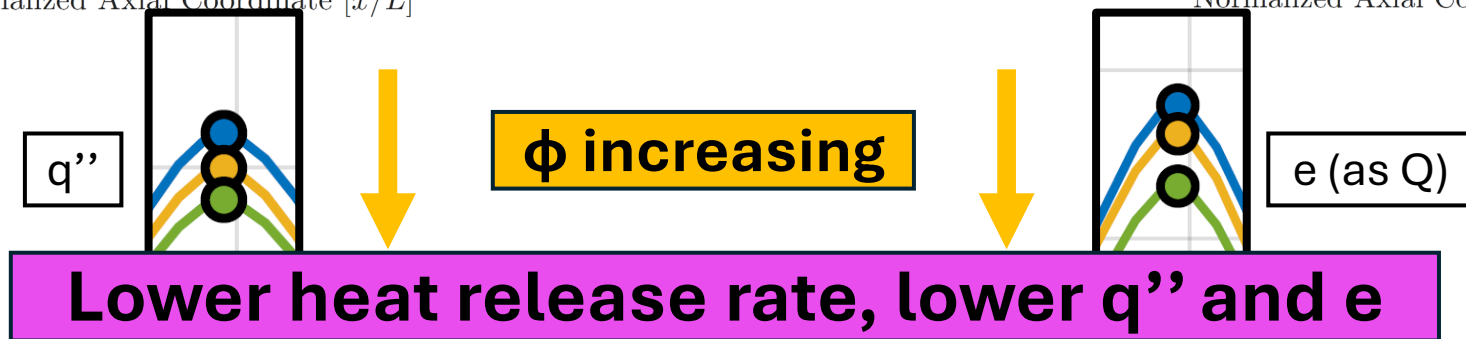
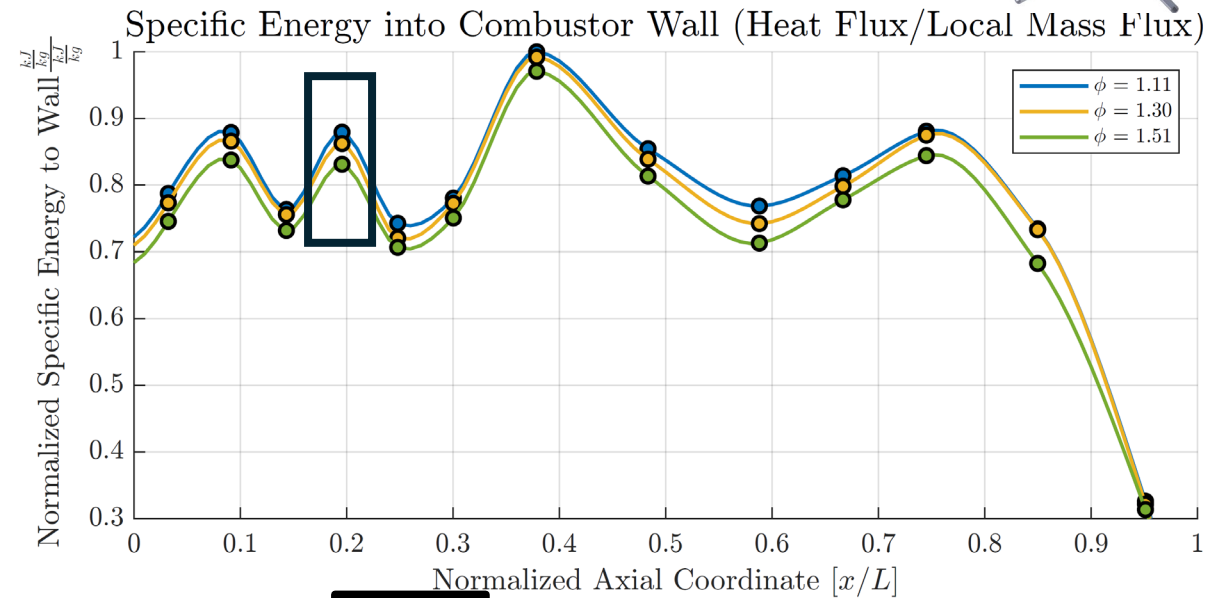
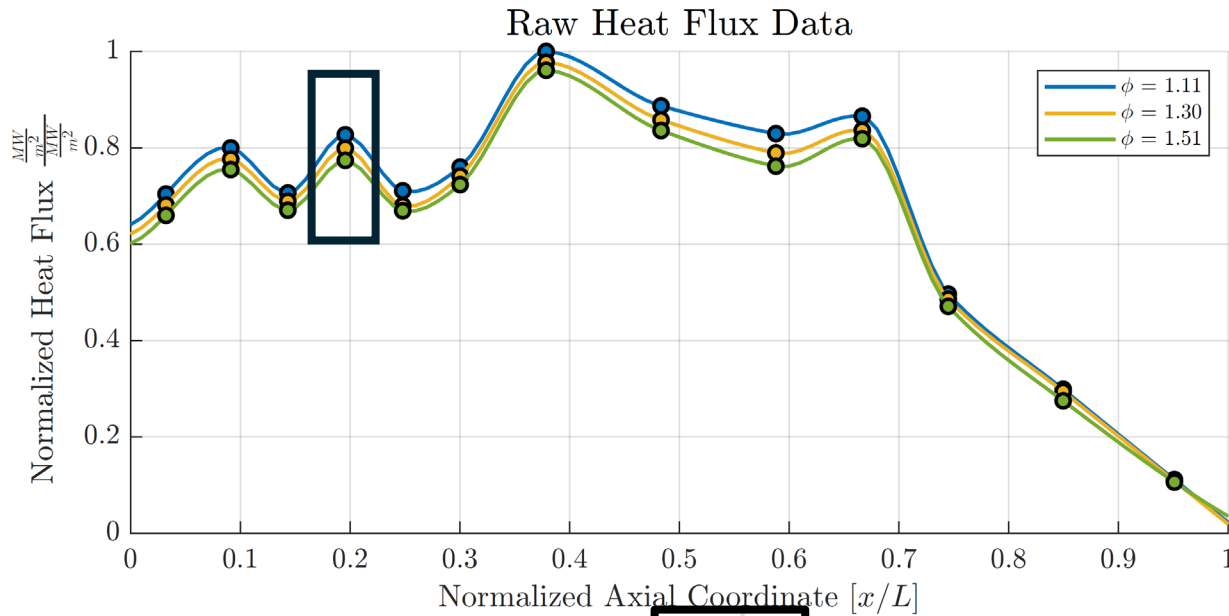
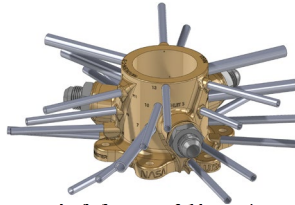

Equivalence Ratio – Fuel/Ox-Specific

$\phi > 1$

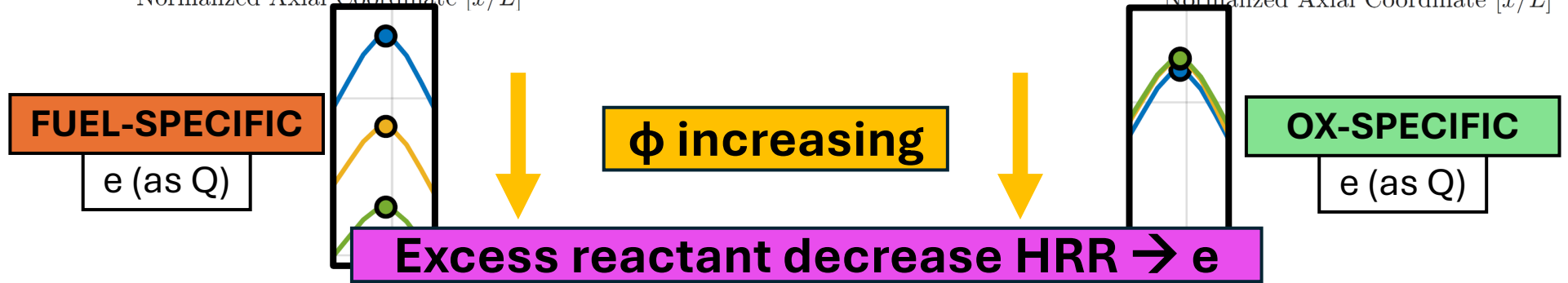
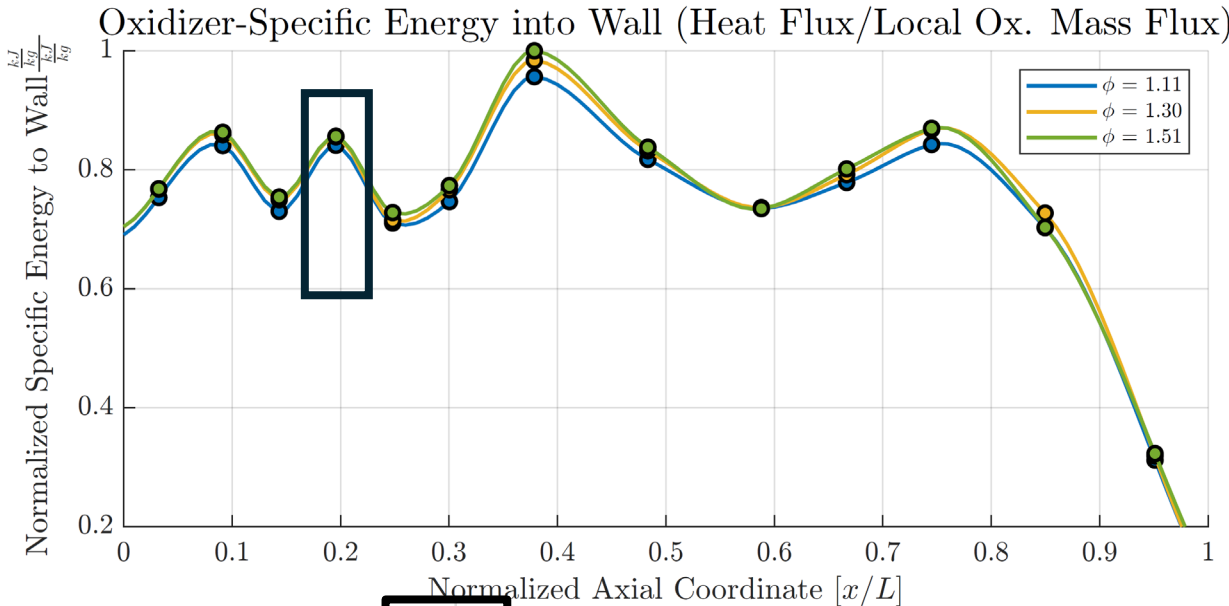
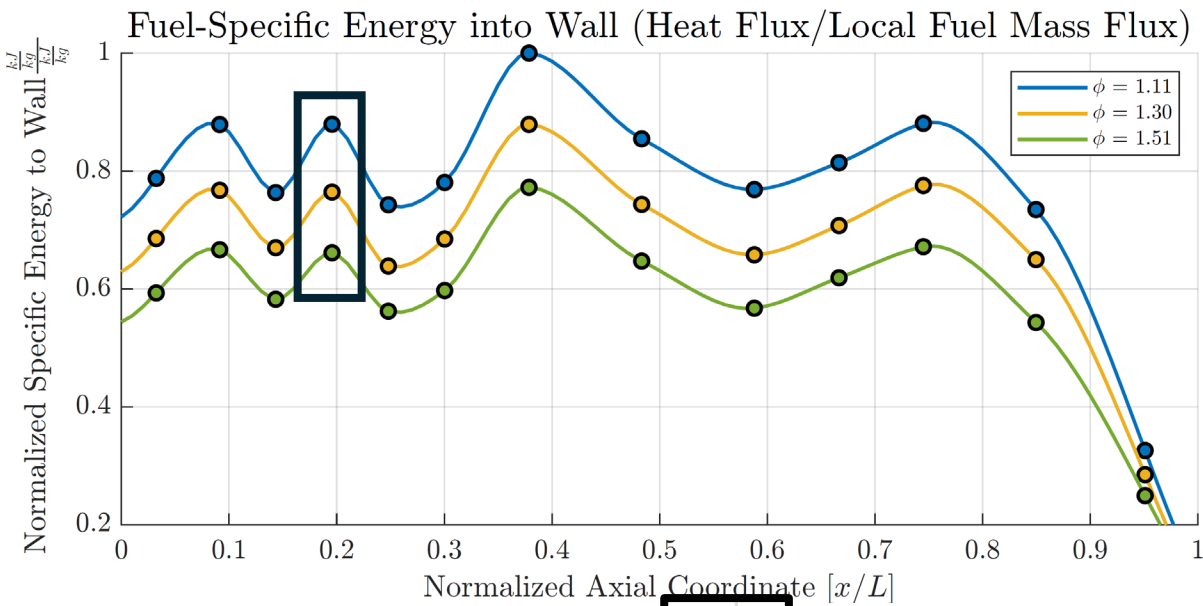
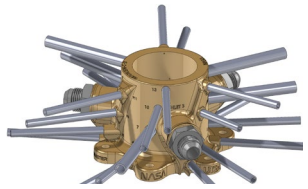



Data Transformation

3-D Effects, Conjugate Heat Transfer (CHT)

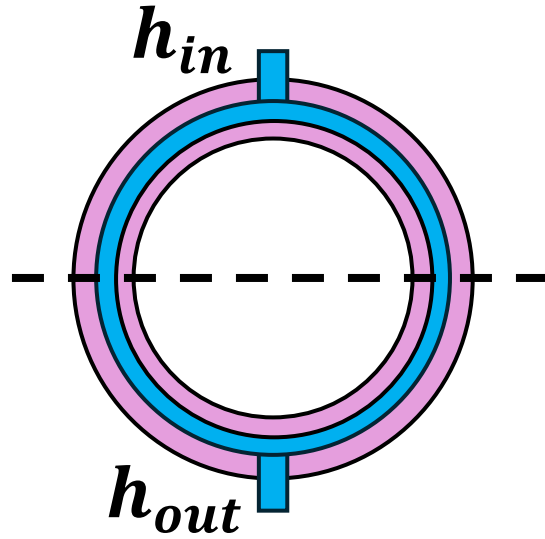

$$q''_{\Delta enthalpy} = \frac{\dot{m}\Delta h}{A}$$

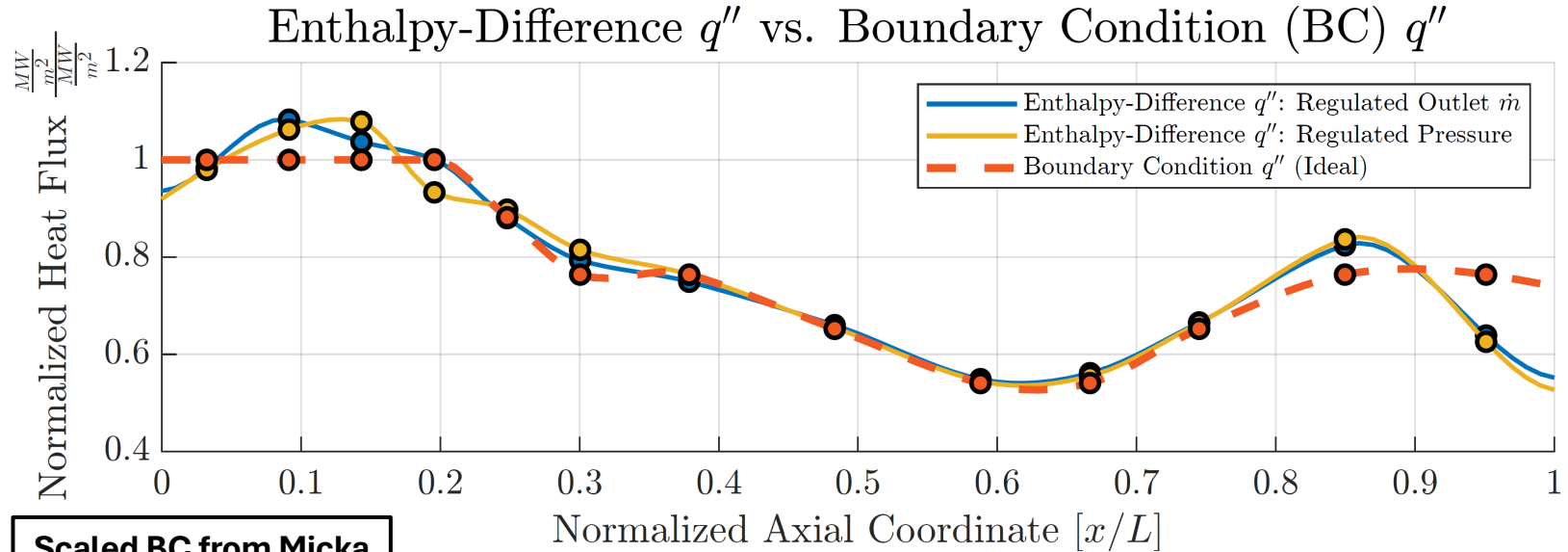

Scaled BC from Micka et al. (2021) data

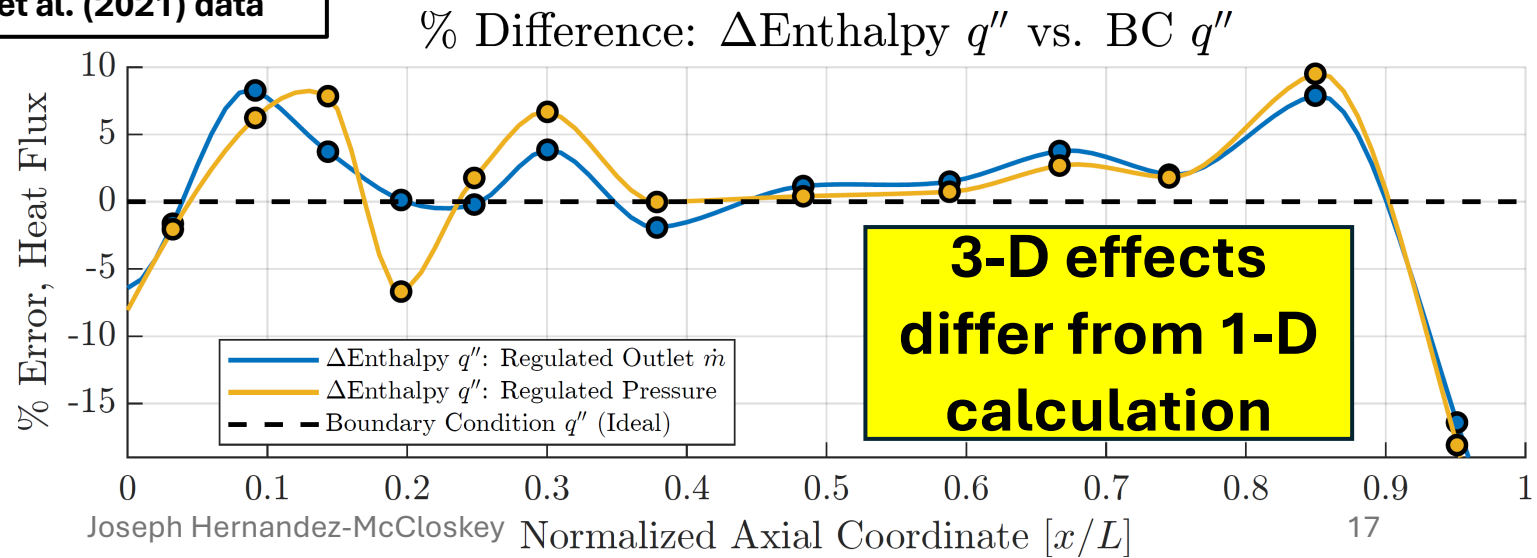

3-D effects differ from 1-D calculation

Coolant Maldistribution

Coolant Mass Flow Rate Maldistribution (44 tests)

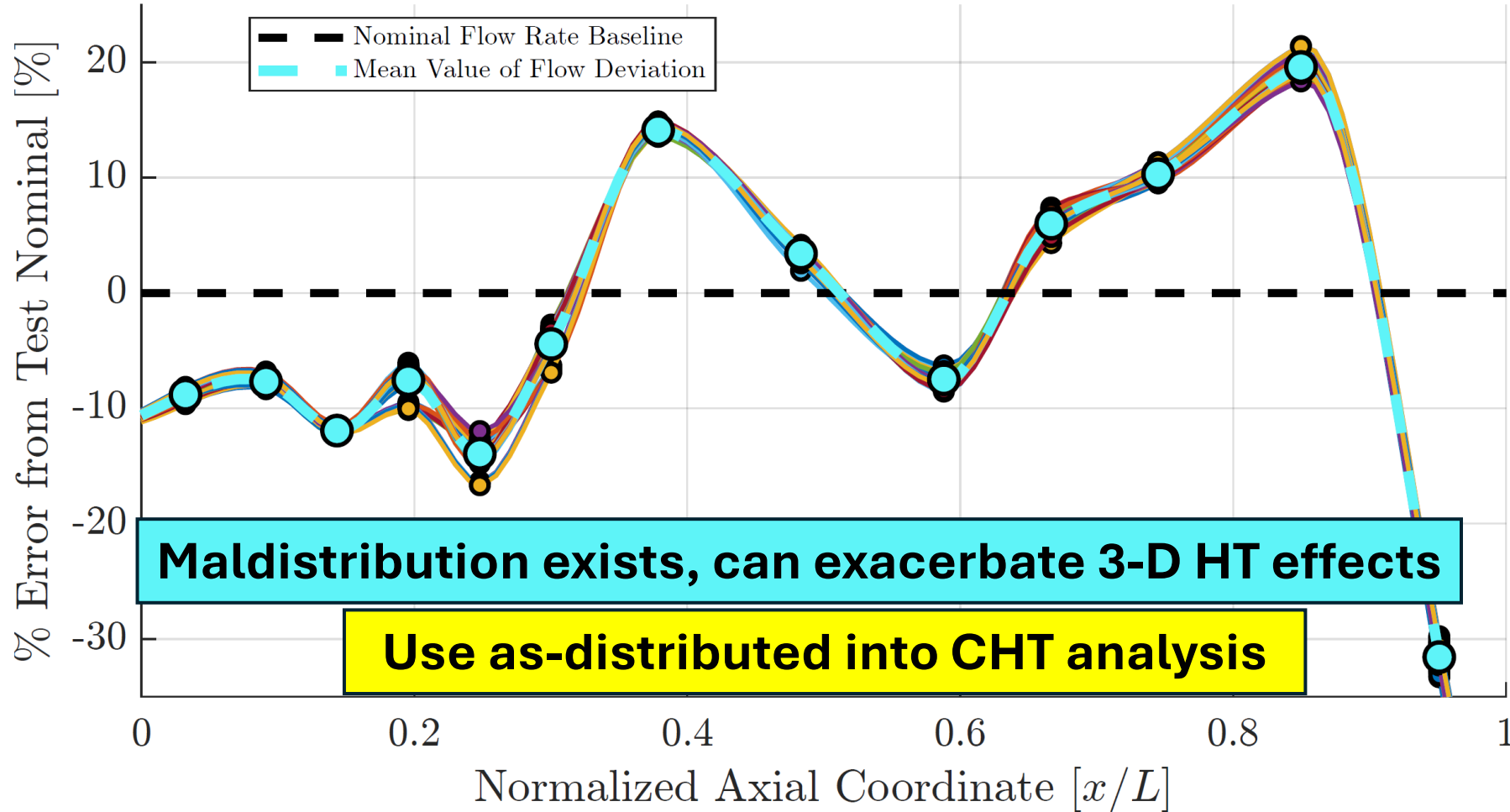
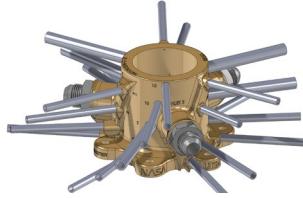

Coolant Mass Flow Deviation	
Station	Mean % Error
1	-8.82%
2	-7.67%
3	-11.93%
4	-7.56%
5	-13.94%
6	-4.42%
7	14.12%
8	3.42%
9	-7.48%
10	6.01%
11	10.30%
12	19.59%
13	-31.56%

3-D Effects with Coolant Dist., CHT

CHT-Simulated Enthalpy-Difference q'' Error

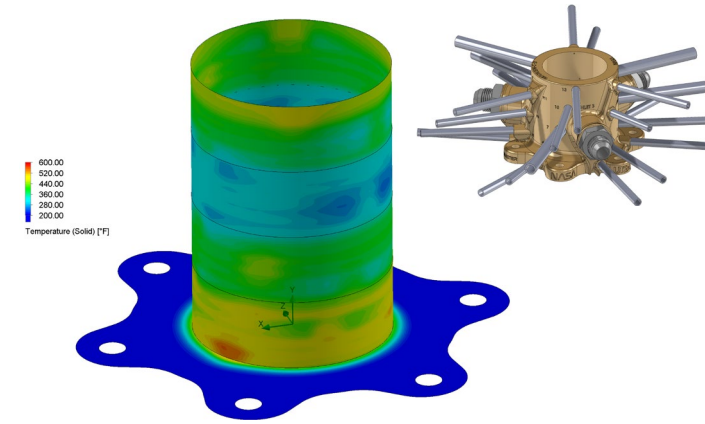
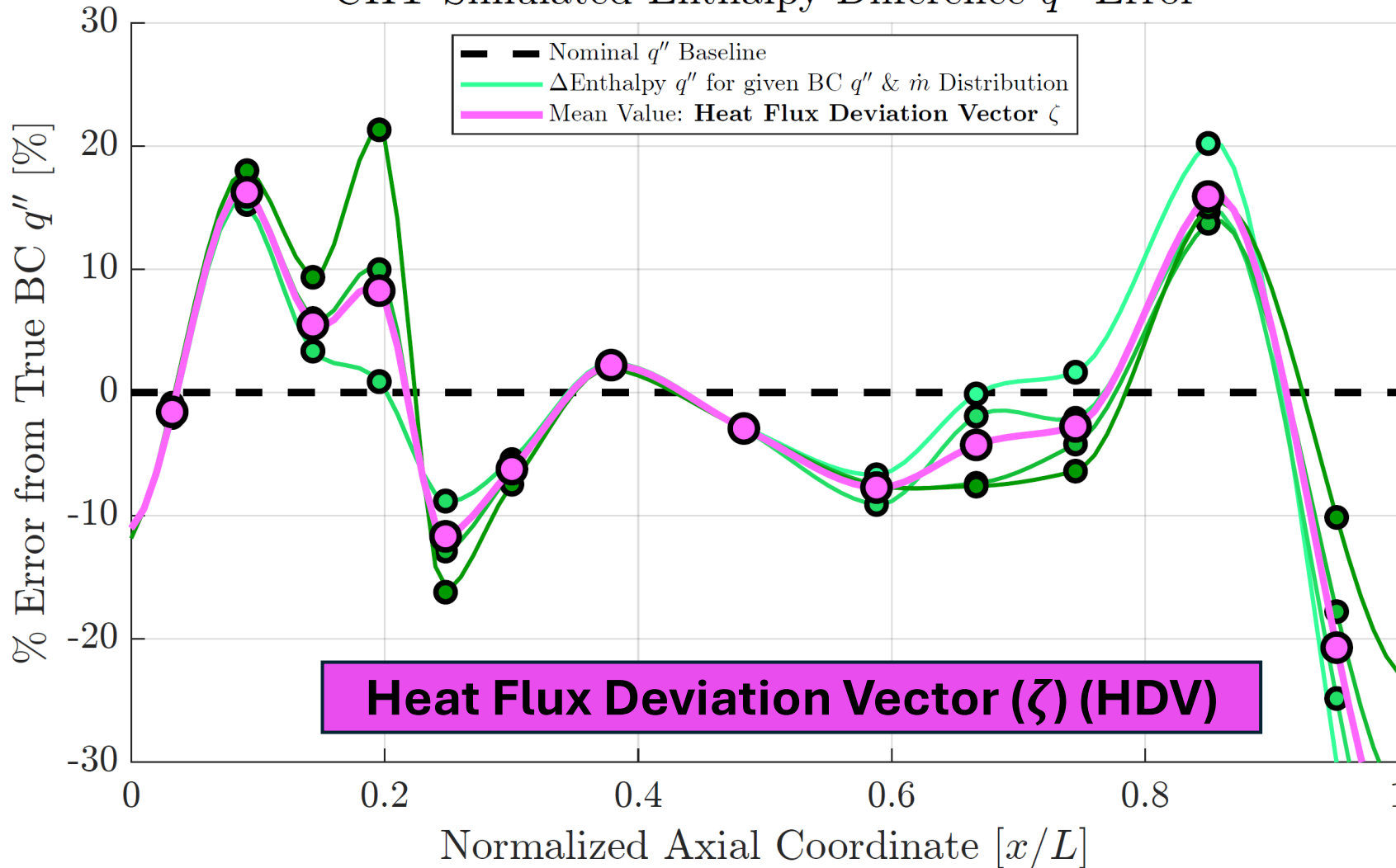

Heat Flux Deviation Vector (ζ)	
Station	Mean % Error
1	-1.58%
2	16.24%
3	5.51%
4	8.26%
5	-11.69%
6	-6.23%
7	2.21%
8	-2.93%
9	-7.72%
10	-4.26%
11	-2.76%
12	15.90%
13	-20.72%

Data Transformation

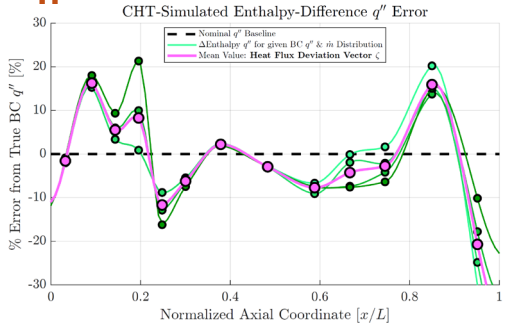

→ ζ (HDV)

$$H_{cal} = \frac{1}{\zeta}$$

Calorimeter transfer function

$$K = \left[1 - \frac{q''_{theo}}{q''_{meas}} \right]$$

$$q''_{theo} = (H_{cal} \cdot K) q''_{meas}$$

Corrected

Measured

Normalized Heat Flux $\frac{MW}{m^2} / \frac{MW}{m^2}$

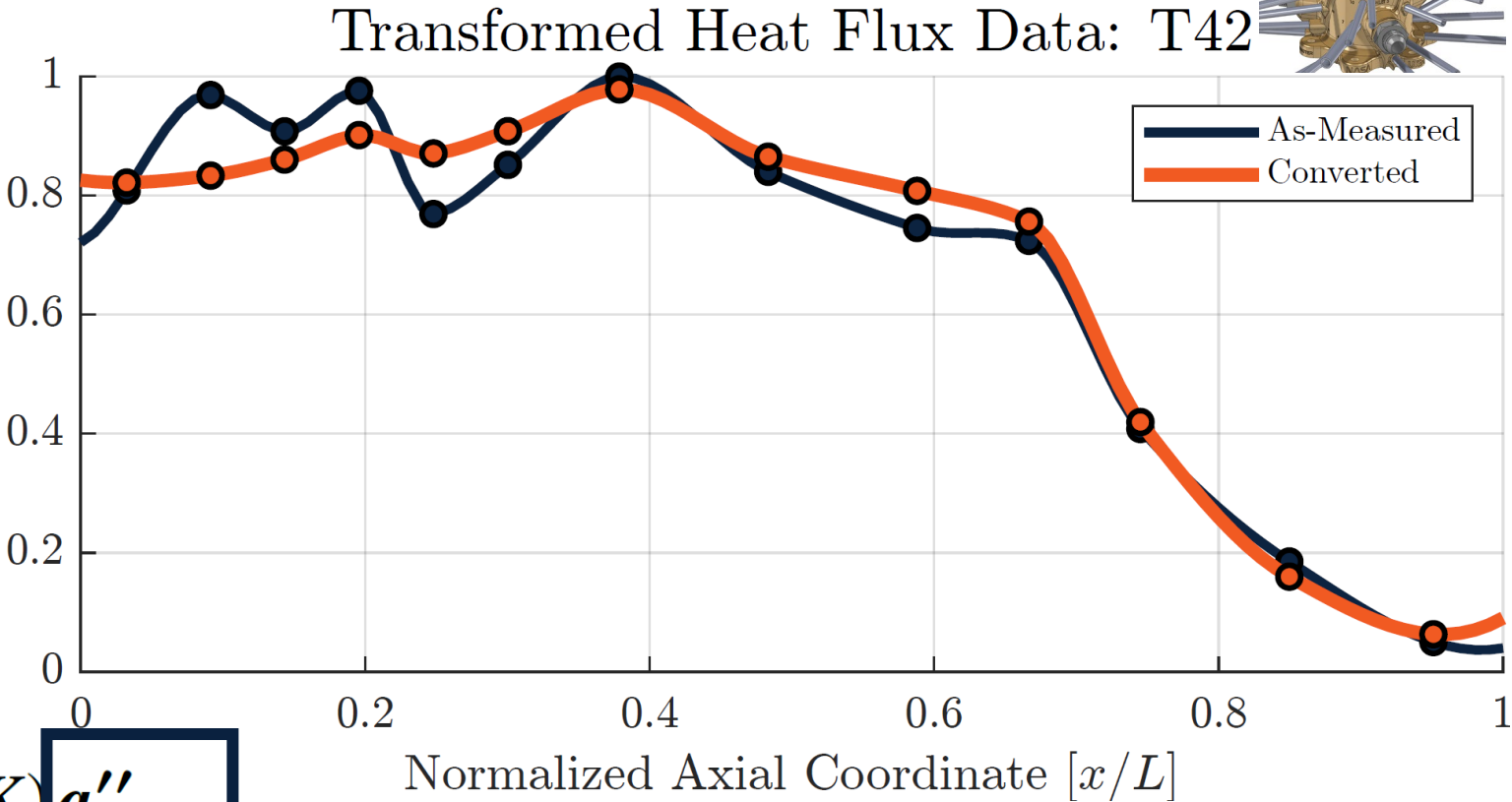



Boiling Analysis

Boiling Investigation and CHT Analysis

- Exit orifices larger than design

Coolant pressure < design
→ Saturation Temp. < design

Potential vapor generation

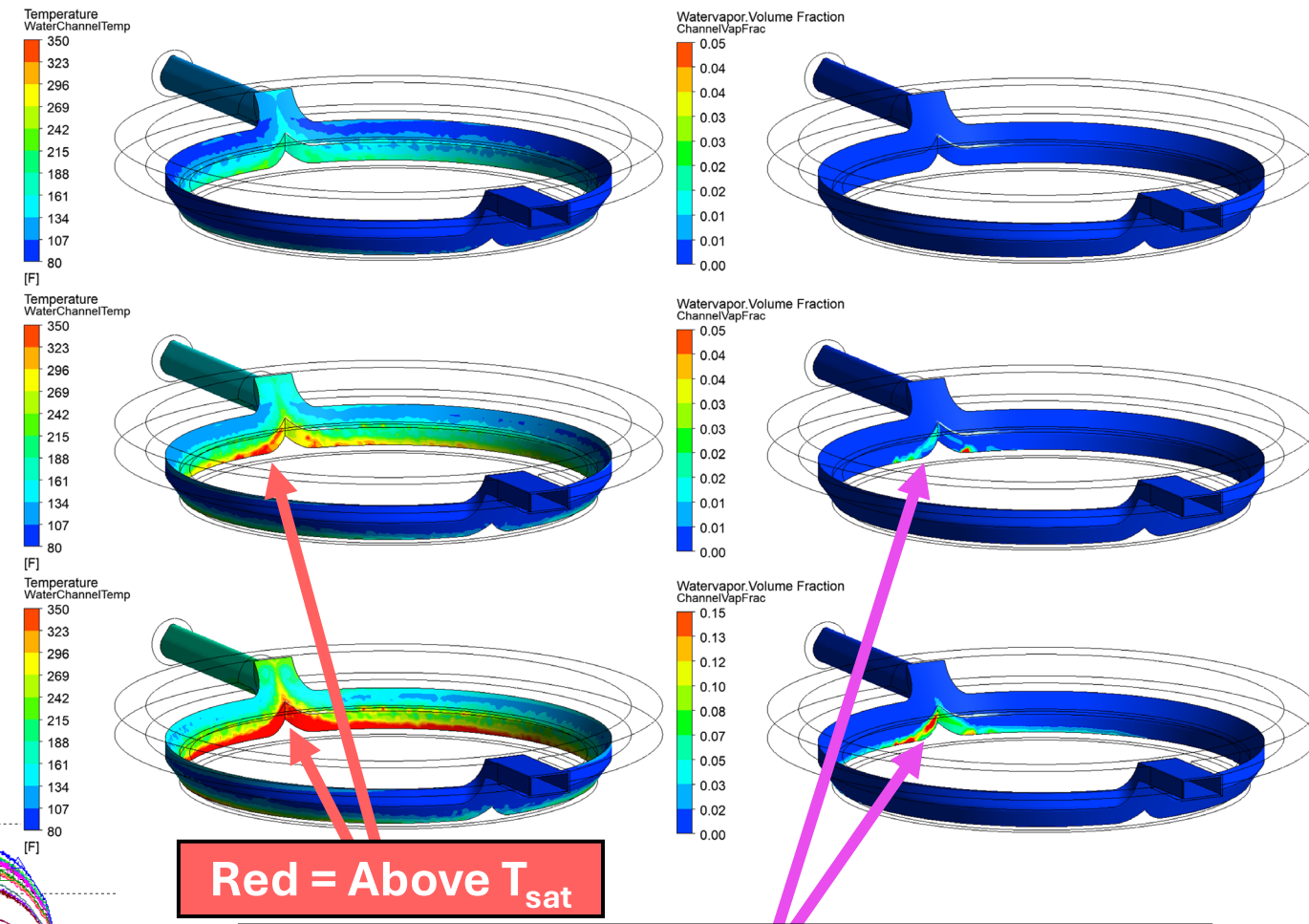
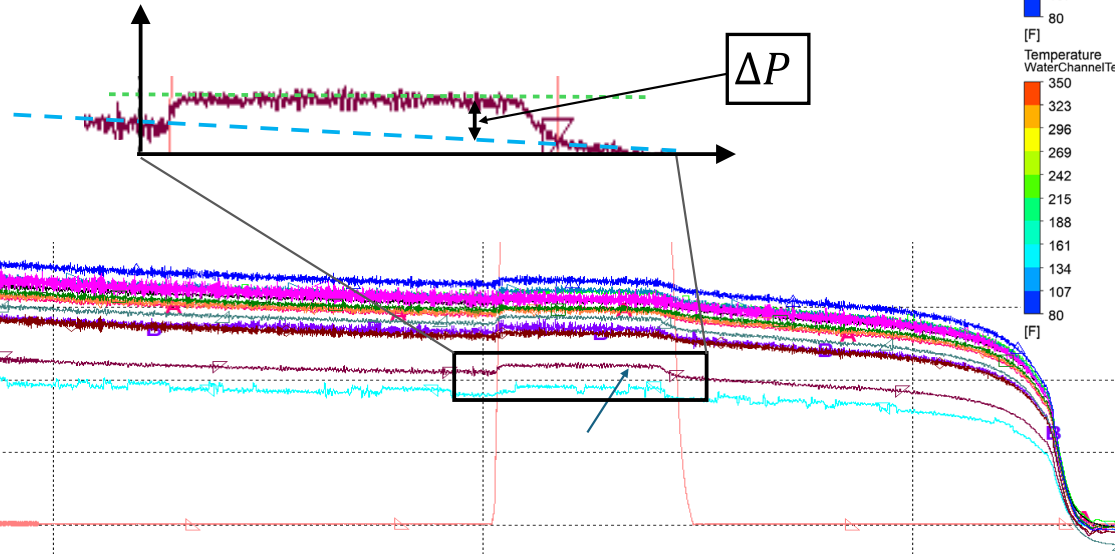

Vapor fraction present in arbitrary medium/high heat flux cases

Summary/Future Work

- Designed/manf./tested AM calorimeter hardware
- Analyzed first-order local heat flux/energy trends
- Developed calorimeter transfer function (CTF)
 - Mitigate 3-D heat transfer effects/coolant maldistribution
- Investigated presence of vapor

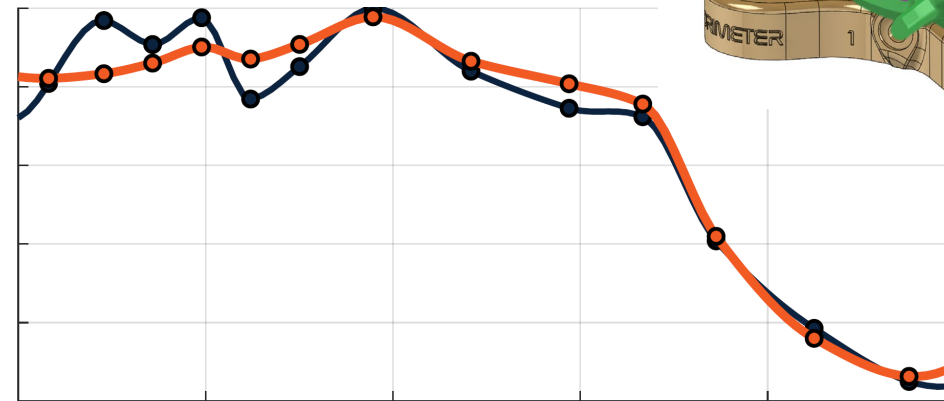
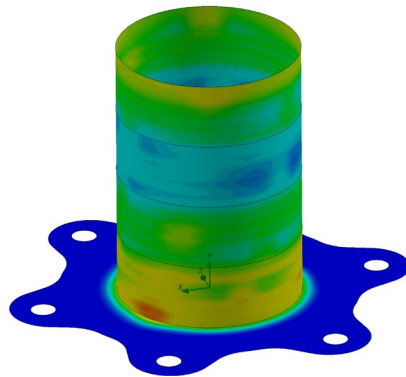
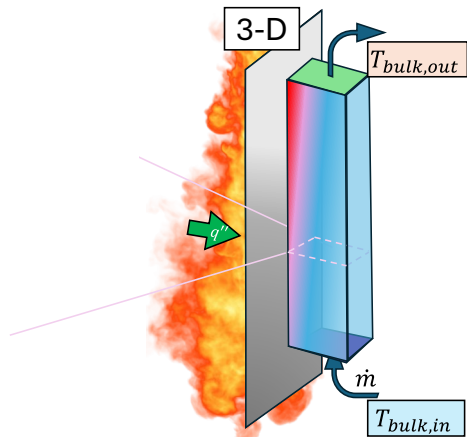
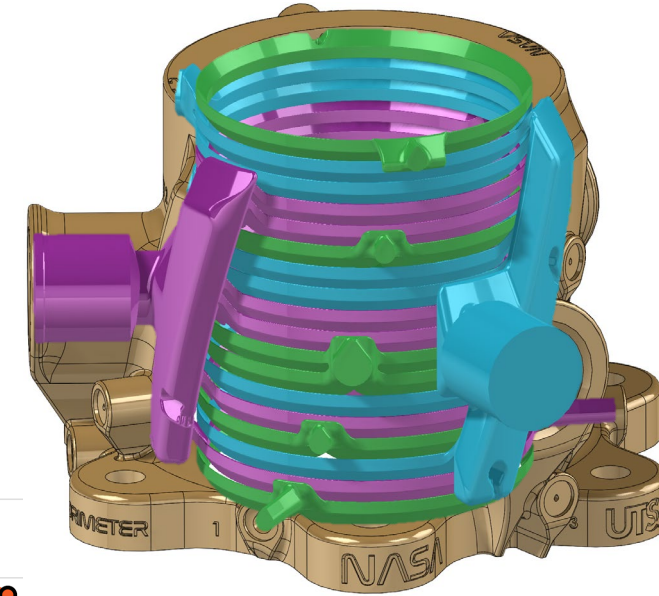

- Modify orifices for higher back pressure
- Further investigate boiling heat transfer

SIGNIFICANT NEED FOR MORE DATA!

Questions?

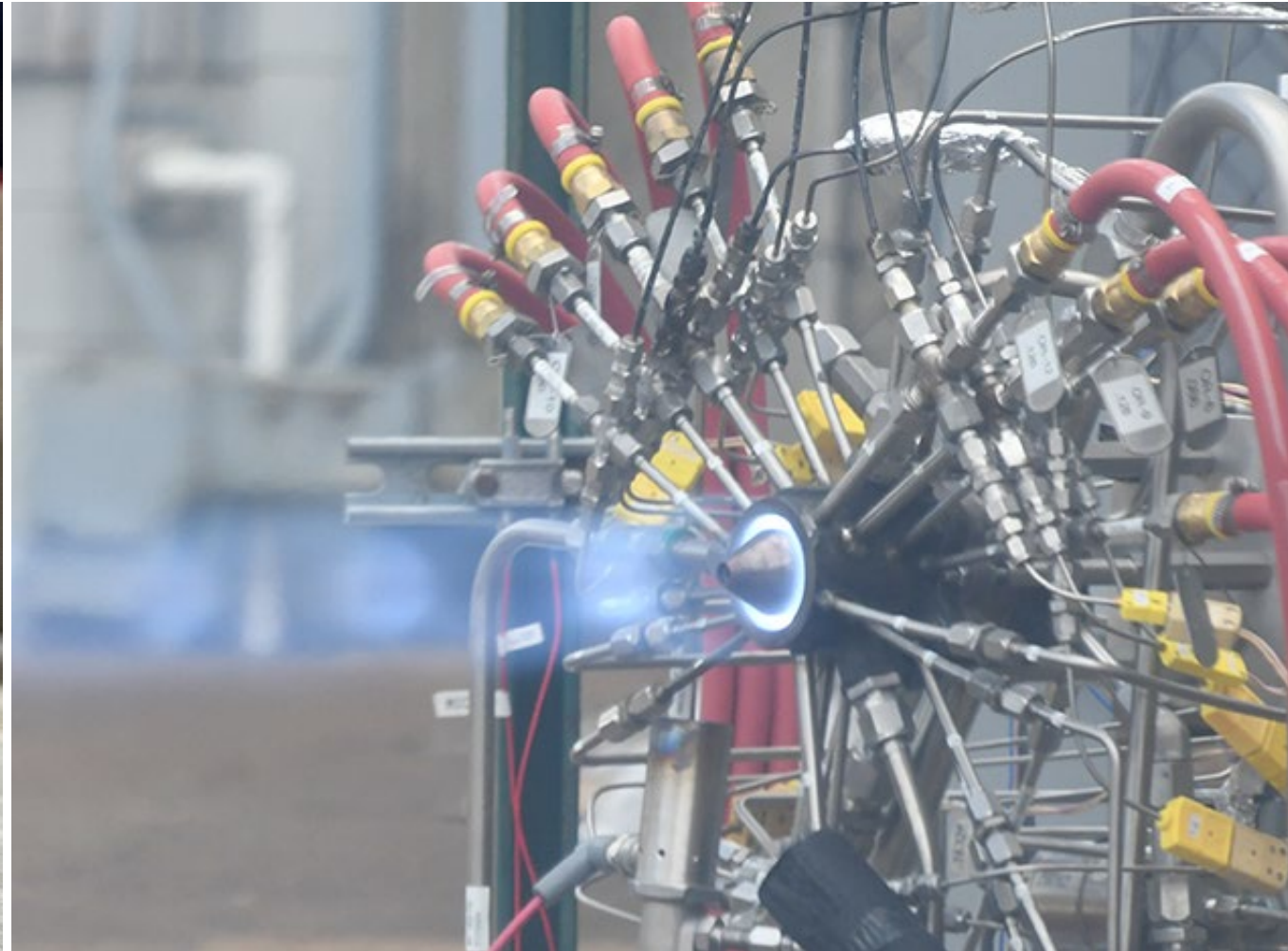
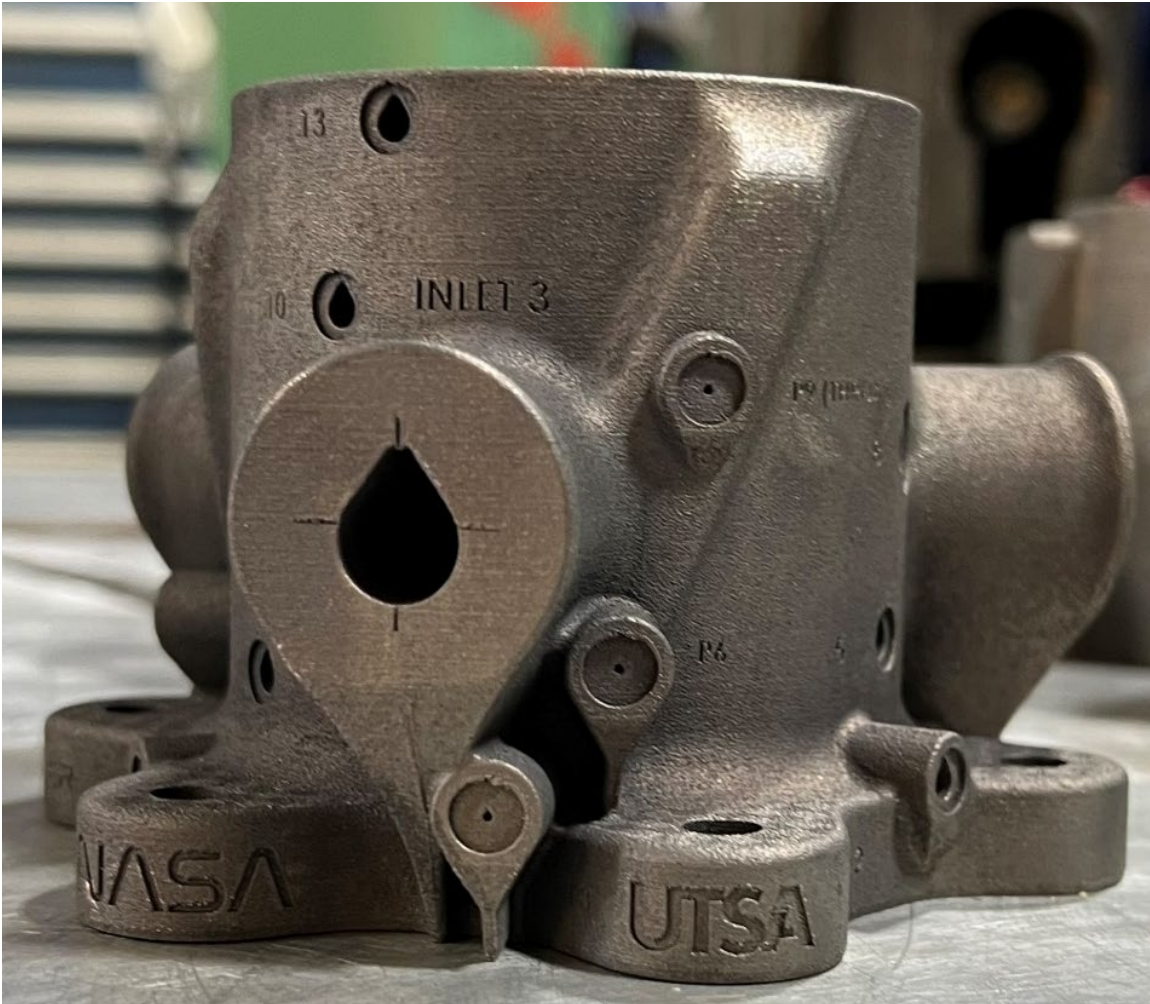

joseph.hernandez-mccloskey@utsa.edu

Injector Change – Comparison

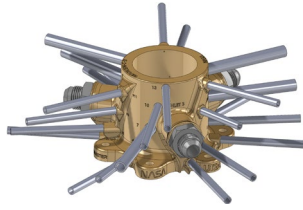

Inj. 3 to Inj. 2 Comparison: % Difference (vs. Inj. 2 Value)

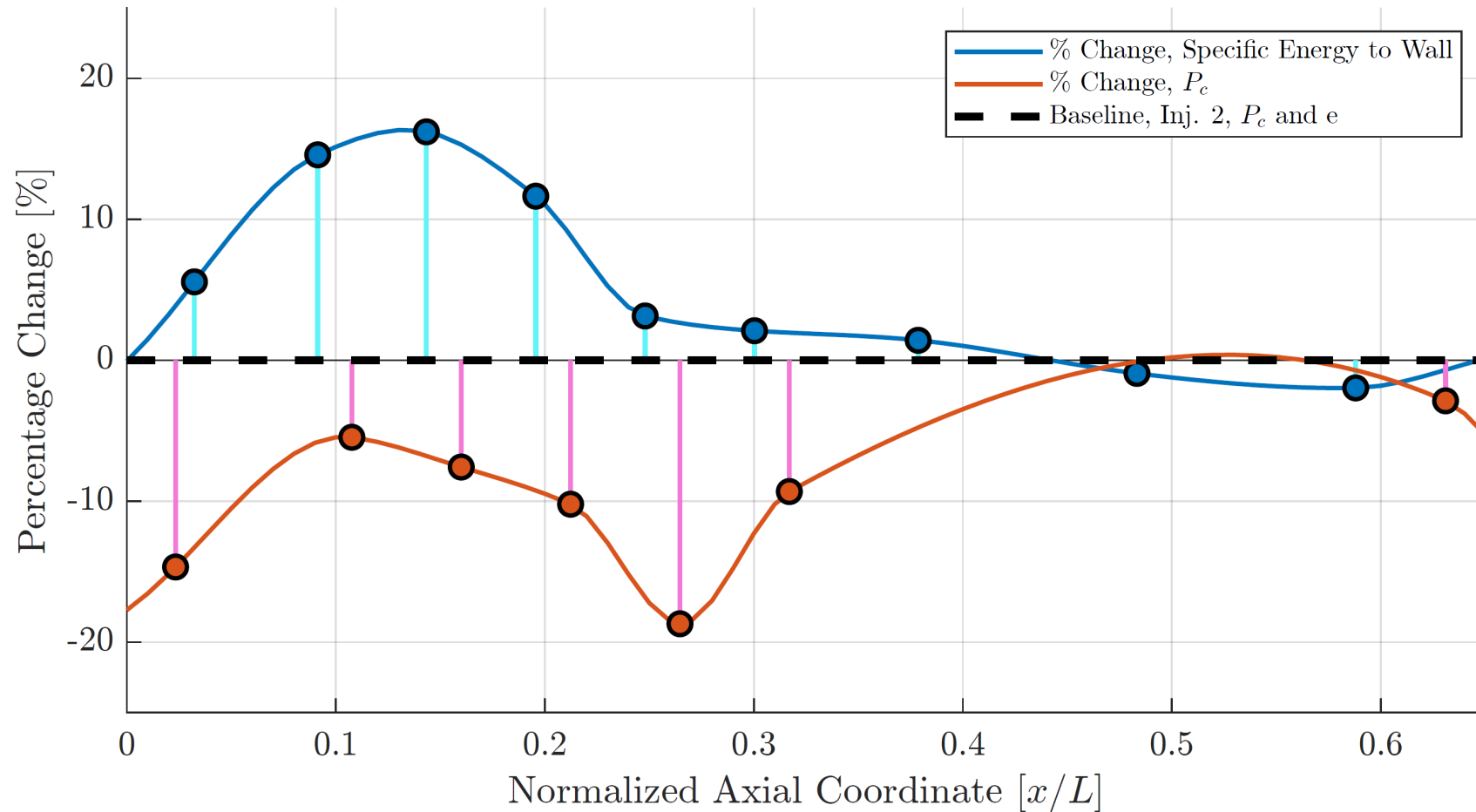

Wave Mode Shift - Thermocouple Data

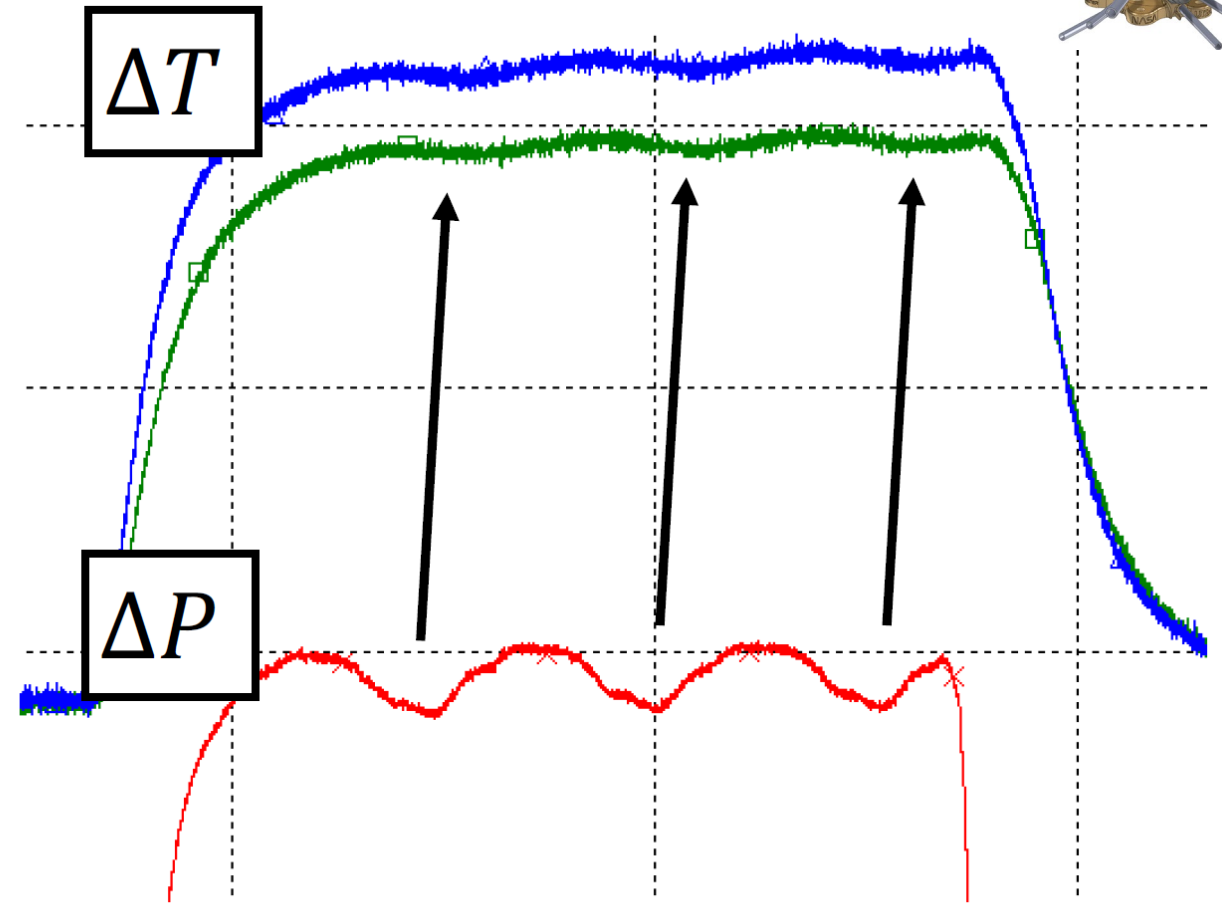
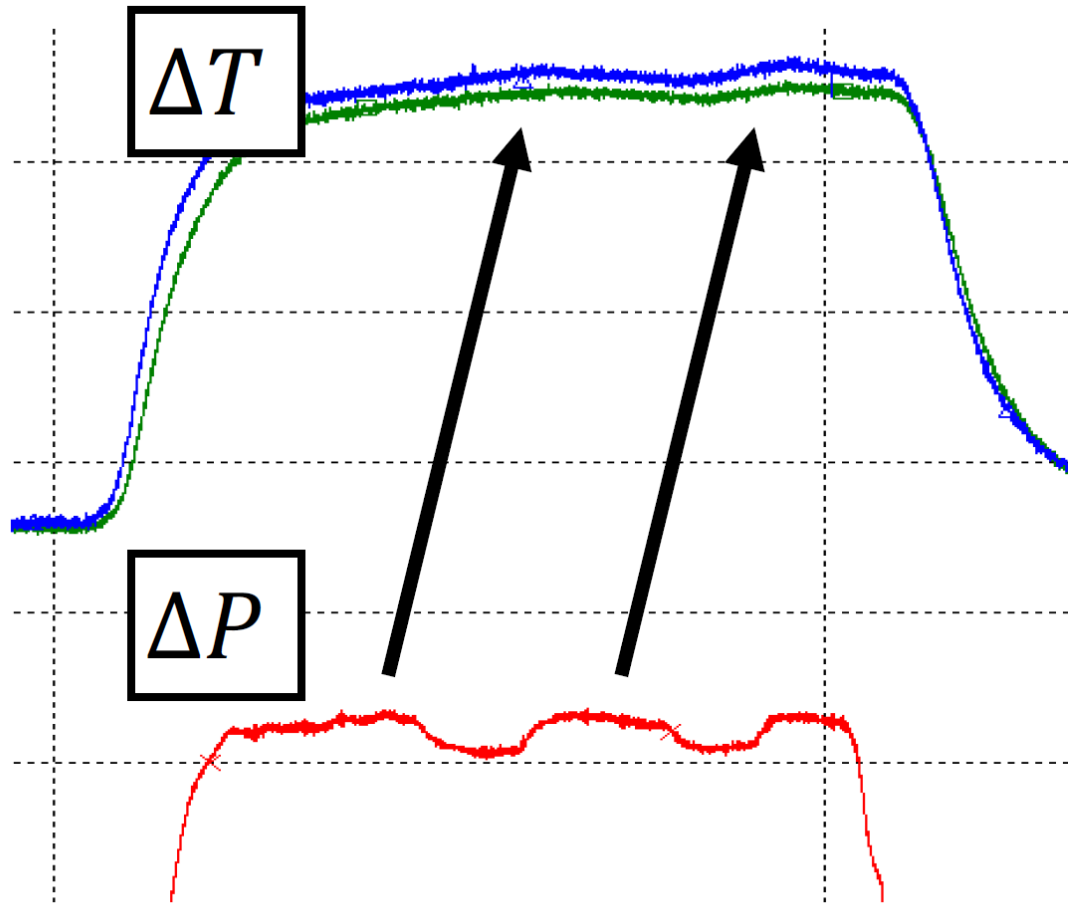
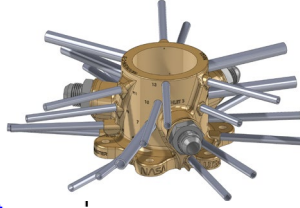

Design Simulations – 1

- Conjugate heat transfer sims using prescribed boundary conditions from scaled Micka et al. (2021) data

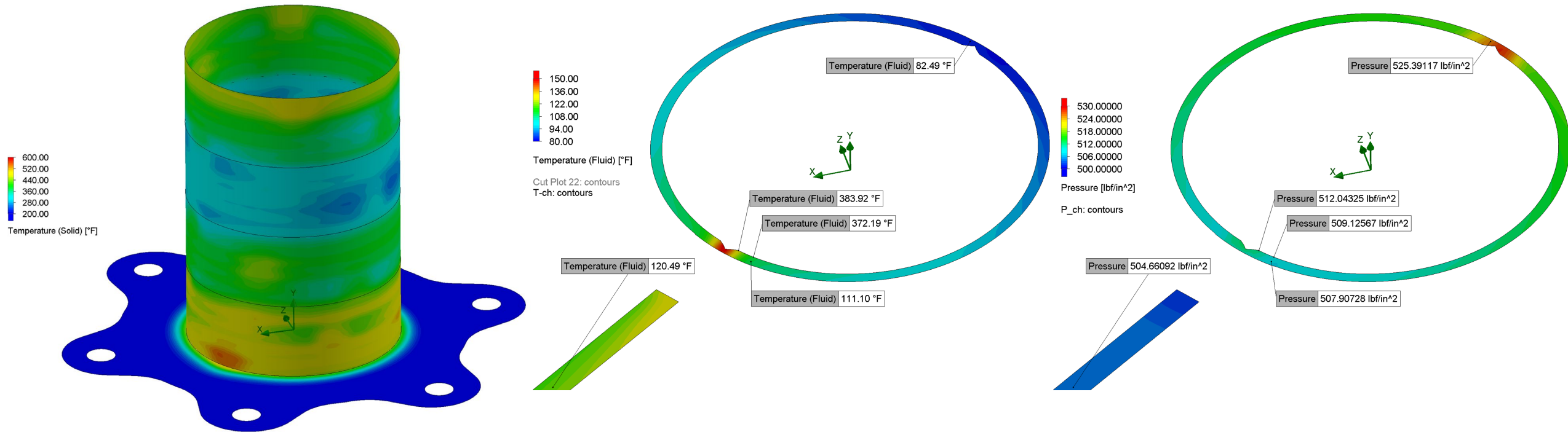

Design Simulations – 2

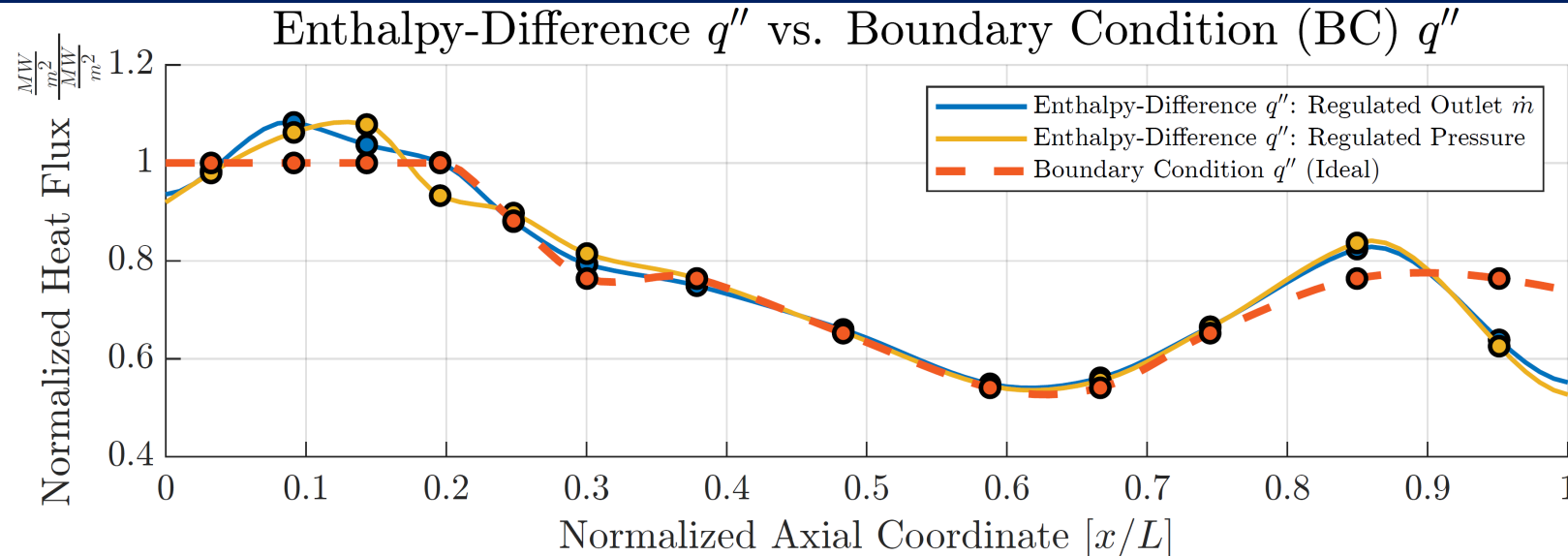

Prescribed boundary conditions from scaled Micka et al. (2021) data

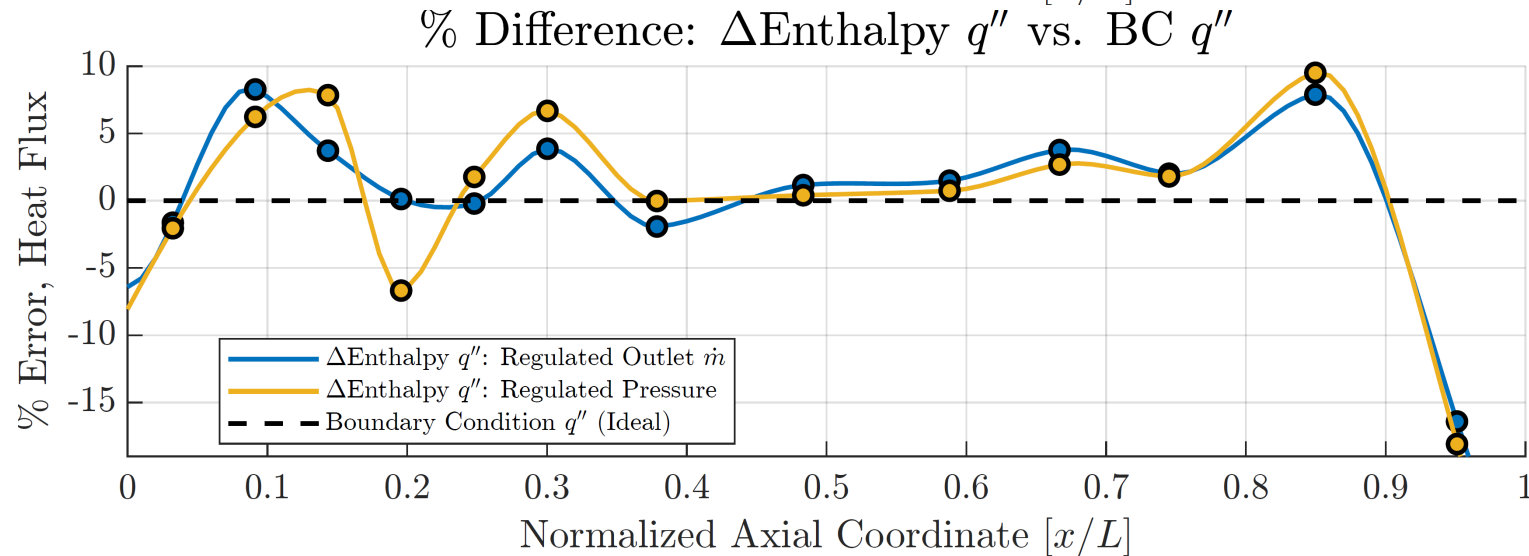

Additional Transformed Data

Transformed Heat Flux Data: T35

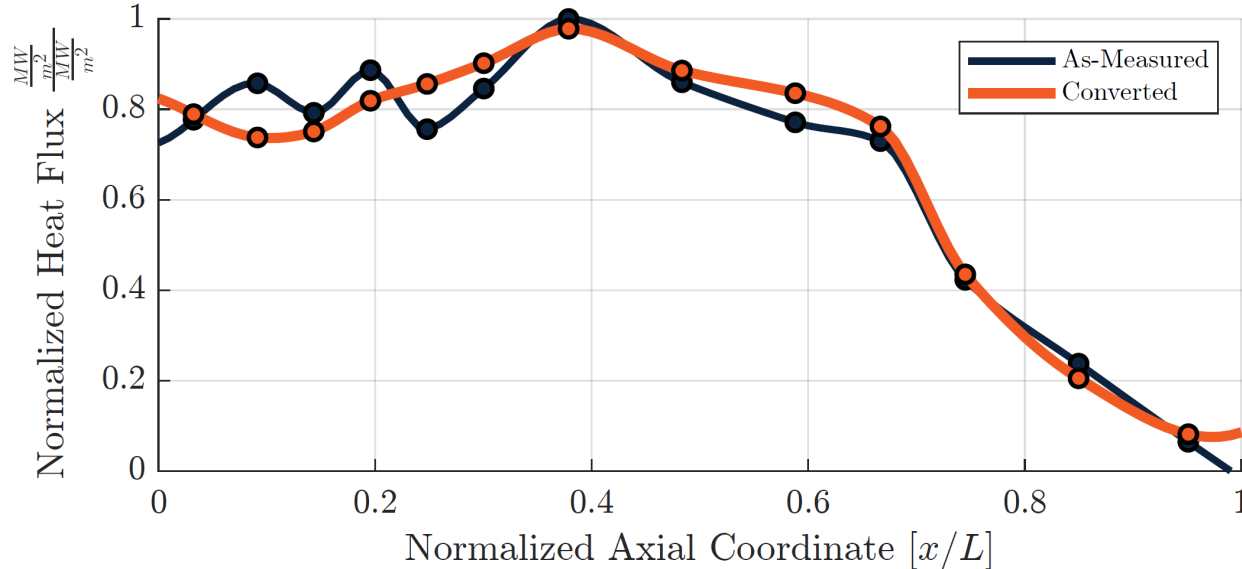

Transformed Heat Flux Data: T36

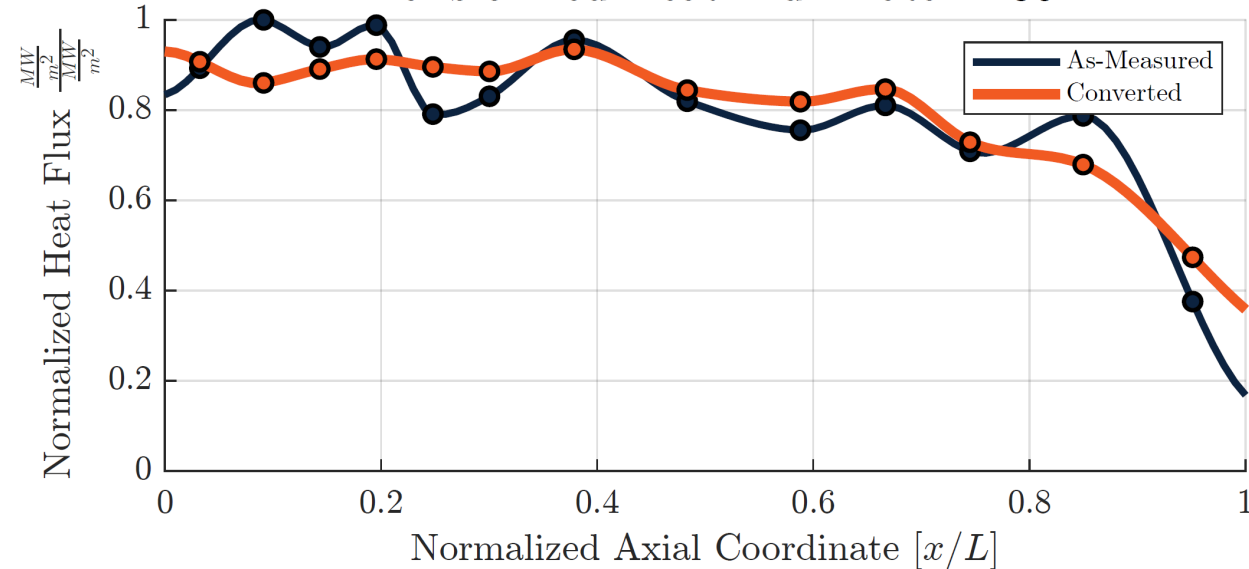

$$H_{cal} = \frac{1}{\zeta} \quad K = \left[1 - \frac{q''_{theo}}{q''_{meas}} \right]$$

$$q''_{theo} = (H_{cal} \cdot K) q''_{meas}$$

Can also be expressed as:

$$(q''_{theo} \cdot \zeta) + q''_{theo} = q''_{meas}$$