

# Lessons Learned and Gaps in Standards Related to Controlling Catastrophic Hazards for Human Spacecraft Propulsion Systems

**6-13-2025**

**Presentation to Industry TIM**

## Public Release Statement

This document has been reviewed for Proprietary, SBU, and Export Control (ITAR/EAR) and has been determined to be non-sensitive. It has been released to the public via the NASA Scientific and Technical Information (STI) Process DAA# 20250004573.

Eric Hurlbert / JSC EP4

John Albright / JSC EP4 Trivector

With inputs from the NASA propulsion community

# Motivation

- Upfront communication and clarity in key standards and requirements that control hazards will improve Flight Safety and Mission Success, save time, and reduce cost overall
  - Uncovering issues late with propulsion systems are a flight safety risk and costly
  - Need to incorporate lessons learned in rationale to explain why a particular requirement is important

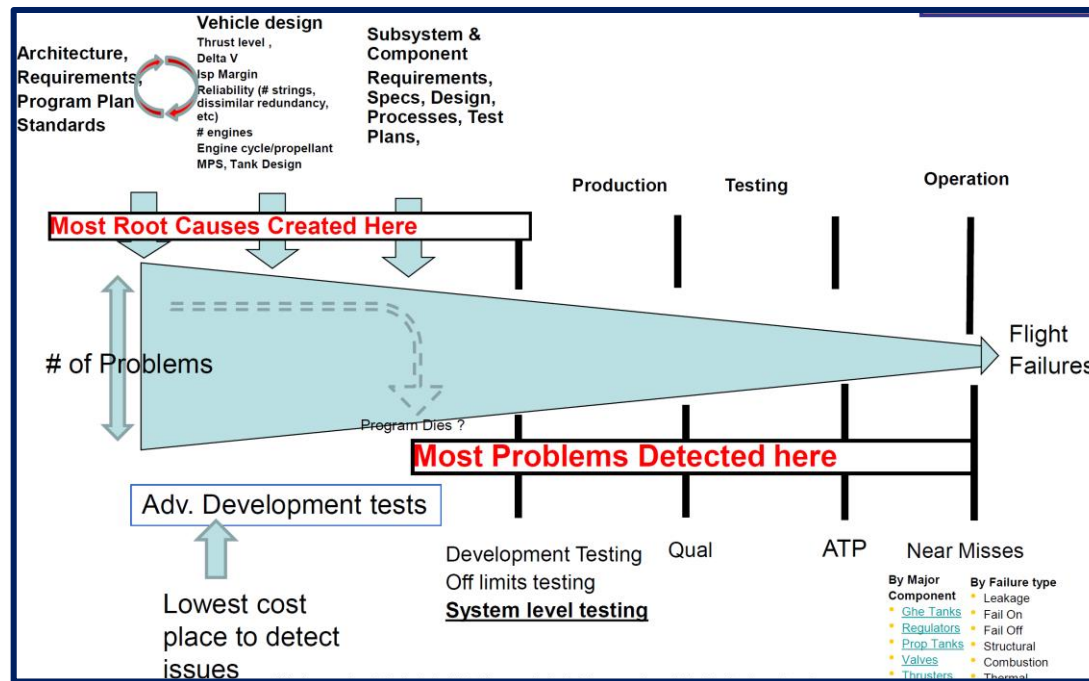

# Overview of the Gap Assessment Process

## NASA-STD-8719.29 NASA Technical Requirements for Human-Rating

- **4.3.1** 1-FT to Catastrophic Events
- **4.3.1.1** Primary Struct and Pressure Vessels exempt to 1 FT if follow Approved Standards..
- **4.3.7** Isolate and Recover from Faults
- **4.3.8** Facilitate anomaly resolution during and after the mission.

Lessons Learned  
Hazard Controls

NASA, Military, Industry  
Standards,  
And Previous Program  
Requirements\*

ANSI/ASAS 5-001	Space Systems - Composite Overwrapped Pressure Vessels	9-2010	Eng	2
EST-STD-02348	Product Classification Levels - Applications, Requirements, and Determination	8	Eng	2
ISO 14644-1	Cleanrooms and Associated Controlled Environments - Part 1: Classification of Air Cleanliness by Particle Concentration - Second Edition	Second Edition, 12/15/2015	Eng	2
JANNAF-01-2002-0001	Guidelines for Combustion Stability Specifications and Verification Procedures for Liquid Propellant Rocket Engines	Jan 1997	Eng	2
JSC-00000-2	JSC Design and Procedural Standards	8 w/ Chg 1	Eng	2
JSC 21596	NASA Standard Industrial Order's Guide	A	Eng	2
JSC-03309	Human Rated Spacecraft Pyrotechnic Specification	8	Eng	2
JSC-04342	Structure Design and Factors of Safety for Spaceflight Hardware	8 w/ Chg 1	Eng	2
JSC-05839	Loads and Structural Dynamics Requirements for Spaceflight Hardware	8	Eng	2
JSC-07095	Best Practices and Guidelines (BPGs) for High Wall Pressure Boundaries (TWPs) for Human Spaceflight Applications	A	Eng	2
MSPC-SPEC-0746	Flow-induced Vibration Assessment Requirements for Metal Bellows and Flex Hoses	8L	Eng	2
NASA-SPEC-0022	NASA Manufacturing and Test Requirements for Normally Closed Pyrovalves for Hazardous Flight Systems Applications	8L w/ Chg 2	Eng	2
NASA-STD-4003	Electrical Bonding for NASA Launch Vehicles, Spacecraft, Payloads, and Flight Equipment	A w/ Chg 1	Eng	2
NASA-STD-5000	Nondestructive Evaluation (NDE) Requirements for Fracture Critical Materials Components	C	Eng	2
NASA-STD-5013	Strength and Life Assessment for Liquid Rocket Engines	B	Eng	2
NASA-STD-5017	Design and Development Requirements for Mechanisms	B	Eng	2
NASA-STD-5020	Fracture Control Requirements for Spaceflight Hardware	A w/ Chg 3	Eng	2
NASA-STD-5020	Requirements for Unmanned Powering Systems in Spaceflight Hardware	A	Eng	2
NASA-STD-6004	Standard Materials and Process Requirements for Spacecraft	C	Eng	2
NASA-STD-7000	Standard for Models and Simulations	A w/ Chg 1	Eng	2
NASA-STD-7012	LAB Test Requirements	A	Eng	2
NASA-STD-7100	Safety Standard for Explosives, Propellants, and Pyrotechnics	A w/ Chg 2	Eng	2
NASA-STD-8719.10	Electrical, Electronic, and Electromechanical (EEE) Parts Assurance Standard	8L	SDMA	2
NEC-RP-19-01468	Filtration of Spaceflight Propulsion and Pressurant Systems	N/A	Eng	2
NEC Technical Bulletin No. 22-02	Revising Filtration Standards and Definitions for Spaceflight Propulsion and Pressurant Systems	N/A	Eng	2
NPR 6000.1	Requirements for Packaging, Handling, and Transportation for Astronautical and Space Systems, Equipment, and Associated Components	H	Eng	2

Page | 13 Internal NASA Distribution Only

**Note:** Many requirements are placed into program requirements (Shuttle, ISS, CCP) over the life of the program and do not exist in other standards.

Gaps

**S** = Standard Requirement Exists but needs to be Type 2 in whole or in part  
**SC** = Standard Exists but needs Clarification for human rating  
**G** = Gaps in Standards

Map to

- Hazards/Failure Modes
- Lessons Learned

STANDARD FOR THE CONTROL OF  
CATASTROPHIC HAZARDS IN HUMAN-  
RATED SPACECRAFT PROPULSION  
SYSTEMS

Abstract

Building safe, reliable, high performance, and successful spacecraft propulsion systems for human spaceflight by appropriate application of the necessary standards, practices, and hazard mitigations early in the design and test phase.



JSC-67723

Compliance is Mandatory

Export Control Notice  
This publication is intended for internal NASA distribution only. Release to the public or foreign entities requires additional approval.

Page | 2

Internal NASA Distribution Only

**Publicly Available**

# Incorporate NASA's Lesson Learned and Technical Bulletins

- Gathered inputs and review comments from many engineers at GRC, MSFC, JSC, etc over the last couple of years
- Read NASA STI Reports on Lessons Learned
  - Public reports written by the responsible engineers across all centers and industry
  - Includes AIAA, etc
- NASA Public Lessons Learned System inputs from all centers
- Public NESC Technical Bulletins and Reports

**NEWS**  
News, features & press releases

**MISSIONS**  
Current, future, past missions & launch dates

**MULTIMEDIA**  
Images, videos, NASA TV & more

**CONNECT**  
Social Media Channels & NASA Apps

**ABOUT NASA**  
Leadership, organization, budget, careers & more

Home | For Public | For Educators | For Students | For Media

Enter Search Term

### Overview

**Welcome to the NASA Public Lessons Learned System!**  
The NASA Lessons Learned system provides access to official, reviewed lessons learned from NASA programs and projects. These lessons have been made available to the public by the NASA Office of the Chief Engineer and the NASA Engineering Network. Each lesson describes the original driving event and provides recommendations that feed into NASA's continual improvement via training, best practices, policies, and procedures.

**NOTE:** If you are a NASA user, you may access the internal site on the [NASA Engineering Network](#) to view and share lessons.

**To search the NASA Lessons Learned database system:**  
Click on one of the search options in the left navigation bar. Once you click, you will also have access to refine your search, using more advanced search features.

If you are a NASA employee, you may [submit a NASA Lessons Learned](#) from here.

NEN is sponsored by the [NASA Office of the Chief Engineer](#).

#### NASA Centers

<a href="#">Ames Research Center</a>	119
<a href="#">Armstrong Flight Research Center</a>	30
<a href="#">Glenn Research Center</a>	116
<a href="#">Goddard Space Flight Center</a>	145
<a href="#">Jet Propulsion Laboratory</a>	422
<a href="#">Johnson Space Center</a>	236
<a href="#">Kennedy Space Center</a>	483
<a href="#">Langley Research Center</a>	101
<a href="#">Marshall Space Flight Center</a>	201
<a href="#">NASA Engineering &amp; Safety Center</a>	30
<a href="#">NASA Headquarters</a>	206
<a href="#">NASA IVV</a>	1
<a href="#">Stennis Space Center</a>	17
<a href="#">Wallops Flight Facility</a>	1
<a href="#">White Sands Test Facility</a>	13

# Scope of Human Rated Spacecraft Propulsion Standard

- **Address Existing and New Spacecraft Propellants**
  - Hydrazine
  - Hypergolic Liquid Bipropellant (MMH/NTO)
  - Gaseous Oxygen, Gaseous Methane , Gaseous Hydrogen ,
  - Hydrogen Peroxide / Kerosene
  - Cryogenics; such as Lox, LCH4, LH2
  - Other propellants that are in work also have a path
    - I.e., Green propellants
- **New Capabilities or configurations**
  - Integrated High Thrust Liquid Abort systems and engines
  - Pump-fed systems
- **Exceptions to scope of document**
  - Does Not Include Electric Propulsion Thruster, however Xenon fluid system would be encompassed by requirements
  - Does not include cryocooler requirements

# Table 1 Human-Rated Spacecraft with Flight History

PROJECT/PROGRAM	ELEMENT/VEHICLE/PAYLOAD	PROPULSION SYSTEM DETAILS		STATUS
		PROPELLANT(S)	VACUUM THRUST LEVEL(S)	
MERCURY	SPACECRAFT CAPSULE	90% H2O2	1 LBF, 6 LBF, 24 LBF (REF) (NASA, 1963, PP. 54,283)	FLOWN
GEMINI	CAPSULE ORBIT ATTITUDE AND MANEUVERING SYSTEM (OAMS) AND REACTION CONTROL SYSTEM (RCS)	MMH / NTO	8 X 25 LBF OAMS 8 X 100 LBF OAMS 16 X 25 LBF RCS (REF) (BLATZ, 1964, PP. 14, FIG 13)	FLOWN
APOLLO	LUNAR MODULE (LM)	A50 / NTO	10500 LBF (DME) (REF) (HAMMOCK, 1973, P. 7)	FLOWN
APOLLO	LUNAR MODULE (LM)	A50 / NTO	1 X 3500 LBF (AME) (REF) (HUMPHRIES, 1973, P. 2) 16 X 100 LBF (RCS) (REF) (VAUGHAN, 1972, P. 2)	FLOWN
APOLLO	SERVICE MODULE RCS	MMH / NTO	SM: 16X 100 LBF (REF) (TAEUBER, 1973, PP. 6, PARA. 4)	FLOWN
APOLLO	COMMAND MODULE (CM) RCS	MMH / NTO	CM: 12X 100 LBF (REF) (TAEUBER, 1973, PP. 9,39, FIG. 18)	FLOWN
APOLLO	SERVICE MODULE (SM) MAIN ENGINE	A50 / NTO	21,500 LBF (SME) (REF) (GIBSON C. R., 1973, PP. 5, PARA 3)	FLOWN
SSP	ORBITER MAIN PROPULSION SYSTEM (MPS)	LH2 / LO2	3 X 512,000 LBF (REF) (MARTINEZ, 2011, P. 2), SSME RS25	FLOWN
SSP	ORBITER ORBITAL MANEUVERING SYSTEM (OMS)	MMH / MON3	2 X 6000 LBF (REF) (GIBSON C. , 1985, PP. 13, FIG 10)	FLOWN
SSP	ORBITER REACTION CONTROL SYSTEM (RCS)	MMH / MON3	38 X 870 LBF, 6 X 25 LBF (VERNIER) (PRIMARY) (REF) (HERNANDEZ, 2011, PP. 23, PARA 2)	FLOWN
GEMINI, APOLLO, SSP	LO2/LH2 POWER REACTANT STORAGE AND DISTRIBUTION (PRSD) SYSTEM	LOX/LH2 (SUPERCRITICAL)	UP TO 3 X UP TO 16 KW (REF) (HERNANDEZ, 2011, P. 28), (REF) (DAVIS, 1970), (REF) (SIMON, 1985, PP. 15, TABLE 3),	FLOWN
ORION MPCV	CREW MODULE (CM)	HYDRAZINE	12 X 160 LBF (REF)	FLOWN
ORION MPCV	SERVICE MODULE (SM)	MMH / MON3	1 X 6225 LBF (27.7 KN) (OMS-E) 8 X 110 LBF (490N) (AUX) 24 X 50 LBF (220N) (RCS) (REF) (PHILIPPE BERTHE, 2017, PP. 4-5)	FLOWN
ISS	SOYUZ ON-ORBIT	UDMH / N2O4	28 X 30 LBF (REF) (BOWMAN, 2016, P. 6:07)	FLOWN
ISS	SOYUZ DESCENT MODULE (DM)	H2O2	8 SMALL THRUSTERS (REF) (NASA PRESS KIT, 2004, P. PARA 6)	FLOWN
ISS CRS	H-II TRANSFER VEHICLE (HTV)	MMH / MON3	4 X 110 LBF MAIN 28 X 25 LBF ACS (REF) (MATSUO, 2012, PP. 1-2)	FLOWN

PROJECT/PROGRAM	ELEMENT/VEHICLE/PAYLOAD	PROPULSION SYSTEM DETAILS		STATUS
		PROPELLANT(S)	VACUUM THRUST LEVEL(S)	
ISS CRS	AUTOMATED TRANSFER VEHICLE (ATV)	MMH / MON3	4 X 110 LBF MAIN 28 X 50 LBF ACS (REF) (EUROPEAN SPACE AGENCY, N.D.)	FLOWN
ISS CRS	CYGNUS	HYDRAZINE (N2H4) / MON3	DUAL MODE N2H4 AND MON3 OR N2H4 (REF) (GRUMMAN, N.D.)	FLOWN
ISS CCP / CRS	DRAGON	MMH / MON3	8 X 16K LBF LIQUID ABORT 16 X 90 LBF DRACO (REF) (SPACEX, N.D.)	FLOWN
ISS CCP	CST-100 STARLINER	MMH / MON3	4X 40K LBF LIQUID ABORT, 20 X 1500 LBF ORBITAL, 28 X 85 LBF RCS (REF) (L3HARRIS, N.D.)	FLOWN

- Note: HTV, ATV & Cygnus meet ISS safety req'ts for interfacing with a human rated spacecraft

These are examples of human-rated spacecraft prop systems that form the basis of collective NASA/industry experience

# JSC 67723 Human Rated Spacecraft Propulsion Standard

- **Most of the JSC-67723 requirements are margins, inspections, fault detection capability, or test requirements that address a cause for catastrophic hazard**
  - The word “shall” is used as it is derived from the need to control catastrophic hazards
    - In many cases we elevate guideline document that say “should” to “shall”
    - The words “in best practice” or “should” may appear in the Guidance/Rationale
  - “Shall”s are contained in the JSC-67723 document with the intent that this is a Type 2 document or requirement
    - **Type 2** = “shall” standard or requirement
    - **Type 3** = “reference or guideline”
- **Tailoring**
  - Tailoring of this NASA Technical Standard for application to a specific program or project shall be formally documented as part of program or project requirements and approved by the responsible Technical Authority in accordance with NPR 7120.5, NASA Space Flight Program and Project Management Requirements.
  - A Tailoring Matrix in Excel Format will be provided
  - If document is levied as a Type 3, then “shalls” become “should in best practice”, except for those requirements specifically called out as Type 2 or in program requirement documents.
- **Alternate Standard or Design Approach**
  - In some situations, an alternate or design approach may satisfy the intent of the JSC-67723 requirement for controlling the hazard
  - JSC-67723 is not intended to eliminate design approaches that meet the intent
    - Verification of the alternate requirement or design approach shall include test or inspection
- **Industry Review**
  - This review process is intended to gather industry as well as additional NASA feedback

Purpose of the Industry TIM is to get some specific feedback on individual requirements

# Type 2 Standards called out by JSC-67723

Document #	Document Title	Rev	TA	Type	Public
A-A-59150	Cleaning Compound, Solvent, Hydrofluoroether (HFE)	A, 02/14/2003	Eng	2	Y
AIA/NAS412	Foreign Object Debris (FOD) Prevention Guidance Document	3, 2023	Eng	2	Y
AIAA G-082	Guide: Space Systems – Composite Overwrapped Pressure Vessels with a Plastic Liner	2022	Eng	2	Y
AIAA SP-084-1999	Fire, Explosion, Compatibility, and Safety Hazards of Hypergols – Hydrazine	1999 w/ 12/05/2001 Correction	Eng	2	Y
AIAA SP-085-1999	Fire, Explosion, Compatibility, and Safety Hazards of Hypergols – Monomethylhydrazine	1999	Eng	2	Y
AIAA SP-086-2001	Fire, Explosion, Compatibility, and Safety Hazards of Nitrogen Tetroxide	Jan 2001	Eng	2	Y
AFRL-RZ-ED-TP-2008-184	Nitrous Oxide Explosive Hazards	05/19/2008	Eng	2	Y
ANSI/AIAA G-095	Guide to Safety of Hydrogen and Hydrogen Systems	A-2017	Eng	2	Y
ANSI/AIAA S-080	Space Systems - Metallic Pressure Vessels, Pressurized Structures and Pressurized Components	A-2018	Eng	2	Y
ANSI/AIAA S-081	Space Systems - Composite Overwrapped Pressure Vessels	B-2018	Eng	2	Y
AIAA-S-157	In Space Storable Fluid Transfer for Prepared Spacecraft	-2024	Eng	2	Y
ARP901	Bubble-Point Test Method	Rev B	Eng	2	Y
ARP599	Aerospace - Dynamic Test Method for Determining the Relative Degree of Cleanliness of the Downstream Side of Filter Elements	Rev D	Eng	2	Y
ASTM D1193	Standard Specification for Reagent Water	11/1/2024	Eng	2	Y
ASTM MNL 36	Safe Use of Oxygen and Oxygen Systems: Guidelines for Oxygen System Design, Materials Selection, Operations, Storage, and Transportation	Second Edition	Eng	2	Y
CGA G-8.2	Commodity Specification for Nitrous Oxide	Seventh Edition	Eng	2	Y
CGA G-11.1	Commodity Specification for Argon	Eighth Edition	Eng	2	Y
IEST-STD-CC1246	Product Cleanliness Levels – Applications, Requirements, and Determination	E, Feb 2013	Eng	2	Y
ISO 14644-1	Cleanrooms and Associated Controlled Environments – Part 1: Classification of Air Cleanliness by Particle Concentration - Second Edition	Second Edition, 12/15/2015	Eng	2	Y
JANNAF-GL-2022-0001 (Note: Formerly CIA 655)	Guidelines for Combustion Stability Specifications and Verification Procedures for Liquid Propellant Rocket Engines	Jan 1997	Eng	2	N
JSC-08080-2	JSC Design and Procedural Standards	B w/ DCN 001, 08/04/2020	Eng	2	Y
JSC 28596	NASA Standard Initiator User's Guide	A, 02/29/2000	Eng	2	N

Document #	Document Title	Rev	TA	Type	Public
JSC 62809	Human Rated Spacecraft Pyrotechnic Specification	G, 11/08/2024	Eng	2	N
JSC 65828	Structural Design and Factors of Safety for Spaceflight Hardware	B w/ Chg 1, 07/15/2014	Eng	2	Y
JSC 65829	Loads and Structural Dynamics Requirements for Spaceflight Hardware	B, 03/01/2024	Eng	2	Y
JSC 67035	Best Practices and Guidelines (BP&G) for Thin Wall Pressure Boundaries (TWPB) for Human Spaceflight Applications	A, Aug 2017	Eng	2	Y
JSC ES 151001-1	Use of ASME Code or Code of Federal Regulations Title 49 Department of Transportation (DOT) Pressure Vessels for Space Applications	01/19/2016	Eng	2	N
MIL-PRF-27401	Performance Specification, Propellant Pressurizing Agent, Nitrogen	H w/ Amd 2, 01/09/2024	Eng	2	Y
MIL-PRF-27407	Performance Specification, Propellant Pressurizing Agent, Helium	E, 04/23/2024	Eng	2	Y
MIL-PRF-26536	Performance Specification, Propellant, Hydrazine	G w/ Amd 1, 07/13/2021	Eng	2	Y
MIL-PRF-16005	Performance Specification, Propellant, Hydrogen Peroxide	F, 08/01/2023	Eng	2	Y
MIL-PRF-27201	Performance Specification, Propellant, Hydrogen	F, 08/26/2022	Eng	2	Y
MIL-PRF-25508	Performance Specification, Propellant, Oxygen	J, 03/02/2020	Eng	2	Y
MIL-PRF-26539	Performance Specification, Propellant, Dinitrogen Tetroxide	G w/ Amd 1, 04/19/2017	Eng	2	Y
MIL-PRF-27404	Performance Specification, Propellant, Monomethylhydrazine	D, 04/20/2012	Eng	2	Y
MIL-PRF-27415	Propellant Pressurizing Agent, Argon	D, 02/28/2023	Eng	2	Y
MIL-PRF-32207	Performance Specification, Propellant, Methane	BL, 10/10/2006	Eng	2	Y
MIL-PRF-25567	Leak Detection Compound, Oxygen Systems	E, 07/10/2015	Eng	2	Y
MIL-STD-461	Requirements for the Control of Electromagnetic Interference Characteristics of Subsystems and Equipment	G, 12/11/2015	Eng	2	Y
MIL-DTL-25576	Detail Specification, Propellant, Rocket Grade Kerosene	F w/ Amd 1, 05/24/2023	Eng	2	Y
MSFC-SPEC-3746	Flow-Induced Vibration Assessment Requirements for Metal Bellows and Flex hoses	BL, 04/16/2020	Eng	2	Y
NASA-SPEC-5022	NASA Manufacturing and Test Requirements for Normally Closed Pyrovalves for Hazardous Flight Systems Applications	BL w/ Chg 2, 06/24/2015	Eng	2	Y
NASA-STD-4003	Electrical Bonding for NASA Launch Vehicles, Spacecraft, Payloads, and Flight Equipment	A w/ Chg 1, 01/16/2019	Eng	2	Y

# Type 2 Standards called out by JSC-67723 (cont.)

Document #	Document Title	Rev	TA	Type	Public
NASA-STD-5009	Nondestructive Evaluation (NDE) Requirements for Fracture Critical Metallic Components	C, 08/03/2023	Eng	2	Y
NASA-STD-5012	Strength and Life Assessment for Liquid Rocket Engines	B, 06/16/2016	Eng	2	Y
NASA-STD-5017	Design and Development Requirements for Mechanisms	B, 12/06/2022	Eng	2	Y
NASA-STD-5019	Fracture Control Requirements for Spaceflight Hardware	A w/ Chg 4, 02/01/2016	Eng	2	Y
NASA-STD-5020	Requirements for Threaded Fastening Systems in Spaceflight Hardware	B, 08/06/2021	Eng	2	Y
NASA-STD-6016	Standard Materials and Processes Requirements for Spacecraft	C w/ Chg 1, 11/15/2023	Eng	2	Y
NASA-STD-7009	Standard for Models and Simulations	A, 05/08/2019	Eng	2	Y
NASA-STD-7012	Leak Test Requirements	A, 02/22/2023	Eng	2	Y
NASA-STD-8719.12	Safety Standard for Explosives, Propellants, and Pyrotechnics	A w/ Chg 2, 03/18/2021	Eng	2	Y
NASA-STD-8719.24 and Annex	ANNEX TO NASA-STD-8719.24, NASA Payload Safety Requirements: Requirements Table	B, 03/30/2022	S&MA	2, In part	Y
NASA-STD-8719.29	NASA Technical Requirements for Human Rating	BL, 12/11/2023	S&MA	2	Y
NASA-STD-8739.10	Electrical, Electronic, and Electromechanical (EEE) Parts Assurance Standard	BL, 06/17/2013	S&MA	2	Y
NASA/TM-20210022275	Treatment of Transient Pressure Events in Space Flight Pressurized Systems	N/A	Eng	2	Y
NESC-RP-19-01498	Filtration of Spaceflight Propulsion and Pressurant Systems	N/A	Eng	2	Y
NESC Technical Bulletin No. 22-02	Revisiting Filtration Standards and Definitions for Spaceflight Propulsion and Pressurant Systems	N/A	Eng	2	Y
NPR 6000.1	Requirements for Packaging, Handling, and Transportation for Aeronautical and Space Systems, Equipment, and Associated Components	H	Eng	2	Y
NPR 8705.2	Human-Rating Requirements for Space Systems	C w/ Chg 2	N/A	N/A	Y
MIL-STD-1252	Inertia Friction Welding Process, Procedure and Performance Qualification	BL,03/11/1998	Eng	2	Y
SMC-S-016	Test Requirements for Launch, Upper-Stage, and Space Vehicles	09/05/2014	Eng	2	Y
SMC-S-025	Evaluation and Test Requirements for Liquid Rocket Engines	07/26/2017	Eng	2	Y
TOR-2013(3909)-1	Objective Reuse of Heritage Products	04/30/2012	Eng	2	Y
TT-I-735	Isopropyl Alcohol	A, 06/06/2007	Eng	2	Y

# Type 3 Reference Guidelines

Document #	Document Title	Rev	TA	Type	Public
AIAA 91-2172	Propellant Management Device Conceptual Design and Analysis: Vanes	1991	Eng	3	Y
AIAA 93-1970	Propellant Management Device Conceptual Design and Analysis: Sponges	1993	Eng	3	Y
AIAA 97-2811	Propellant Management Device Conceptual Design and Analysis: Galleries	1997	Eng	3	Y
AFRPL-TR-69-149	USAF Propellant Handbook Hydrazine Fuels Vol I	March 1970	Eng	3	Y
AFRPL-TR-76-76	USAF Propellant Handbook Nitric Acid/Nitrogen Tetroxide Oxidizers	Feb. 1977	Eng	3	Y
ANSI/AIAA S-120	Mass Properties Control for Space Systems	A-2015	Eng	3	Y
ARAED CR-90002	Hazard Classification Testing of Liquid Propellants	May 1990	Eng	3	Y
CGA G-5.3	Commodity Specification for Hydrogen	8 <sup>th</sup> Edition, 2024	Eng	3	Y
FED-STD-209	Airborne Particulate Cleanliness Classes in Cleanrooms and Clean Zones	E, 09/11/1992 (cancelled 11/29/2001)	Eng	3	Y
JANNAF CPIA Publication 246	Rocket Engine Performance Prediction and Evaluation Manual	April 1975	Eng	3	Y
KSC-STD-Z-0006	Design of Hypergolic Propellants Ground Support Equipment, Standard For,	C	Eng	3	Y
NASA-HDBK-4007	Spacecraft High Voltage Paschen and Corona Design Handbook.	Change 3, 2020-12-29	Eng	3	Y
NASA-HDBK-5010	Fracture Control Implementation Handbook for Payloads, Experiments, and Similar Hardware, Vol I and II	Vol I: A, 12/15/2023 Vol II: A, 01/09/2024	Eng	3	Y
NASA-HDBK-5013	Pyrovalve Applications and Performance Handbook	A w/ Chg 2, 12/27/2021	Eng	3	N
NASA-HDBK-7009	NASA Handbook for Models and Simulations: An Implementation Guide for NASA-STD-7009A	A, 05/08/2019	Eng	3	Y
NASA-HDBK-8739.19-2	Measuring and Test Equipment Specifications.	2010-07-13 Baseline	S&MA	3	Y
NASA-HDBK-8739.19-3	Measurement Uncertainty Analysis Principles and Methods, NASA Measurement Quality Assurance Handbook - ANNEX 3	2010-07-13 Baseline	S&MA	3	Y
NASA SP-8055	Prevention of Coupled Structure-Propulsion Instability (POGO)	Oct 1970	Eng	3	Y
NASA-STD-6001	NASA-STD-6001, Flammability, Offgassing, and Compatibility Requirements and Test Procedures.	B w/ Chg 2, 04/21/2016	Eng	3	
NASA/TM-20210022275	Treatment of Transient Pressure Events in Space Flight Pressurized Systems	Oct 2021	Eng	3	Y
NASA TN D-6349	Fundamental Techniques of Weight Estimating and Forecasting for Advanced Manned Spacecraft and Space Stations	May 1971	Eng	3	Y
NESC Technical Bulletin 19-02	90/95 POD Radiography Concern for COPVs and Metal Tank Welds	N/A	Eng	3	Y

Document #	Document Title	Rev	TA	Type	Public
NESC Technical Bulletin 20-06	Material Compatibility Assessment of Spacecraft Oxidizer Systems	N/A	Eng	3	Y
NESC Technical Bulletin 20-07	Evaluating and Mitigating Liner Strain Spikes in COPVs	N/A	Eng	3	Y
NESC Technical Bulletin 21-01	Experimental and Computational Study of Cavitation in Hydrogen Peroxide	N/A	Eng	3	Y
NESC Technical Bulletin 22-03	Treatment of Transient Pressure Events in Space Flight Pressurized Systems	N/A	Eng	3	Y
NESC Technical Bulletin 22-07	Helium Solubility in MMH and NTO	N/A	Eng	3	Y
NESC Technical Bulletin 22-08	Contamination Reduction in High Purity Hydrazine	N/A	Eng	3	Y
SAE AS85421	Fittings, Tube, Fluid Systems, Separable, Beam Seal, 3000-4000 psi, General Specification for	C, May 2021	Eng	3	Y

# Example Requirements – Identifying Gaps and Lessons Learned

**S** = Standard Exists but needs to be Type 2 in whole or in part  
**SC** = Standard Exists but needs Clarification or Augmentation  
**G** = Gaps in the Standard or Requirement

## 3.7.3 Control of Corrosive and Reactive Propellant Liquid and Vapors in the Pressurization System

3.7.3.1 *The unintended mixing of liquid and/or vapor-phase hypergolic fuel and oxidizer in a human rated spacecraft propulsion system shall be controlled via compliance with the 'separation of hypergolic reactants' requirements of paragraph F-15 in JSC-08080-2, JSC Design and Procedural Requirements. [PSR-203S]*

Rationale: The content of paragraph F-15 (Separation of liquid and/or vapor-phase hypergolic reactants) is a useful containment approach throughout a spacecraft propulsion system, except for the intentional mixing of those fluids in the combustion chamber of a firing engine/thruster.

3.7.3.2 *Check valves, vapor isolation valves, tank elastomeric diaphragms/bladders, and tank liquid retention devices shall be precluded from consideration as effective means of preventing propellant vapor migration upstream into the pressurization system, thereby requiring material compatibility and component exposure tests of pressurization system hardware per NASA-STD-6016 and herein. [PSR-204SC]*

Rationale: Past experience has clearly demonstrated that check valve seats, tank elastomeric diaphragms/bladders, etc. can migrate upstream into the pressurization system, resulting in corrosion or other reactions in the case of monopropellants that can result in catastrophic hazards.

3.7.3.3 *The condensation of propellant vapors in the pressurization system and components shall be controlled to preclude material reactions, corrosion, clogging, and excessive transient pressures during system operation, leading to component failures which can create a catastrophic hazard. [PSR-205G]*

Rationale: Temperature gradients, propellant vapor that has migrated into the upstream pressurization system to condense in the components and lines, resulting in reactions, corrosion, clogging, and/or excessive transient pressures above MDP during system operation, which can result in hardware failure leading to a catastrophic hazard.

3.7.3.4 *The use of a common pressurization system in a spacecraft bipropellant propulsion system shall be limited to situations where the migration and mixing of fuel and oxidizer (liquid or vapor) is prevented by pyro valve separation or other means to inhibit the reaction, then followed by short term use or engine burn and disposal with the stipulation that this other means has been verified by system level tests for 2x the maximum potential exposure duration. [PSR-206G]*

Rationale: Short duration (i.e. hours-days ) mission vehicles have been successful, however catastrophic failure has been observed at longer durations possibly due to higher than expected permeation, leakage, or thermal conditions that allow the collection and condensation of propellant vapor, resulting in the possible mixing of fuel and oxidizer to create a catastrophic hazard. This was most probable cause of failure for the Mars Observer spacecraft, reference (LLIS-485) Isolate the Propulsion Pressurization System from the Propellant Tanks (LLIS-485, 1996) , and involved with other in-flight anomalies such as the Juno Spacecraft, reference (LLIS-28105) High Oxidizer Vapor Content May Cause Vapor Reaction in Bi-Propellant Systems. (LLIS-28105, 2017)

**S = Existing Standard**

**SC = Clarification to Existing Standard**

**G = Requirement that address a gap in an Existing Standard**

Lesson Learned Links

# Appendix A: Tailoring Matrix

This Appendix provides a listing of requirements contained in this NASA Technical Standard for selection and verification of requirements by programs and projects. (**Note:** Enter “Yes” to describe the requirement’s applicability to the program or project; enter “Tailored” if the intent is to tailor or enter “No” for not applicable. Enter rationale for “Tailoring” or “No” in the “Rationale” column.)

Section	Section Title and Requirement Topic or Synopsis	Requirement in this Standard	Applicable (Yes, Tailored or No)	If Tailored or No, Enter Rationale
3.1	<b>Vehicle and Propulsion System Requirements</b>			
3.1.1	<b>Vehicle and Propulsion System Performance</b>			
3.1.1.1	Mission Critical Propulsion Performance Parameters	[PSR-01G]		
3.1.1.2	Design Specification Natural Environment SLS-SPEC-159	[PSR-02S]		
3.1.2	<b>Critical Math Models</b>			
3.1.2.1	NASA-STD-7009	[PSR-03S]		
3.1.2.2	Performance, MDP, Thermal, GNC, Slosh, Pogo, Power Models, etc.	[PSR-04G]		
3.1.3	<b>Reusable Vehicle Propulsion Systems</b>			
3.1.3.1	Reusable Vehicle Service Life	[PSR-05SC]		
3.1.3.2	JSC-08080-2B a. G-1, Maintainability, b. G-52 Reuse	[PSR-06S]		
3.1.3.3	Operation and Maintenance Requirements and Specification	[PSR-07G]		
3.1.4	<b>Redundancy and Fault Tolerance</b>			
3.1.4.1	Section 4.3 of NASA-STD-8719.29, NASA Tech. Req. for Human Rating	[PSR-08S]		
3.1.4.2	Assess catastrophic hazards that results from 2 faults	[PSR-09G]		
3.1.4.3	JSC-08080 G-8 Design for Redundancy Verification	[PSR-10S]		
3.1.5	<b>Failure Tolerance Exceptions in Propulsion Systems</b>			
3.1.5.1	Failure Tolerance Exceptions (or DFMR)	[PSR-11SC]		
3.1.6	<b>Separation or Protection of Redundant Functions</b>			
3.1.6.1	JSC-08080 G-2 Separation of Redundant Systems	[PSR-12S]		
3.1.7	<b>GN&amp;C and Thrusters/Engine Performance and Service Life ICD</b>			
3.1.7.1	Attitude control	[PSR-13G]		
3.1.7.2	Delta-V translational	[PSR-14G]		
3.1.7.3	Evaluation of Engine Options at SDR against GNC requirements	[PSR-15G]		

# JSC 67723 Spacecraft Propulsion System Standard

## 3.1 Vehicle-to-Propulsion

- 3.1.1 Vehicle Performance
- 3.1.2 Critical Math Models
- 3.1.3 Reusable Prop Systems
- 3.1.4 Redundancy Fault Tolerance
- 3.1.5 Fault Tolerance Exceptions DFMR
- 3.1.6 Protection of Redundant Functions
- 3.1.7 GNC to Thruster
- 3.1.8 Plume Impingement
- 3.1.9 Slosh
- 3.1.10 Differential Draining, C.G.
- 3.1.10 Load and Dynamics
- 3.1.12 POGO – Thrust/Structural
- 3.1.13 Thermal
- 3.1.14 Vents
- 3.1.15 Problem Resolution

## 3.2 Propulsion System & Component Testing (SMC-S-016)

- 3.2.1 General Tests
- 3.2.2 System Qual
- 3.2.3 System development tests
- 3.2.4 Propulsion System Acceptance, AI&T
- 3.2.5 Leakage Measurement

## 3.3 Pressurant and Propellants

- 3.3.1 General Fluid Proc and Usage
- 3.3.2 Interface, Sampling
- 3.3.3 Pressurants, Cold Gas
- 3.3.4 Monopropellants,
- 3.3.5 Monopropellant hazards
- 3.3.6 Bipropellants
- 3.3.7 Earth Storable hazards
- 3.3.8 Cryogenic hazards
- 3.3.9 Fluid Property Traceability

## 3.4 M&P , Fluid Compatibility

- 3.4.1 M&P NASA-STD-6016
- 3.4.2 Assembly, Cleaning Fluids
- 3.4.3 Material Compatibility and Tests
- 3.4.4 Oxidizer Compatibility Assessments
- 3.4.5 Softgoods
- 3.4.6 Contamination Control
- 3.4.7 FOD, Air, Moisture Intrusion Control
- 3.4.8 Welding and Bimetallic Joints

## 3.5 General Pressurized (MDP)

- 3.5.1 MDP
- 3.5.2 Fracture
- 3.5.3 NDE
- 3.5.4 Threaded Fasteners

## 3.6 Pressure Vessels and Propellant Tanks

- 3.6.1 Integrated Pressure vessels
- 3.6.2 Metallic Pressure Vessels
- 3.6.3 COPV
- 3.6.4 Composite with plastic liner
- 3.6.5 Type V all composite
- 3.6.6 Liquid PMD
- 3.6.7 Slosh
- 3.6.8 Gauging and Un-usables

## 3.7 Pressure Relief and Regulation

- 3.7.1 Pressure Reg System
- 3.7.2 Overpressure Protection
- 3.7.3 Reactive Vapors

## 3.8 General Valve Requirements

- 3.8.1 General (5017, etc)
- 3.8.2 Tolerance stackup analysis
- 3.8.3 Torque/Force Margin Tests
- 3.8.4 Cycle Life
- 3.8.5 Valve electrical

## 3.9 Propellant Feed system

- 3.9.1 Engine Interface
- 3.9.2 Feed-system Activation
- 3.9.3 Feedsystem MDP
- 3.9.4 Feed system model V&V
- 3.9.5 Inhibits to Bulk Prop Leakage
- 3.9.6 Backpressure Relief
- 3.9.7 Fluid Line Materials, Routing, etc

## 3.10 Mechanical Fittings and Flanges

- 3.10.1 Use of Fitting vs. Weld
- 3.10.2 1FT Design, Qual, Acceptance

## 3.11 In-space Fluid Transfer and Modules

- 3.11.1 In-Space Transfer
- 3.11.2 Separation of Spacecraft

## 3.12 Filters and Filtration

- 3.12.1 Identification of Sources
- 3.12.2 Sensitivity to Contamination
- 3.12.3 Filter Locations
- 3.12.4 Filter Spec, Qual, ATP
- 3.12.5 Alternate to Wire Cloth/Etched Disc

## 3.13 Pyrotechnic Valves

- 3.13.1 Type NC vs NO requirements
- 3.13.2 General and Propulsion Specific Requirements

## 3.14 TWFPB

- 3.14.1 TWFPB Failure Modes
- 3.14.2 TWFPB JSC-67035
- 3.14.3 Flow Induced Vibration

## 3.15 Spacecraft Engines

- 3.15.1 Heritage Evaluation
- 3.15.2 Strength and Life - 5012
- 3.15.3 Reusable Engines
- 3.15.4 Test Requirements SMC-S-025
- 3.15.5 Delta-Qualification
- 3.15.6 Combustion Stability
- 3.15.7 Thermal Management
- 3.15.8 Ignition Systems
- 3.15.9 Control of Hardstarts, Zots, etc
- 3.15.10 Engine Leak Detection
- 3.15.11 TVC

## 3.16 Software, FDIR, Instrumentation/Data

- 3.16.1 FDIR
- 3.16.2 Data Rates
- 3.16.3 System Leak Detection
- 3.16.4 Instrumentation Types

## 3.17 Electrical

- 3.17.1 Electrical Bonding
- 3.17.2 Powered Device Switching

## 3.18 Flight and Ground Interface

- 3.18.1 Time and Cycle Tracking
- 3.18.2 Data Needs for Flight Ops
- 3.18.2 Flight to Ground Interface
- 3.18.3 Hardware Warnings/Markings

## 3.1 Vehicle-to-Propulsion

### 3.1.1 Vehicle and Performance Models

[PSR-01G] = Specify mission critical propulsion system critical performance parameters

[PSR-02S] = Specify Environments SLS-SPEC-159

### 3.1.2 Critical Math Models

[PSR-03S] = Critical models must meet NASA-STD 7009

[PSR-04G] = Define which propulsion system models are critical models; Performance, Maximum Design

### 3.1.3 Reusable Vehicle

[PSR-05SC] = Qualification for repeated inflight and turnaround exposures (ref SMC-S-016 Section 3.4)

[PSR-06S] = JSC080802B G-1, G-52, - Accessibility, Time/Cycle Critical Controls, Reuse of flight hardware

[PSR-07G] = Operations and Maintenance Requirements and Specification Document

### 3.1.4 Redundancy and Fault Tolerance

[PSR-08S] = NASA-STD-8719.29, NASA Technical Requirements for Human Rating (1 FT)

[PSR-09G] = Identify 2<sup>nd</sup> failures needed to cause catastrophic hazard.

[PSR-10S] = JSC080802B G-8 Design for Redundancy Verification

### 3.1.5 Failure Tolerance Exceptions (aka DFMR)

[PSR-11SC] = Section 4.3 of NASA-STD-8719.29, NASA Tech. Req. for Human Rating

### 3.1.6 Separation or Protection of Redundant Functions

[PSR-12S] = JSC080802b – G-2 Separation of Redundant Functions

### 3.1.7 GNC to Propulsion

[PSR-13G] = GNC Attitude Control and Thruster Performance and Service Life requirements definition

[PSR-14G] = GNC Delta-V Engine (DVE) requirements definition (includes integrated Spacecraft liquid abo

[PSR-15G] = Evaluation of Engine Options at SDR against GNC requirements

### 3.1.8 Plume Impingement Loads, Dynamics, Heating, and Contamination

[PSR-16S] = JSC65829 LD22,66,67,68, 69 Plume Impingement Loads and Dynamics

[PSR-17G] = shall be analyzed, designed, tested, and operated to ensure that project/program-defined lim

[PSR-18G] = shall evaluate plume heating of sensitive surfaces

[PSR-19G] = shall evaluate plume impingement and ingestion into sensitive areas (ie parachute cavities, d

### 3.1.9 Slosh Coupling

[PSR-20SC] = JSC65829 Section 6.6 Slosh Coupling + Impact on liquid acquisition, gauging

[PSR-21G] = GNC Control Slosh Requirement such Angular Momentum or Damping

[PSR-22G] = Slosh Feature to damp coupled slosh/swirl in vehicles with multiple tanks

### 3.1.7 GNC-to-Propulsion

- Delta V and RCS Engine Trades:
  - 1) Gimballed Delta-V engine
  - 2) Off-pulsing/Throttling DVE
  - 3) RCS control of fixed DVE
  - 4) RCS maneuvering and control
- Trade drives RCS Duty Cycle, Min/Max EPW, Profile Duration, Thrust level, etc
- Need these defined to select engine and identify design/qual test gaps

### 3.1.9 Slosh Coupling

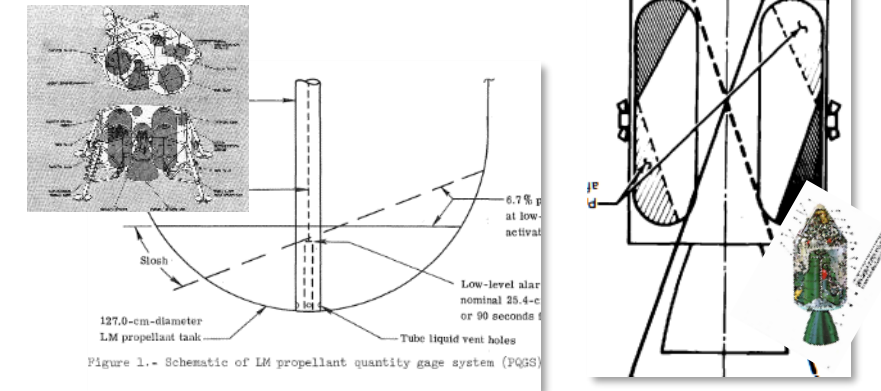

- 1) Apollo 11 SM retrograded towards CM after jettison due to slosh (ref 3.1.9-1)
- 2) Apollo 11 LEM slosh caused gage to be inaccurate while landing (ref 3.1.9-2)

# 3.1 Vehicle-to-Propulsion



[Boeing CST-100 Starliner Pad Abort Test | NASA Image and Video Library](#)

## 3.1.10 Propellant Draining and Center of Gravity Impacts

[PSR-23G] = Track shift in CG for series tanks and control differential draining

## 3.1.11 Load and Dynamics

[PSR-24S] = JSC 65829 in its entirety

[PSR-25G] = Thrust Overshoot Quantification

[PSR-26G] = Vehicle loads and deflection on propulsion system lines and supports

## 3.1.12 Unstable Dynamic Coupling of Engine/Thruster, Feed System, and Vehicle Structure (POGO)

[PSR-27S] = JSC-65829 LD93, 94

[PSR-28,29S] = SMC-S-025 6.4.4, 7.3.7, structure, engine compliance pump & pressure fed.

**Note High thrust liquid abort systems on spacecraft**

## 3.1.13 Thermal

[PSR-30G] = Thermal models to establish min/max temp limits not exceeded

[PSR-31S] = Thermal Model meet NASA-STD-7009 & validated with test data

[PSR-32S] = SMC-S-016 3.62 and 4.4.2 for thermal uncertainty margins

[PSR-33G] = Hardware and Fluids thermally controlled within ATP min max test

[PSR-34SC] = SMC-S-016 Qual and ATP Tables 6.3-1, 6.32, Section 6.3.8, 6.3.9, 7.3-1, 7.3

[PSR-35SC] = >3 C (5 F) Margin above freezing point of propellant in addition to the un

[PSR-36G] = >28 C (50 F) margin against auto decomposition temperatures in addition

[PSR-37G] = Thruster inlet propellant margin, relative to qualified operating box, minim

[PSR-38G] = Maintain gas pressurization systems 11 C above vapor condensation dew p

[PSR-39G] = Active and Passive thermal control shall be 1 FT against failure of the passi

[PSR-40G] = Test data for thermal parameters (e.g. emissivity, contact resistance)

[PSR-41SC] = Active cooling single string margin of 100% at initial design and 25% after



Apollo 15 CM RCS dump of raw fuel caused burning and damaged of riser

Ref 3.1.14-1



Figure 5: Apollo-Soyuz Test Project Crew

**Crew exposed to 750 ppm N2O4 due to entry sequence error firing thrusters with isolation valve closed during cabin repress. Pilot became unconscious.**

Ref 3.1.14-2

## 3.1.14 Vents

[PSR-42S] = JSC080802B F-1 with added provision vent flow restriction pressure in included in the cavity pressure (MDP)

[PSR-43G] = Venting shall be non-propulsive or net zero torque, unless intended (ie for settling propellant)

**[PSR-44G] = Propellant vents or leakage shall be evaluated for hazards such as compatibility with surrounding materials and ca**

**[PSR-45G] = shall be evaluated for freezing of the vented commodity that may block the vent or for other hazards.**

## 3.1.15 Anomaly, Issues, Problem Tracking and Resolution

[PSR-46SC] = JSC080802B G-15, Resolution of Flight Equipment Failures/Anomalies Prior to Launch augmented to include heritage

## 3.2 Propulsion System/Component Testing & SMC-S-016

### 3.2.1 General Test Requirements

[PSR-47S] = SMC-S-016 in its entirety with the following augmentation

[PSR-48G] = Perform Leaks tests before, during, and after vibration, shock, and thermal cycle, qualification and acceptance.

[PSR-49G] = Perform heritage qual gap assessment per Aerospace Report Number TOR-2013(3909)-1, Objective Reuse of Heritage Pro

[PSR-50G] = Trending of ATP data and out of family identification

[PSR-51G] = Planetary surface dust testing

### 3.2.2 System Level Qualification Tests

[PSR-52G] = **System Level Hotfire Qualification Test** with detailed requirements for high hardware fidelity and mission duty cycle profile

- a. Test scope in accordance with the requirements of section 8.0 in SMC-S-025
- b. Use of flight-representative fluid commodities.
- c. Use of flight-representative fluid components. (includes the flight instrumentation)
- d. Use of flight-representative fluid lines.
- e. Use of flight-representative engines/thrusters and pod/cluster configurations.
- f. Use of flight-representative thrust vector control (TVC) actuators and electronic controllers
- g. Use of flight-representative electrical power sources and valve driver avionics.
- h. **Use of equivalent passive and active thermal control elements for temperature conditioning of the engine/thruster hardware and propellants**
- i. Use of flight-representative servicing/deservicing and ground turnaround interfaces and procedures for the liquid and gaseous fluid commodities
- j. capability to fully saturate the liquid propellants with pressurant gas at all pressure/temperature conditions included in the test
- k. Perform hot fire sequences at vacuum (altitude) conditions and variable backpressure for entry vehicle applications
- l. **Mission profiles that encompass EPWs, DC%, and profile duration**
- m. content to demonstrate all nominal and contingency transient dynamic events in the pre-launch and in-flight concept of operation
- n. exposure of the hardware to all relevant external environments that could drive adverse interactions with the loaded propellants
- o. structural coupling and thrust dynamics evaluation to verify no unstable coupling of the mounting structure and liquid-propulsion system
- p. Includes content for engine/thruster chug and combustion stability evaluation per the requirements of JANNAF-GL-2022-0001 Combustion Stability Spec
- q. Utilizes a development instrumentation system needed to provide qualification data, as a supplement to the onboard flight instruments
- r. Utilizes a structured test readiness review (TRR) process to finalize all test plans and test procedures, document TLYF exceptions



**1998 Mars Polar Lander Failure, Post flight System Hot-fire Test Bed uncovered valve failure mechanism, Replicated only during system level hot-fire**

Ref 3.2.2-1

**System Level Hot-fire with Mission Duty Cycle Profile with Environments is a Critical Test**

## 3.2 Propulsion System/Component Testing & SMC-S-016

### 3.2.2 System Level Qualification Tests (cont.)

[PSR-53SC] = Complete propulsion system qualification prior to first uncrewed test flight

### 3.2.3 System level development tests

[PSR-54G] = Conduct engine and system level development tests to determine acceptability prior to CDR

### 3.2.4 Propulsion System and Component Acceptance, AI&T

[PSR-55SC] = Acceptance test at minimum and maximum predicted temperature extremes, ie use LH2 (SMC-S-016 only)

[PSR-56G] = Perform acceptance hot-fire test of engine assembly (SMC-S-016 does not require this explicitly)

[PSR-57SC] = Perform end-to-end gas flow test to check for blockages, JSC-08080 F20

[PSR-58S] = JSC 8080 2B G-3 Electrical and Fluid System Checkout

[PSR-59SC] = Perform Cryogenic propulsion system tanking tests and hot-fire acceptance testing

[PSR-60G] = Perform Hydrogen Peroxide propulsion system propellant loading and tanking down to thrusters for acceptance

### 3.2.5 Leakage Measurement

[PSR-61G] = Propulsion System Allowable leak rate determination

[PSR-62SC] = Use NASA-STD-7012 for leak measurement methods including supplementary provisions. Note: 7012 only says pick one.

[PSR-63G] = Specify that propulsion system shall be tested using 1) system level total decay, 2) local measurement, 3) spacecraft real-time leak check

[PSR-64G] = Specify that individual / local measurements shall use LTR 15 Method II accumulation (ie mass spec of joint wrapped in bag)

[PSR-65SC] = Special considerations for leak checking bellows and flexhoses using LTR 15

System Blockage Tests for Hypers, Green Run for Cryogenics,  
Global and Local Leak Tests



[SSC20210116 GR9312 | NASA Image and Video Library](#)

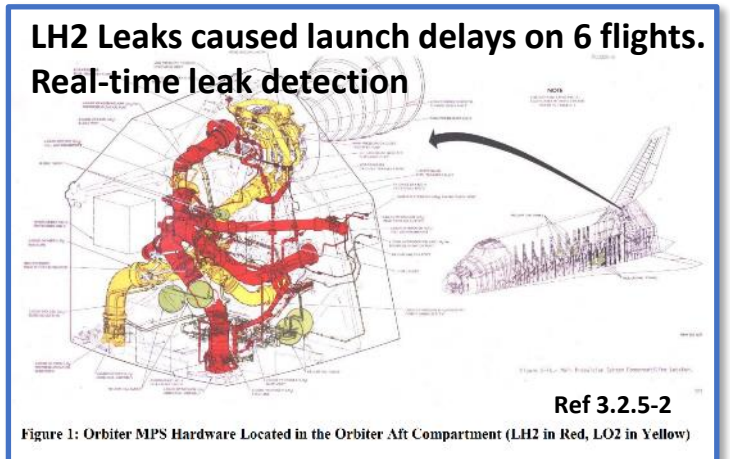

## 3.3 Propellant and Fluids Procurement and Usage, Hazards

### 3.3.1 General Fluid Procurement and Usage Requirements

[PSR-66G] = Procurement and usage spec of a propellant shall be utilized and controlled for the propulsion system; if none exists then one shall be created

[PSR-67G] = Manufacturing process change for propellants requires compliance verification and demonstration test with engine testing

[PSR-68G] = Propellant storage systems shall have specification for materials, soluble contamination, moisture, particulate, duration, pressure, temperature, saturation,

[PSR-69G] = Documentation of formal training for designers and operators in the use and hazards for all propellants and a formal process to identify hazards

### 3.3.2 General Fluid Interface, Sampling

[PSR-70G] = GSE filtered at the propulsion system interface to prevent particulate larger than the minimum size associated with the specified precision cleanliness level

[PSR-71S] = Sampling of Fluids per JSC 8080-2 F-27

[PSR-72G] = Sampling of ground storage vessel periodically prior to each spacecraft loading event and prior to refilling - concentration of other gases or contaminants (weathering)

[PSR-73G] = Sampling at the interface to the vehicle – check out GSE plumbing

### 3.3.3 Pressurants, Cold Gas

[PSR-74S] = Helium per MIL-PRF-27407 Type 1 Either grade A or B provide all qual tests and flight are done with the same fluid

[PSR-75S] = Nitrogen per MIL-PRF-27401 Grade B or C, (not A due to moisture and O2)

[PSR-76G] = inert gas hazards – asphyxiation , low temps, overpress of spacecraft compartments



Spacecraft fueling technicians from Kennedy Space Center take a sample of the monomethylhydrazine propellant

[KSC-2010-1055 | NASA Image and Video Library](#)



[Cryo Testing at ML, Pad 39B | NASA Image and Video Library](#)

## 3.3 Propellant and Fluids Procurement and Usage, Hazards

### 3.3.4 Monopropellants (including some that are used in bipropellant systems)

[PSR-77S] = Hydrazine per High Purity Hydrazine (HPH) per MIL-PRF-26536

[PSR-78S] = HPH assessed for contaminants not controlled in specification; [NESC Technical Bulletin 22-08](#),

[PSR-79S] = Hydrogen Peroxide per MIL-PRF-16005. NASA/TM-2005-213151

[PSR-80S] = Nitrous Oxide CGA G-8.2 QVL-A, Commodity Specification for Nitrous Oxide – Seventh Edition

### 3.3.5 Monopropellant Hazards

[PSR-81G] = Establish Component worst case temperature cause by environment and failures

[PSR-82G] = Maximum Allowable Hydrazine temperature of 160 deg F for valves and engine head end components (meeting NASA-STD-6016 and NASA-STD-6001)

[PSR-83G] = If engine valve and headend components wetted with hydrazine exceed 160 deg F, then additional testing is required

[PSR-84G] = Monopropellant shall be screened for variables that impact auto-decomposition temperatures (saturation, pressurization rates, heating rates, contaminations)

[PSR-85S] = JSC-8080-2F-6 Temperature and Pressure Monitoring Requirements for Potentially Hazardous Reactive Fluids

[PSR-86S] = AIAA SP-084-1999, Fire, Explosion, Compatibility, and Safety Hazards of Hypergols – Hydrazine

[PSR-87G] = Nitrous Oxide application shall be evaluated for hazards observed as reported in [Scaled Composites N2O Safety Guidelines 6.17.09.doc](#), AFRL-RZ-ED-TP-2008-184

[PSR-88S] = Hydrogen Peroxide systems shall be evaluated for hazards per NASA HYDROGEN PEROXIDE PROPELLANT

[PSR-89G] = Hydrogen peroxide systems shall follow documented and proven/verified contamination control and

[PSR-90G] = The occurrence of cavitation shall be evaluated and avoided in hydrogen peroxide systems. Reference

[PSR-91G] = Evaluation of the increased catalytic effect of materials of construction on decomposition of hydrazine

[PSR-92G] = Evaluate adiabatic / rapid compression detonation of monopropellants with presence of decomposition

[PSR-93G] = Throat plugs for engines/thrusters using monopropellant hydrazine shall have a flow through purge to

[KSC-2014-4771 | NASA Image and Video Library](#)

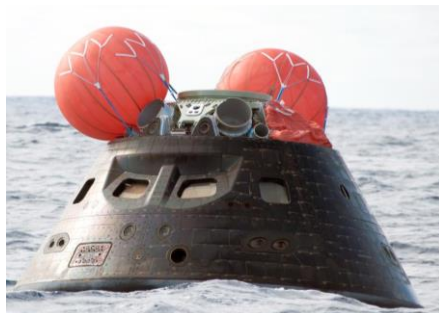

[KSC-MA9-174 | NASA Image and Video Library](#)



### Nitrous Oxide Explosive Hazards

Eindhoven, Netherlands N<sub>2</sub>O explosion – Semitrailer exploded down stream of centrifugal pump but N<sub>2</sub>O storage tank survived intact. <sup>[7]</sup>  
- Hot pump unlikely cause for explosion since incident did not occur until five minutes after pumping started.

No flashback to storage tank indicates large N<sub>2</sub>O systems could be safe.

[6] "Nitrous Oxide Trailer Rupture". July 2, 2001, The Netherlands, Eindhoven.pdf file; Report at CGA Seminar, "Safety and Reliability of Industrial Gases, Equipment and facilities", Konrad Munke, St. Louis, Missouri, October 15-17, 2001.

Ref 3.3.5-2

Human Spacecraft are being developed with many different propellants or new usage, Need to Understand Hazards

## 3.3 Propellant and Fluids Procurement and Usage Specification

### 3.3.5 Bipropellants

[PSR-94S] = MIL-PRF-25508, Performance Specification, Propellant, Oxygen

[PSR-95S] = MIL-PRF-27201, Performance Specification, Propellant, Hydrogen

[PSR-96SC] = MIL-PRF-26539, Performance Specification Propellants, Dinitrogen Tetroxide, Clarify water content below 0.05% and iron content below 0.1 ppmw

[PSR-97G] = Nitric Oxide (NO) content greater than 1% must be maintained during all operations of the propulsion system (NO will vaporize off )

[PSR-98S] = MIL-PRF-27404, Performance Specification Propellant, Monomethylhydrazine

[PSR-99S] = MIL-PRF-32207, Performance Specification, Propellant, Methane. (includes procurement as LNG)

[PSR-100S] = MIL-DTL-25576, Detail Specification Propellant, Rocket Grade Kerosene

### 3.3.6 Bipropellant Hypergolic MMH/NTO hazards

[PSR-101S] = AIAA SP-086-2001 (NTO), "Fire, Explosion, Compatibility, and Safety Hazards of Nitrogen Tetroxide." and AIAA SP-085-1999 "...Hazards of Hypergols MMH"

[PSR-102G] = shall implement and maintain at all time a dry low dewpoint verified purge at all dynamic and environmental seals and openings

[PSR-103G] = Throat plugs shall have a flow through purge to prevent NTO/MON3 propellants from reacting at wetted fuel seat and to reduce moisture exposure at oxidizer seat

[PSR-104G] = Teflon flexhoses are not allowed in spacecraft system due to permeation of propellants

### 3.3.7 Cryogenic hazards

[PSR-105S] = Oxygen Safety Standards ASTM G88-21 is called out by NASA-STD-6016 for material flammability. JSC has a cryo safety manual, as well as other centers. [JPR 1700.1M-Chpt 6.4](#)

[PSR-106S] = ANSI/AIAA G-095A-2017, Guide to Safety of Hydrogen and Hydrogen Systems [also called out in JPR 1700.1M-Chpt 6.4]

[PSR-107G] = Evaluate hazards due to boil-off that will increase concentration of other hydrocarbons and oxygen

[PSR-108G] = Evaluate hazards due to any sub-cooling below normal point of the cryogenics (air liquefaction)

[PSR-109G] = Evaluate boiling liquid evaporative explosion (BLEVE)

[PSR-110G] = Low dewpoint purge and monitor dewpoint to prevent ice formation and plugging

### 3.3.8 Propellant Properties

[PSR-111G] = Use propellant properties traceable to NIST

[PSR-112G] = If properties do not exist, use NIST methodology and/or processes to obtain or estimate

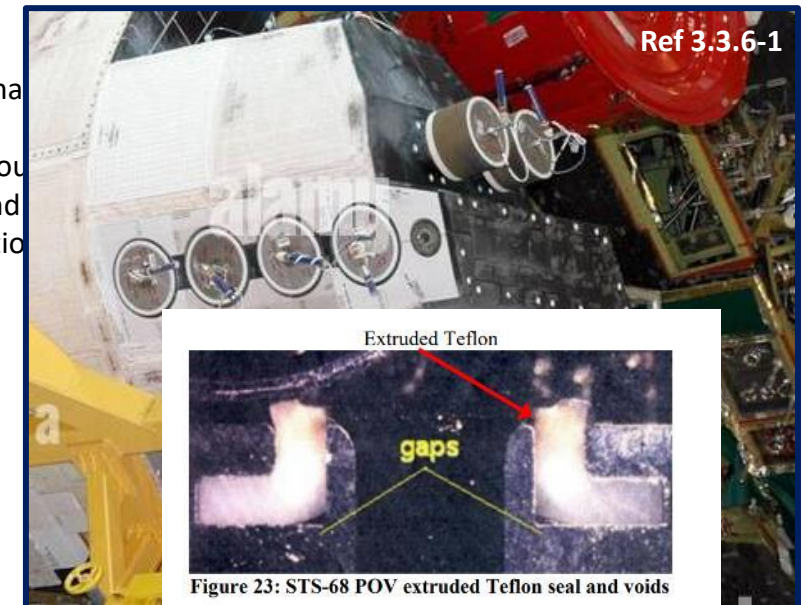

There are some unique hazards with each propellant

## 3.4 Materials and Processes (M&P) and Fluid Compatibility

### Common-cause failures of multiple thrusters in flight

- Corrosion due NTO + DI Water w/Chlorides,
- Soft good swell

#### 3.4.1 M&P NASA-STD-6016

[PSR-113S] = NASA-STD-6016 STANDARD MATERIALS AND PROCESSES REQUIREMENTS FOR SPACECRAFT

[PSR-114G] = GSE must also meet NASA-STD-6016

#### 3.4.2 Test and Assembly Fluids; Cleaning, Flushing, and Drying

[PSR-115SC] = DI Water shall meet the requirements of ASTM D1193, Type I (any grade) or Type II (any grade), shall include 'monitoring' content of Appendix X1.3

[PSR-116S] = IPA per TT-I-735 Grade A, with the final rinse and sampling using reagent grade or better.

[PSR-117S] = CGA G-11.1, Commodity Specification for Argon, Quality Verification Level (QVL) C, D, E, or F, or MIL-PRF-27415,, Argon, Grade A or B

[PSR-118S] = HFE per A-A-59150 [Work is occurring to find a substitute]

[PSR-119S] = Leak Detection Fluid per MIL-PRF-25567

[PSR-120G] = Assess compatibility of cleaning fluids with propulsion system materials and fluids

[PSR-121G] = shall perform verification of dryness at component level during acceptance testing and at integrated propulsion system level after cleaning/flushing

#### 3.4.3 Material Compatibility and Tests

[PSR-122G] = Qualification of systems and components shall include full duration exposure tests to propellants, environment, and other relevant fluids (not just coupon tests)

[PSR-123G] = Fluid and manufacturing tooling material compatibility (ie, internal tube bending tooling, etc)

[PSR-124G] = NTO applications should limit the use of CRES

[PSR-125G] = Failure of sensor diaphragm and Material compatibility

#### 3.4.4 Propellant Oxidizer and Material Ignition and Combustion

[PSR-126SC] = NASA-STD-6016C 4.2.1.4 (Oxygen Compatibility) or 4.2.1.3 (Fluid Compatibility, Fluids Other Than Oxygen) with

#### 3.4.5 Softgoods

[PSR-127S] = Shall assess soft good properties change with propellant and cleaning fluid exposure at temp, and pressure (sw

[PSR-128G] = Cleaning fluids must be specific to propellant intended under use

[PSR-129G] = Swapping ox and fuel components after cleaning or exposure to propellants is not allowed. Require full disasse

### Shuttle STS-9 APU 1 Explosion

*The APU failures most probably resulted from a crack in the injector stem caused by corrosion of the sensitized inside diameter surface. The corrodant is probably carbazic acid or some similar substance which can be derived from air, moisture, CO<sub>2</sub>, hydrazine and/or ammonia. The corrosion is time dependent and the crack progressed under sustained stress levels from the inner diameter surface toward the outer diameter surface until mechanical or thermal fatigue conditions could [complete] the crack rupture."*

KSC-2010-045R, Hypergolic Propellants: The Handling Hazards and Lessons Learned from Use (<https://ntrs.nasa.gov/citations/20100042352>)

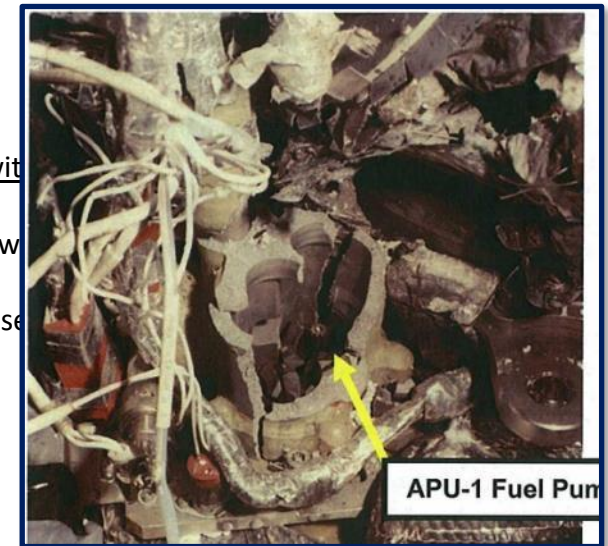

Ref 3.4.3-1

## 3.4 Materials and Processes (M&P) and Fluid Compatibility

### 3.4.6 Propulsion System Cleaning

[PSR-130S] = NASA STD-6016 Sections 4.2.6.7 and 4.2.6.8 (also Meets JSC 8080 F-17 and F-19)

[PSR-131SC] = IEST-STD-CC1246 with added provision that no particles larger than maximum

[PSR-132G] = Final Cleanliness Verification of components with liquid (e.g. HFE, IPA) and component vacuum dried

[PSR-133SC] = Spacecraft assembly at Class 8 per ISO 14644-1 (note equiv. to Class 100,000 per FED-STD-209E)

[PSR-134G] = lines designed to be capable of final verification of cleanliness and after R&R (flush, borescope, xray)

[PSR-135G] = Feedline capable of being removed for cleaning after any trim to fit prior to welding

[PSR-136G] = Surveillance on Tube segments and welded assemblies with borescope inspection and sampling

[PSR-137G] = For tubing where borescope inspection is not possible, then process demonstration can use next size up

[PSR-138G] = Precision cleaning of the borescope used for internal inspections

[PSR-139G] = Verified tube cutting process and tool maintenance

[PSR-140G] = Protecting against system contamination during tube preparation

[PSR-141G] = verification by 1) inert gas flow process demonstrated to move particles, 2) internal borescope, 3) x-ray

[PSR-142G] = TWFPB need a specific process developed and verified.

[PSR-143G] = Flexhose Cleaning

### 3.4.7 External FOD Control

[PSR-144S] = JSC 8080-2b and NAS412 FOD prevention

[PSR-145S] = JSC 8080-2B G4 FOD protection

[PSR-146G] = Features to prevent 1) leaving it in-place inadvertently, 2) dropping into the plumbing, or 3) shedding pieces

[PSR-147G] = Locking feature on GSE threaded fasteners interfacing with flight hardware openings

[PSR-148G] = Periodic inspections and closeout photos to insure no loose parts or FOD

[PSR-149G] = Dry purge or Seal against moisture-laden air intrusion

[PSR-150G] = Ingestion of water into the propulsion system and engine chambers

### 3.4.8 Welding and Bimetallic Joints

[PSR-151S] = Welds per NASA STD 6016 Class A

[PSR-152G] = Clarify MIL-STD1252, Bimetallic Inertial Welds or transition joints shall have lot testing and acceptance using first and last SEM examined for brittle intermetallic

Metal  
Particles  
seen in X-  
ray



Contamination  
found by  
Borescope  
after tubing  
Verified Clean



### MSL Descent Stage Ref 3.4.8-1

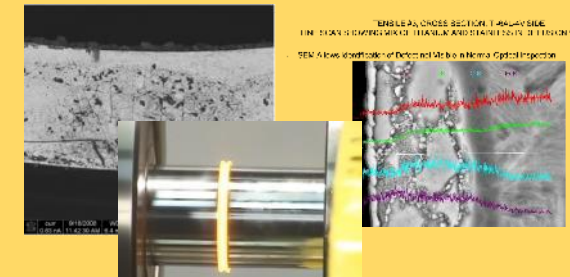

### Brittle Bi-metallic Joints

Hydrazine  
Thruster Valve  
Leak

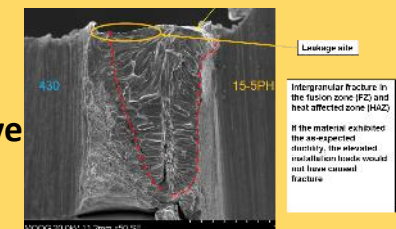

## 3.5 Propulsion System Pressurized Hardware

### 3.5.1 MDP

[PSR-153S] = JSC 65828 STR0022 Pressure regulators, relief devices and thermal control systems (e.g.heaters) shall collectively be two-fault tolerant to exceeding MDP

[PSR-154SC] = MDP shall include relief system setpoint. Exception to JSC-65828 3.2.8.3 STR0021 which allows MDP exceedance by 10% during relief of pressure

[PSR-155G] = NASA/TM-20210022275, Treatment of Transient Pressure Events in Space Flight Pressurized Systems

### 3.5.2 Fracture

[PSR-156S] = NASA-STD-5019 Rev A w/ Change 2, Fracture Control Requirements for Spaceflight Hardware

### 3.5.3 NDE

[PSR-157S] = NASA-STD-5009 Rev A, Nondestructive Evaluation Requirements for Fracture-Critical Metallic Components

### 3.5.4 Threaded Fasteners

[PSR-158S] = NASA-STD-5020 Rev A, Requirements for Threaded Fastening Systems in Spaceflight Hardware

### Maximum Design Pressure (MDP):

- The Maximum Design Pressure (MDP) for a pressurized system is the highest pressure defined by the maximum relief pressure, maximum regulator pressure, maximum temperature and transient pressure excursions based on two credible system failures.

National Aeronautics and Space Administration  
NASA Engineering and Safety Center Technical Bulletin No. 22-03 Ref 3.5.1-1

### Treatment of Transient Pressure Events in Space Flight Pressurized Systems

Analytical and experimental evidence shows that fast-moving dynamic pressure fluctuations caused by valve actuation, fluid-system priming, fluid discharge, vibration, and flow disturbances can elicit adverse structural response and must be considered in the space flight pressure system design and verification process.

#### Background

Transient pressure events are fast-moving dynamic fluctuations due to disruptions within the pressurized systems, Figure 1. Since numerous factors influence pressure transients, a comprehensive approach to treating these is absent. Vague or contradictory requirements have led hardware developers to bypass this assessment. Structural failures have occurred in aerospace applications from overloads or fatigue from transients.

subjected to a half-sine traveling pressure wave showed that the ratio ( $\omega^*$ ) of pressure wave frequency ( $\omega$ ) to the ring natural frequency ( $\omega_n$ ) of the pipe was a key parameter in DAF calculations.

$$\omega^* = \omega / \omega_n = r \omega \sqrt{E / \rho} \quad (\text{rad/s})$$

Three outcomes are possible:

- $\omega^* \ll 1 \rightarrow$  similar to static pressure load, DAF = 1
- $\omega^* = 1 \rightarrow$  resonance, response is amplified, DAF = 3
- $\omega^* \gg 1 \rightarrow$  structure responds slower than the load, DAF = 0

#### Pressure Vessels vs. Pressure System Components

The transient pressure wave entering fluid storage vessels, such as tanks and pressurized structures, dissipates due to relatively large volume compared to that of the connecting pipe. In these cases, DAF is zero and the magnitude of the pressure transient is added to the steady state pressure to define MEOP. Pressurized components, such as pipes and valves, may show a minimal dynamic response (DAF=0.0), a quasi-static response ( $0.0 < \text{DAF} < 1.0$ ), or an amplified response ( $\text{DAF} \geq 1.0$ ).

#### Verification Process

Establish a MEOP that mimics a localized maximum stress at the critical location, which is equivalent to that of steady state pressure

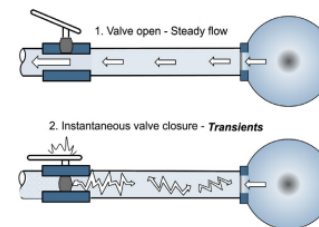

Figure 1: Illustrations of Pressure Transients

Treatment of Transient Pressure Events (Pressure Spikes) Needs Clarification

## 3.6 Pressure Vessels and Propellant Tanks

### 3.6.1 Integrated Propellant Tanks

[PSR-159G] = full tank assembly level (Pressure Vessel + PMD + Lines + Supports) analysis and test requirements for structural integrity and material compatibility

### 3.6.2 Type I Metallic Pressure Vessels

[PSR-160S] = JSC 65828, including paragraph 3.2.8.4 [STR0022] governing Metallic Pressurized Hardware

[PSR-161SC] = Clarify 1.25 proof/1.5 Burst tank can meet JSC-65828, with NDE, and disallow proof pressure as sole means of flaw screening.

[PSR-162S] = NASA-STD-5009 NDE

[PSR-163G] = **POD of 90/95 that accounts for double-wall radiography of metallic pressure vessels. NESC Technical Bulletin 19-02**

[PSR-164G] = Aspect ratios at A/C=1.0 and A/C=0.2 shall each be evaluated.

### 3.6.3 Type II and III COPV

[PSR-165S] = JSC 65828, including paragraph 3.2.8.5 [STR0023] governing Composite Overwrapped Pressure Vessels (COPVs).

[PSR-166SC] = Models shall be correlated to the qualification tank per JSC-65828 STR066, STR0067, STR0068, STR0070.

[PSR-167G] = **Bond line sensitivity studies shall be performed for tanks. NASA NESC Technical Bulletin No.20-07**

[PSR-168G] = POD of 90/95 that accounts for double-wall radiography of metallic liners tank welds.

[PSR-169S] = NDE methods in NASA-STD-5009 shall be followed

[PSR-170G] = Aspect ratios at A/C=1.0 and A/C=0.2 shall each be evaluated

Ref 3.6.3

National Aeronautics and Space Administration

**NASA Engineering and Safety Center Technical Bulletin No. 20-07**

### Evaluating and Mitigating Liner Strain Spikes in COPVs

Unexpected cracking and leaking in bonded composite overwrapped pressure vessel (COPV) liners occurring in recent test programs have been attributed to liner strain spikes observed through measurement and predicted by analysis. Diminished load transfer between the liner and composite overwrap can lead to localized excessive liner yielding in the dome section. This diminished constraint can occur due to yielding of the adhesive or a manufacturing unbond defect. COPVs should be assessed for susceptibility to this new failure mode.

**Background**

3. Add a clipboard icon at the location where the adhesive is



Additional pressure vessel NDE requirements and integrated tank are required

## 3.6 Pressure Vessels and Propellant Tanks

### 3.6.4 Type IV Composite with plastic liner

[PSR-171G] = JSC ES 151001-1 "Use of ASME Code or CFR 49 (DOT) Pressure Vessels

[PSR-172SC] = AIAA-G-082: 2022 - Guide: Space Systems - Composite Overwrapped Pressure Vessels With A Plastic Liner. Not Sufficient by itself for human spaceflight

[PSR-172aG] = Tank design and qualification standards shall be reviewed by NASA appointed SME.

[PSR-172bG] = Tests of mission representative duration if reactive media can penetrate the overwrap either by permeation or submersion

[PSR-172cG] = Composite compatible with all fluids contacting it thru permeation, without detrimental deformation, leakage, or rupture

[PSR-172dG] = Controls shall be listed for the raw materials used to make the liner

[PSR-172eG] = Assessment for damage tolerance

[PSR-172fG] = Statistical basis for material properties is required for all materials including the liner material

[PSR-172gG] = External pressure conditions need to be examined for conditions of vacuum filling, purge, applied external pressure and buckling

[PSR-172hG] = determine credible sources of mechanical damage to the COPV. These credible sources will be provided in the Damage Control Plan(DCP)

[PSR-172iG] = Unique ascent and space operating environments shall be examined more closely for Type IV CPV with plastic liner.

[PSR-172jG] = designed to sustain the negative pressure differential without detrimental deformation, detrimental leakage, or rupture

[PSR-172kG] = Examination of full saturation when assessing for permeation shall be performed.

[PSR-172lG] = credible flaws/indications are identified through an assessment the credible range of sizes/shapes/depths and shall direct the NDT capabilities

### 3.6.5 Type V all composite

[PSR-173G] = No standard exists for Type V. Need to develop one.

## 3.6 Pressure Vessels and Propellant Tanks

### 3.6.6 Liquid PMD

[PSR-174G] = PMD in a liquid propellant tank shall provide gas-free liquid to the propellant feed lines during engine/thruster operation under

[PSR-175G] = surface tension screen galleries in a liquid propellant tank, a minimum safety factor of 2.0 for bubble point

[PSR-176G] = surface tension vanes in a liquid propellant tank, minimum safety factors of 3.0 on friction/flow losses and 2.0 on surface tension

[PSR-177G] = sponges in a liquid propellant tank, a minimum safety factor of 2.0 for the deliverable volume vs. the demand volume shall be

[PSR-178SC] = Positive expulsion thin wall flexible metallic bellows or diaphragms shall meet the fracture control requirements or TWFPB JSO

[PSR-179G] = Positive expulsion elastomeric and metallic design shall include assessment of the material compatibility and permeation of propellant

[PSR-180G] = Diaphragm delta pressure limits

[PSR-181G] = PMD, attached to the pressure vessel wall as part of the propellant tank assembly, shall be qualification tested...

[PSR-182G] = Performance testing of the integrated propellant tank assembly as part of unit qualification and acceptance per SMC-S-016

### 3.6.7 Slosh Damping Device

[PSR-183G] = slosh damping devices within a propellant tank shall be designed to mitigate swirl motion (single and multi-tank), vortex, and lateral

[PSR-184G] = Performance of the slosh damping devices within a propellant tank shall be demonstrated through a combination of analysis and test

[PSR-185G] = Slosh features shall meet structural margins and test requirements

### 3.6.9 Gauging and Un-usables

[PSR-186G] = design of a spacecraft propulsion system shall incorporate a method of propellant quantity gauging to address the inadvertent depletion

[PSR-187G] = if burn time integration is only gauging method, a separate means of detecting external/overboard propellant leakage and off-nominal

[PSR-188G] = Any uncertainty or error associated with the propellant gauging method shall be considered as unusable commodity

[PSR-189G] = Performance verification of the propellant quantity gauging method shall be accomplished via testing, a 3-sigma Monte Carlo analysis

[PSR-190G] = Any uncertainty associated with the propellant loaded into the propulsion system during pre-launch ground operations shall be controlled

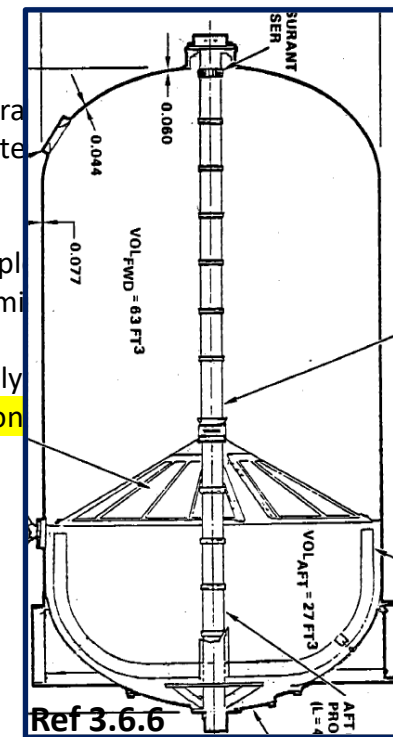
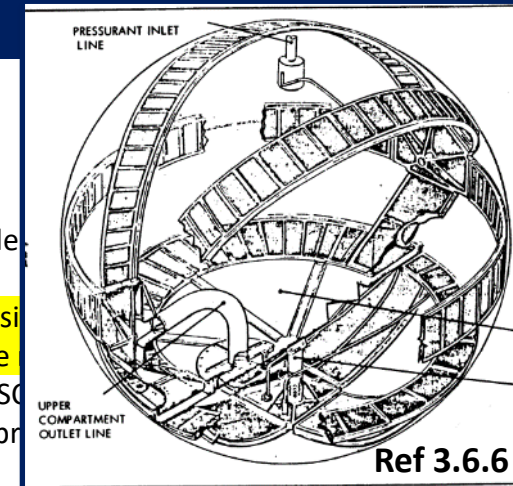

# 3.7 Pressurization Subsystem

## 3.7.1 Pressure Reg System (Series and Parallel configuration of iso valves, regulator/valve, filter, check valves)

- [PSR-191G] = shall specify outlet pressure range as a function of flowrate and inlet pressure in the system
- [PSR-192G] = shall be dynamically stable with a return to stable operation, no sustained organized oscillation
- [PSR-193G] = shall be tested for slam start transients to measure overshoot when the system is activated
- [PSR-194G] = overshoot pressure upon termination of flow shall remain below the hardware MDP and RV setpoint
- [PSR-195G] = overshoot pressure shall account for liquid that may in zero-g be located in the pressurization system
- [PSR-196G] = fault tolerance shall include failures in the element
- [PSR-197G] = each serial or parallel stage in a redundant configuration
- [PSR-198G] = each serial or parallel stage in a redundant configuration

## 3.7.2 Overpressure Protection

- [PSR-199G] = shall Provide full flow relief at 100% of the system pressure
- [PSR-200G] = shall perform Pressure relief device performance
- [PSR-201G] = relief device, vent line location, and vent line size
- [PSR-202G] = a positive (i.e. non-permeable) vapor barrier

## 3.7.3 Reactive Vapors

- [PSR-203S] = 'separation of hypergolic reactants' requirement
- [PSR-204SC] = Check valves, valves, elastomers, and tank
- [PSR-205G] = shall control of condensation of propellant vapor
- [PSR-206G] = Use of common pressurization restricted to short duration
- [PSR-207G] = Propellant tank pressurization port liquid return

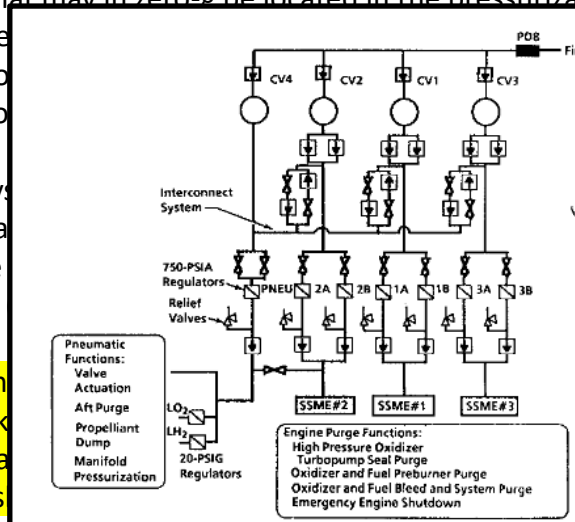

Fig. 2 MPS helium system.

Shuttle MPS Helium Pressurization Panel experienced regulator instability causing fail open, RV popping open during activation, check valve chatter, isolation valve bellows failure, etc

Ref 3.7.1-1

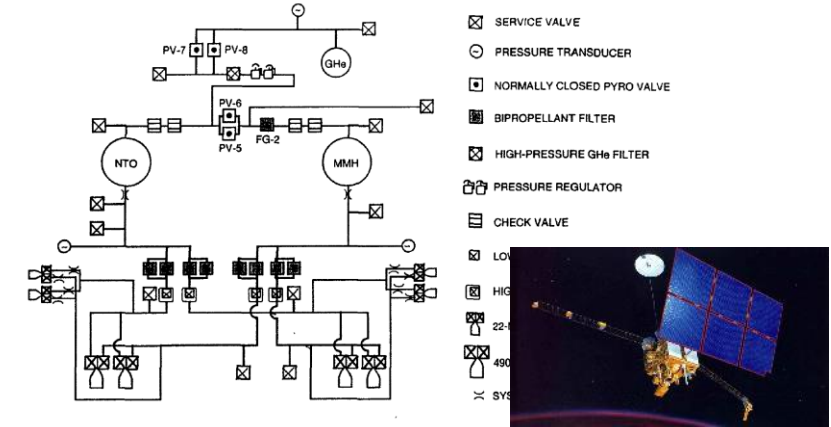

Figure 2 - Mars Observer Bipropellant Propulsion System Schematic

## Loss of Mars Observer occurred upon system pressurization for Mars Orbit insertion burn

- Mars Observer (MO) was a satellite propulsion system designed for an early mission apogee burn, but was repurposed for planetary missions
- MO Loss was due to either Regulator Fail Open- NTO Corrosion\*, Regulator leakage due to Contamination, Reaction of Ox and Fuel, Pyro valve failure (expulsion of NSI)
- \*Regulator Fail Open NTO Corrosion is most likely: Filter/screen used AMS 4774 Braze material that was not compatible with NTO and was not called out on drawings for review. Corrosion was dislodged during pyro firing and plugged regulator sense orifice.

Ref 3.7.3 Guernsey, C. S., 2001, "Propulsion lessons learned from the loss of Mars Observer", <https://hdl.handle.net/2014/36825>, ['37th AIAA/ASME/SAE/ASEE Joint Propulsion Conference', 'Salt Lake City, UT, USA'], JPL Open Repository; 01-1441.pdf

Catastrophic Hazards Include Loss of Helium (Prop Function), Rupture due to Mixing of Ox and fuel

## 3.8 Propulsion System Valves

### 3.8.1 General Requirements for Valves

[PSR-208S] Valves shall meet all requirements in NASA-STD-5017

[PSR-209G] Reserved for future NASA standard on valves

### 3.8.2 Dimensional Analysis and Clearances

[PSR-210G] Include effects of propellant exposure in NASA-STD 5017 4.1.2

### 3.8.3 Torque/Force Margin Analysis

[PSR-211SC] Valve torque and force margin analysis account for pressure transients, avionics/wiring, in NASA STD-5017 4.3.3.1 DDMR9 (missing)

[PSR-212SC] Include effects of propellant exposure and soft good swell/permeation in NASA STD-5017 4.3.3.1 DDMR9 (missing)

### 3.8.4 Cycle Life

[PSR-213SC] Include wet and dry ground cycles in cycle life – clarify 4.19.3.2 DDMR75 NASA-STD-5017

[PSR-214SC] Cycle life shall be based on fault cases and 3 sigma GNC Monte Carlo simulations – augment 4.19.3.2 [DDMR75] of NASA-STD-5017

[PSR-215G] factor of 4x on the specified cycle-life of the unit, spread across the full range of applicable operating conditions for the hardware

### 3.8.5 Valve Electrical

[PSR-216S] shall comply with the requirements of NASA-STD-8739.10, Electrical, Electronic, And Electromechanical (EEE) Parts Assurance Standard

[PSR-217S] shall comply with the requirements of EMI/EMC for space systems per MIL-STD-461G

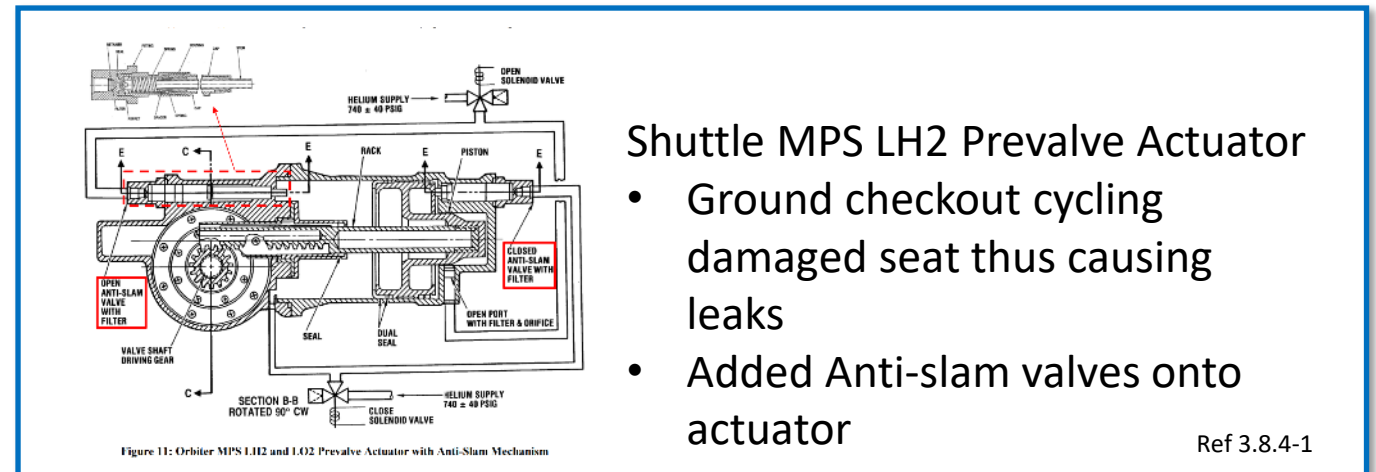
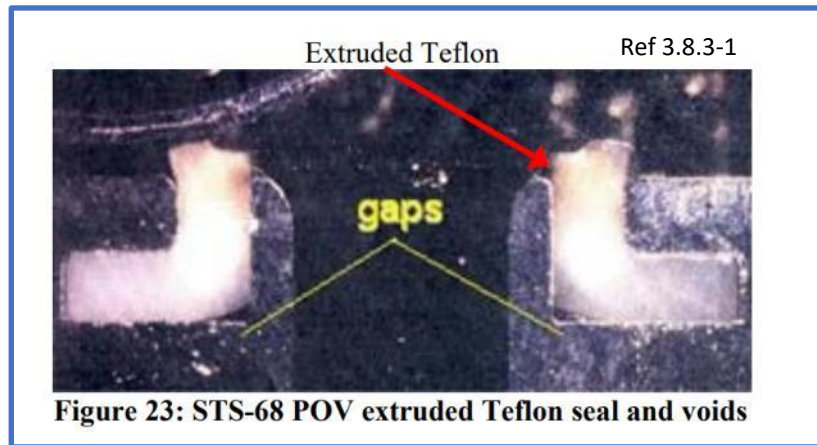

Contamination, Incorrect Materials for Propellant Exposure & Environment, Not Accounting for how Operated, Insufficient Qualification, Acceptance Testing, Quality Control, etc

## 3.9 Propellant Feed System

### 3.9.1 Propellant Feed System and Engine Interface Conditions

- [PSR-218G] Propellant Feed system designed to meet engine interface limits for pressure, temperature, gas bubbles, over mi
- [PSR-219G] Integrated dynamic analysis of system and engine chamber pressures (water hammer, slumps, overpressures) ov
- [PSR-220G] Pressure slump in feed system shall maintain 1.25 margin over propellant vapor pressure to avoid bubble collaps
- [PSR-221G] Assume all dissolved gases come out of solution thru pressure drops (NESC Tech Bulletin 22-07)

### 3.9.2 Propellant Feed System Activation; Priming and Repriming

- [PSR-222G] concept of operations for the propellant feed system activation shall be determined at SDR
- [PSR-223G] redundant instrumentation to monitor pressure shall be provided in each isolated manifold to ensure non-hazar
- [PSR-224G] priming/repriming analysis shall encompass the worst-case pressure, propellant quality, propellant vapor and no

### 3.9.3 Propellant Feed System Maximum Design Pressure Transients

- [PSR-225G] determination of MDP values for the hardware shall include all water-hammer or surge transient conditions and
- [PSR-226G] dynamic amplification factor shall follow NASA/TM-20210022275, Treatment of Transient Pressure Events in Spa

### 3.9.4 Feed System Model Verification and Validation

- [PSR-227G] breadboard/prototype system level test, including wetted propellant lines, shall be conducted by PDR
- [PSR-228G] feed system analysis, that is anchored to test data using referee fluids and/or actual propellants, shall be conduc
- [PSR-229G] feed system model per NASA-STD-7009, Standard for Models and Simulations, and be maintained/updated in th

### 3.9.5 Propellant Isolation – Inhibits to Bulk Propellant Loss

- [PSR-230G] shall provide a minimum of three (3) independently verifiable mechanical inhibits to the leakage/release of bulk
- [PSR-231G] shall provide a minimum of two (2) inhibits to the leakage/release of bulk propellant through the intended prope
- [PSR-232G] Mechanical joints shall provide a minimum of two (2) independently verifiable mechanical inhibits to the leakage
- [PSR-233G] Propellant service valves shall provide three (3) mechanical inhibits to the release of bulk propellant, minimum o

### 3.9.6 Feed system back pressure relief

- [PSR-234G] Sections of tubing where propellants may be trapped (e.g. hydraulically locked) shall include redundant pressure

### 3.9.7 Fluid Line Design, Routing and Installation

- [PSR-235G] Detailed drawings and CAD shall be provided for design routing and installation procedures of all fluid lines in the
- [PSR-236 G] fluid line design and analysis shall consider vacuum and gravitational effects, ranging from 1-g to zero-g,

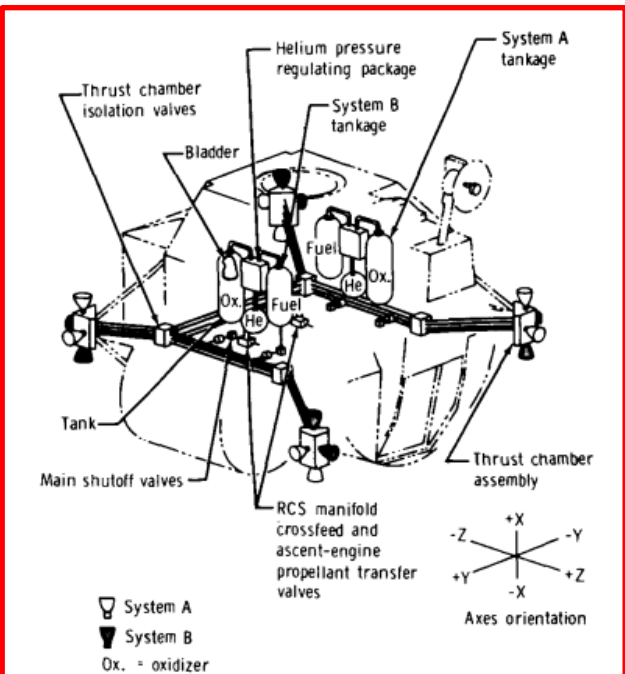

Figure 2. - Reaction control system installation.

Apollo LM Breadboard/Prototype system uncovered issues with thruster inlet dropping to vapor pressure resulting in zero thrust, transient pressure exceeding proof pressure

Ref 3.9-1

Feed system water-hammer and surge pressure are major source of failures and hazard such as ACD

## 3.10 General Requirements for Mechanical Fittings, Joints and Flanges

### 3.10.1 Use of Mechanical Fittings/Joints vs. Brazing or Welding

[PSR-237G] use of separable mechanical fluid fittings/joints shall be limited to the situations outlined in paragraph MS-15 of

### 3.10.2 Mechanical Fitting, Joint, and Flange Design, Qualification, & Acceptance

[PSR-238G] Mechanical fittings, such as K-seals and Dynatubes, joints, and flanges shall meet following design, qualification

[PSR-238a] = D: shall contain at least two seals or sealing surfaces in the design

[PSR-238b] = D: shall be verified capable of independently performing the intended sealing function

[PSR-238c] = D: shall have a verifiable positive restraint to preclude loss of seal load

[PSR-238d] = Q: Certification data, when required, shall be summarized by the provider

[PSR-238e] = Q: Test data showing that each individual seal is capable of independently performing the intended

[PSR-238f] = Q: Vibration qualification test data, subsequent leak tests, to qualify the fitting/joint design for the

[PSR-238g] = Q: Thermal cycle qualification test data, subsequent leak tests, and supporting analysis shall be

[PSR-238h] = Q: Pressure cycle qualification test data, subsequent leak tests, and supporting analysis shall be

[PSR-238i] = Q: Test showing proof, burst, yield and ultimate combined load safety factors of the fittings/joints shall meet

[PSR-238j] = Q: Analysis, procedures, and test data qualifying the leak rate of the fluid fittings/joints up to MDP

[PSR-238k] = Q: Engagement/disengagement cycle test data to qualify the fitting for the predicted processing cycle life

[PSR-238l] = Q: Compatibility data for fitting/joint materials for the fluid and environmental exposure conditions and

[PSR-238m] = Q: Test data shall show the ability of the fitting/joint design to meet leakage requirements given dispersion

[PSR-238n] = Q: include assembly procedures, manufacturing, mis-alignment, under and over-torque, thread relaxation

[PSR-238o] = Q: Seal savers, if used to repair a leaking joint, shall be qualified and accepted with the same requirements

[PSR-238p] = A: parts shall be of design materials

[PSR-238q] = A: parts meet drawing requirements for surface finish, flatness, tolerances, mechanical features

[PSR-238r] = A: parts shall be proof tested at 1.5MDP, inclusive of each independent seal in flanged joint.

[PSR-238s] = A: Parts shall be cleaned and verified per the drawing or system requirements

[PSR-238t] = A: parts shall be assembled with designated observer (MIP) to verify workmanship, photograph, no FOI

[PSR-238u] = A: torque check operation shall have 24 hours between first torque and final torque check

[PSR-238v] = A: Parts shall be leak tested at 1.0xMDP after final mating, inclusive of each independent seal in a flanged

Ref 3.10.2-1

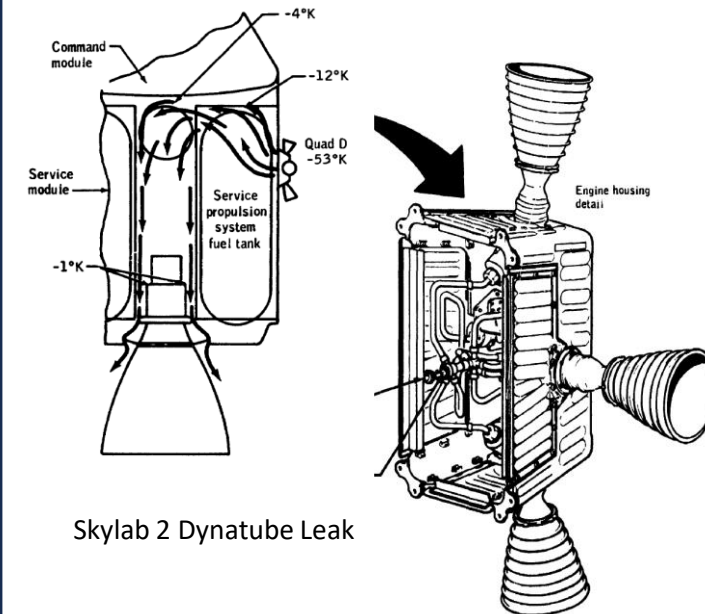

Skylab 2 Dynatube Leak

Ref 3.10.2-2

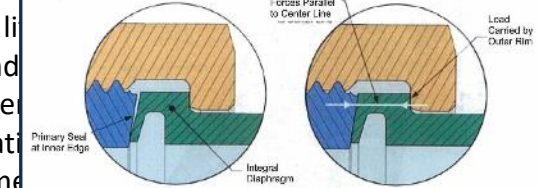

Figure 28: Cross-Section of Dynatube Sealing Surface

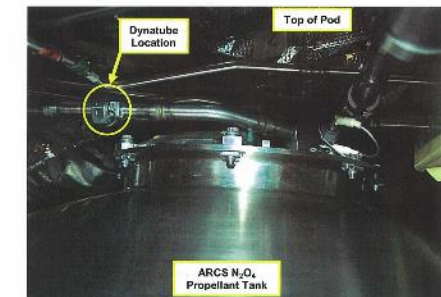

Figure 27: Dynatube Location on ARCS N<sub>2</sub>O<sub>4</sub> Tank

Requirements for Mechanical Fittings and Joints was only in program documentation (ie CCP)

## 3.11 Fluid Transfer Couplings (FTC) and Fluid Transfer Systems (FTS)

### 3.11.1 In-Flight Refueling Couplings

[PSR-239S] AIAA-S-157 “In Space Storable Fluid Transfer for Prepared Spacecraft” shall be used for requirements that control catastrophic hazards

[PSR-240SC] FTS shall incorporate 3 barriers against external leakage with the fluid coupling demated or mated and with isolation valves as a barrier

[PSR-241SC] FTC shall include 1 FT sealing features that are in place prior to or during the engagement or disengagement of poppets

[PSR-242G] FTC shall incorporate filter elements installed immediately upstream and then at some point downstream

[PSR-243G] FTC shall have caps or covers that can remain installed on the flight and ground halves individually when not mated,

[PSR-244G] FTC shall undergo leak checks of the coupling unmated or mated, prior to and during in-flight fluid transfer operations

[PSR-245G] FTS shall have isolation valves upstream and downstream of the FTC that are used for starting/stopping fluid flow (do not use coupling mate/demate)

### 3.11.2 Separation of Spacecraft Modules

[PSR-246S] shall follow ‘fluid lines separation’ requirements of paragraph F-5 in JSC-08080-2, JSC Design and Procedural Standards

- a. any breakage from failure of disconnecting device shall occur on discarded module
- b. isolation valves on retained module shall function even if separation system fails
- c. FTS preclude unacceptable loss of fluid after disconnection and include provisions to enable successful reconnection

[NASA SVS | Robotic Refueling Mission](#)

Ref 3.11-1

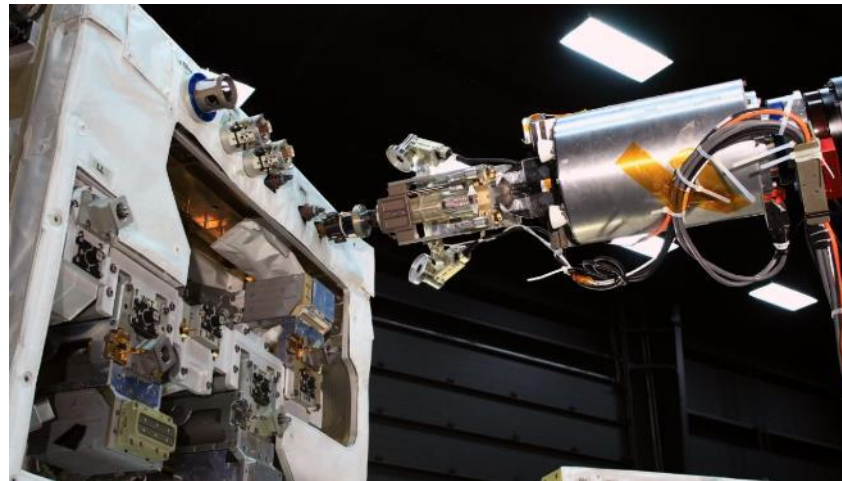

Fluid Transfer Couplings and Transfer System Lessons Learned and Hazards Need to be addressed

## 3.12 Filters and Filtration

### 3.12.1 Identification of Sources and Quantities of Contamination (**Guidance from NESC-RP-19-01498, Filtration of Spaceflight Propulsion and Pressurant Systems**) ref 26-1

[PSR-247G] = sources of particulate contamination and NVR shall be identified, quantified, and controlled, the purpose of location/sizing/selection of filters, including

[PSR-247aG] = contamination built into the piece-parts and components

[PSR-247bG] = manufacturing and assembly/integration operations, including the cutting and welding

[PSR-247cG] = fluids used during manufacturing, cleaning/flushing, assembly/integration, ground testing, servicing/deservicing, and maintenance

[PSR-247dG] = self-generated by the cyclic operation of components

[PSR-247eG] = degradation of softgoods

[PSR-247fG] = lubricants

[PSR-247gG] = Contamination that is trapped in 1-G in section of lines or components but then released in zero-g

[PSR-248G] = accumulation on the screens shall be quantified via contamination analysis to serve as an input to quantifying sources and the PMD flow/delta P analysis

### 3.12.2 Sensitivity to Contamination

[PSR-249G] = shall be assessed by generating a full list of the minimum orifice diameters, minimum clearances between moving parts, sealing surface materials

[PSR-250G] = sensitivity (e.g. valve response time and cycle life, internal/external leakage, flow control orifice dimensions, etc.) shall be evaluated by test if no data

[PSR-251G] = sensitivity of monopropellant decomposition to the presence of particulate contamination within the lines, filters, components shall be evaluated by test

[PSR-252G] = sensitivity of particle impact ignition within the oxidizer lines and components of a human rated spacecraft propulsion system shall be evaluated by test

### 3.12.3 Incorporation of Filters

[PSR-253S] = shall protect from particulate contamination in zero-gravity or reverse flow situations, backflow, either flow direction per F-29 in JSC-08080-2

[PSR-254G] = shall include filter on the flight side on the GSE interface just downstream of the coupling

[PSR-255G] = filters upstream and downstream of any pyro valve

[PSR-256G] = system filters shall be located downstream of all pressure vessels

[PSR-257G] = FOD screens shall be used if a large size part may be shedded in the failure of an upstream component

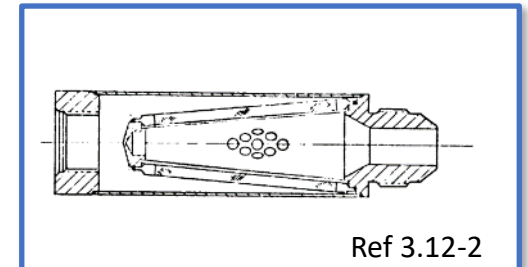

Filter Standards are missing (it was in shuttle program and specification documentation).  
Guidance Document NESC-RP-19-01498, Filtration of Spaceflight Propulsion and Pressurant Systems

## 3.12 Filters and Filtration

### 3.12.4 Filter Specification, Qualification, and Acceptance Test Requirements

[PSR-258G] = shall follow the design process described in [NASA Engineering and Safety Center \(NESC\) Technical Bulletin No. 22-02](#)

- a. define elements and cleanliness upstream of filter
- b. determine multiplying factor for lifetime
- c. determine particle decay rate
- d. total the particles
- e. convert to test dust
- f. determine allowable pressure drop
- g. determine required dirt holding capacity
- h. Specify the margin; 4x considered minimally acceptable for human spaceflight applications

[PSR-259G] = shall meet the intent of [NESC-RP-19-01498, Filtration of Spaceflight Propulsion and Pressurant Systems](#)

[PSR-260G] = Fluid filters used in a spacecraft propulsion system shall be constructed from wire cloth or etched disc

[PSR-261G] = Filter specification: Appendix I. Filter Requirements in [NESC-RP-19-01498, Filtration of Spaceflight Propulsion and Pressurant Systems](#)

[PSR-262G] = X-ray or visual inspection for FOD built into assembled filters (such as weld spatter or nodules)

[PSR-263G] = shall include fluid flow testing to quantify pressure drop and structural capability at the maximum specified dirt capacity and worst-case fluid flowrates

[PSR-264G] = Filters shall be tested at the system level under surge/transient conditions, including those that could cause backflow, and then inspected for damage to assess element collapse pressure differential (ECPD)

[PSR-265G] = Filter performance assessment shall consider the effects of 0-G, which may be different than in 1-G due to inherent settling of particulate in filter housing

### 3.12.5 Alternate to the use of wire cloth and etched disc filters

[PSR-266G] = shall demonstrate through tests, such as wetted decomposition, and inspections that all sources of contamination are controlled and that system/component design are not sensitive to contamination that result in catastrophic failure modes

Elevate NESC-RP-19-01498, Filtration of Spaceflight Propulsion and Pressurant Systems to shalls

## 3.13 Pyrotechnic Valves

### 3.13.1 Normally Closed (NC) Parent Metal Hermetic Sealing vs. Normally Open (NO)

[PSR-267S] = NASA-SPEC-5022, NASA Manufacturing and Test Requirements for Normally Closed (NC) Pyrovalves for Hazardous Flight Systems Applications

[PSR-268G] = Normally Open (NO) pyro valves shall provide a positive means of permanently isolating sections when activated

### 3.13.2 General Requirements for Pyro Valves

[PSR-269S] = shall meet the requirements of JSC 62809, Human Rated Spacecraft Pyrotechnic Specification

[PSR-270S] = shall feature NASA Standard Initiators (NSIs) that meet the requirements of JSC 28596, NASA Standard Initiator User's Guide

[PSR-271S] = shall meet the requirements of NASA-STD-8719.12, Safety Standard for Explosives, Propellants, and Pyrotechnics

[PSR-272G] = shall avoid the use of Titanium in pyro valve bodies/housings, and aluminum and its alloys as materials of construction in pyro valve primer chamber assemblies

[PSR-273S] = NC shall meet the requirements of NASA-SPEC-5022, NASA Manufacturing and Test Requirements for Normally Closed Pyrovalves

[PSR-274G] = NO shall meet tailored requirements of NASA-SPEC-5022, NASA Manufacturing and Test Requirements for Normally Closed Pyrovalves

[PSR-275G] = shall avoid situations where the inlet and outlet are both wetted with liquid propellant upon activation/firing

[PSR-276G] = qualification testing shall include actuation of the pyro valve after exposure to all relevant environments and operating conditions; attributes:

- Use of a flight-representative pyro device, firing circuit, and power source elements
- Use of a flight-representative mounting configuration for the pyro valve and interfacing tubing
- Use of ground test instrumentation to characterize the pyro shock on the interfacing tubing
- Evaluation of worst-case command timing for the firing of redundant pyro devices containing
- Evaluation of worst-case command timing for the actuation of redundant pyro valves containing
- Exposure to flight-representative environmental conditions and fluid commodities, including
- Evaluation of worst-case pressure transients resulting from the actuation of all pyro valves

National Aeronautics and Space Administration

**NASA Engineering and Safety Center Technical Bulletin No. 23-01**

### Including Key Design Features in Safety-Critical Pyrotechnic Firing Circuits

Pyrotechnic systems often fall into a unique category in that inadvertent activation of these systems resulting from a fault and/or lack of safe margins can lead directly to loss of crew. For example, untimely activation of pyrotechnics used for a flight termination system could override an abort capability. Over the years, NASA and the military have learned lessons about safe pyrotechnic circuit design and test, many of which are codified [1][2][3][4]. However, with NASA's recent efforts to move toward a development model that leans more heavily on Commercial Partners, these requirements have not always been directly levied on projects, and in some cases have been misinterpreted. This bulletin describes key safety features of pyrotechnic firing circuit design and provides rationale for inclusion of each feature.

Ref 3.13-1

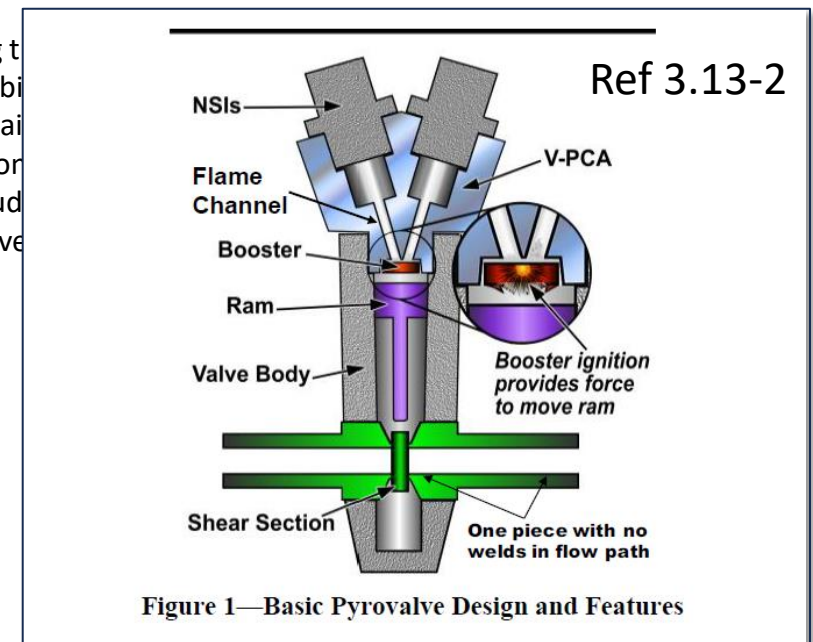

# 3.14 Thin Wall Flexible Pressure Boundary

## 3.14.1 TWFPB Failure Mode and Effects Analysis

[PSR-277G] = shall establish the criticality and identify any zero-fault tolerant, non-isolatable or non-detectable, failure modes of TWFPB hardware items and its effect

## 3.14.2 TWFPB Design, Analysis, and Test Requirements

[PSR-278S] = TWFPB that are zero fault tolerant to catastrophic hazards and not able to meet the requirements of NASA-STD-5019, shall comply with JSC-67035

## 3.14.3 Flow Induced Vibration

[PSR-279G] = flexible line segments and flexhoses used in the fluid lines of a human rated spacecraft propulsion system shall comply with the requirements of MSFC-SPEC-3746

Bellows Application	Failure or Damage Cause (s)	JSC 67035 Section 5.0 BP&G Matrix Table
Apollo CM RCS isolation valves	<ul style="list-style-type: none"> <li>Plastic deformation due to unexpected surge pressure during inadvertent operation</li> </ul>	<ul style="list-style-type: none"> <li>Note: MDP includes water hammer and needs to cover all operational scenarios, Proof is now 1.5x MDP,</li> <li>1.1 Increased margin of &gt;1.1 over plastic deformation</li> <li>1.11 – System dynamic interactions, water hammer, valve operations</li> </ul>
ISS ammonia system FDQC	<ul style="list-style-type: none"> <li>Leak cause unknown; suspect location is flexhose or valve bellows (both TWFPB),</li> <li>Leak grew in flight indicating cyclic load opening leak site</li> </ul>	<ul style="list-style-type: none"> <li>Failure and Cause Unknown, However BP&amp;G would be useful provide Objective Data since hardware still on-orbit (Future Exploration paradigm)</li> <li>1.11 – Interaction of bellows with system operations</li> <li>3.2 – Post proof test bellows inspection including CT at sub-assembly and component level</li> </ul>
OMS/RCS AC motor valve	<ul style="list-style-type: none"> <li>Complex design with torsional motion and need for a Krytox fill to pass proof test,</li> <li>Weld Porosity resulting in propellant leakage</li> <li>Prop leakage due to fatigue of deformed bellows</li> <li>No post proof NDE to detect deformed bellows</li> </ul>	<ul style="list-style-type: none"> <li>1.1 Increased margin of 1.1x proof over plastic deformation</li> <li>1.6 Axial motion of bellows is preferred</li> <li>3.2 Post proof NDE for plastic deformation and porosity</li> <li>4.1-4.4 Process controls – emphasis on cleanliness at all steps</li> </ul>
Latch isolation valves	<ul style="list-style-type: none"> <li>Deformed bellows, plastic deformation at proof for some bellows – variable unit-to-unit</li> <li>Tungsten inclusions</li> </ul>	<ul style="list-style-type: none"> <li>1.1 Increased margin of 1.1x proof over plastic deformation</li> <li>3.2 Post proof NDE for plastic deformation and porosity</li> <li>3.4 Lot testing addresses Supply chain consistency and visibility</li> <li>4.1-4.4 Process controls – weld quality</li> </ul>
MPS GHe crossover valves	<ul style="list-style-type: none"> <li>Excessive cycles because not properly spec'd for how operated (pressure vs. actuation)</li> <li>Internal Pressure applied to bellows</li> <li>Process changes in bellows manufacturing (plating procedure not well controlled and no insight)</li> </ul>	<ul style="list-style-type: none"> <li>1.2 BP&amp;G requires 10X life</li> <li>1.5 External Pressurization preferred</li> <li>1.11 System/Component Interaction - pressure interactions with system</li> <li>3.2d Spring rate test, etc</li> <li>4.1-4.4 Process controls 3.4 Lot testing addresses Supply chain consistency and visibility</li> </ul>
MPS GHe regulator	<ul style="list-style-type: none"> <li>Dynamic Instability at bellows natural frequency caused rapid failure</li> </ul>	<ul style="list-style-type: none"> <li>1.11 – Interaction of bellows with system operations</li> </ul>
RCS manifold bellows leak	<ul style="list-style-type: none"> <li>Porosity, intermittent leakage was confirmed downstream of the bellows</li> </ul>	<ul style="list-style-type: none"> <li>3.2 Post proof NDE (100%) CT for plastic deformation and porosity</li> <li>3 all – focus not just on bellows but bellows assembly – weld of bellows to end fittings</li> <li>4.1-4.4 Process controls – emphasis on cleanliness at all steps</li> </ul>
OMS fuel feedline bellows	<ul style="list-style-type: none"> <li>First weld union downstream of the 3<sup>rd</sup> bellows failed a mass spec leak check (8.6 x 10<sup>-4</sup> sccs vs. required 1 x 10<sup>-4</sup> sccs</li> <li>Weld pore (0.030" x 0.015"), inadequate weld fusion</li> </ul>	<ul style="list-style-type: none"> <li>3.2 Post proof NDE (100%) CT for plastic deformation and porosity</li> <li>3 all – focus not just on bellows but bellows assembly – weld of bellows to end fittings</li> <li>4.1-4.4 Process controls – emphasis on cleanliness at all steps</li> </ul>
Orbiter PRCS Direct Acting Valve (DAV)	<ul style="list-style-type: none"> <li>fatigue failure resulting in internal leakage and fuel valve fail closed</li> <li>a fatigue crack driven by external pressure cycles and malformed weld bead</li> </ul>	<ul style="list-style-type: none"> <li>1.1-1.11 design margins</li> <li>2.0 NASA or prime Independent analysis</li> <li>3.1 Development Test screened for inadequate design</li> <li>3.2 Post proof NDE (100%) CT for plastic deformation and geometry issues</li> </ul>

Fig. 8 -0006 regulator model.

Fig. 13 Video of the bellows at 960 Hz and 890 Hz.

### Shuttle MPS GHe Regulator

- Failure of Sealed Reference pressure bellows caused full open failure of regulator resulting in loss of GHe to SSME to purge pump seal cavity
- Failure due to regulator instability
- Solution was to redesign regulator sense orifices and vent the bellows and make adjustment to compensate for ambient to vacuum reference

Ref 3.14-1

## 3.15 Spacecraft Engines and Thrusters

### 3.15.1 Heritage Engines and Thrusters

[PSR-280G] = Define Operating and Qualification Box

[PSR-281G] = heritage engines shall require design and qualification to the standards and requirements herein JSC 67723

### 3.15.2 Strength and Life Requirements

[PSR-282S] = Gas or Liquid engines shall comply with NASA-STD-5012 Rev B, Strength and Life Assessment Requirements for Liquid-Fueled Space Propulsion System Engines

[PSR-283SC] = Pump-fed: min. of four (4) EDUs and two (2) qual units, each 2x on service life duration, 1.1x on max single burn or profile duration, and 4x\* on total burn count

Rationale: clarifies SMC-S-016, SMC-S-025, and NASA-STD-5012

[PSR-284SC] = Bi-Prop Pressure-fed: min. (1) (EDU) and one (1) qual, each min. 2x on service life duration, 1.1x on max. single burn or profile duration, and 4x\* on total pulses

[PSR-285SC] = Monoprop: one EDU) and one qual, each demo a min factor of 2x on service life duration, 1.1x on maximum single burn duration, and 4x\* on total pulse count

[PSR-286G] = Qualify by test the number of cold and hot restarts

[PSR-287G] = Qualify by test 4x Deep Thermal Cycles

[PSR-288G] = Measure transient overpressures with high-speed instrumentation and apply factors per 3.5.1.2 Dynamic

[PSR-289SC] = Proof and Burst tests shall include transient overpressures per test factors in NASA-STD-5012 Table 1 and

[PSR-290SC] = Engines/thrusters in their final state of assembly for delivery shall undergo a hot-fire ATP per NASA-STD-5012

### 3.15.3 Reusable Engines

[PSR-291G] = accounting for actual usage, inspections, qualified minimum remaining life for the next mission, where p

[PSR-292G] = inspections shall include effects from environmental exposure (ie saltwater), chamber wear, injector we

### 3.15.4 Evaluation and Test Requirements for Liquid Rocket Engines (SMC-S-025 and SMC-S-016)

[PSR-293SC] = Spacecraft propulsion systems of any thrust level, gas or liquid prop shall comply with the requirements

[PSR-293a] = Sections 4.5, 4.6, 5, and A.1 shall be superseded in their entirety.

[PSR-293b] = min engine samples in Table 4-1 shall be increased from 4 to 6

[PSR-293d] = pressurant and propellants shall be per flight procurement and usage specs

[PSR-293e] = propellant feed lines used for qual and ATP testing of all engines shall be of flight representative i

[PSR-293f] = TWFPB that are part of the flight propellant feed system design, whether on the veh. Interface or

[PSR-293g] = flight electrical circuits used to provide power and switching for engine components (e.g. valves,

[PSR-293h] = If pneumatically driven, pneumatic pressure/temperature allowable ranges and the flight pneum

[PSR-293i] = Teardown and inspection of the engine to identify unexpected conditions, areas of excessive wear, and/or incipient hardware failure shall be performed

[PSR-293j] = All testing shall include the monitoring for combustion instability thru either pressures or accelerometer that have been calibrated to detect instability

#### Note:

Specified 4x on burns / pulse count due to:

- large variation in operating conditions,
- difficultly to define MDC and perform life analysis,
- engine variability,
- small number of engine samples.

SMC-S-025 Has some necessary Requirements, but need to deconflict with NASA-STD-5012

## 3.15 Spacecraft Engines and Thrusters

### 3.15.1.4 Evaluation and Test Requirements for Liquid Rocket Engines (SMC-S-025 and SMC-S-016)

[PSR-294G] = scope of testing shall include all sections of SMC-S-016 in addition to engine/thruster level hot fire testing

[PSR-295G] = shall perform run-to-depletion tests for both bipropellants (simultaneous and staggered) or monopropellants to assess failure mode and hazards

### 3.15.5 Delta- Qualification

[PSR-296G] = If the allowable range of engine operation is outside of general heritage range of proven qual and flight operation, then engine delta-qualification testing shall include moderate accumulated operational duration at extremes of inlet pressures (in terms of allowable MR variation, thrust level range, etc.), duty cycle, duration and transient operation (fuel/ox start-up and shut-down lead lag testing), where moderate accumulated operational duration consists of 10% of required life at each extreme of operational conditions or mission representative testing with a factor of 2 for allowable extremes of operation.

### 3.15.6 Combustion Stability

[PSR-297S] = shall implement the recommendations contained in JANNAF-GL-2022-0001 Guidelines for Combustion Stability Specifications and Verification Procedures

[PSR-298G] = engine/thruster hot fire testing shall be conducted with a flight-representative feed system and an enveloping range of operating conditions

### 3.15.7 Thermal Limitations and Control

[PSR-299G] = thermal interface, including the interaction with other engines and environment, and TCS (heaters, insulation, or heat rejection) shall be defined

[PSR-300G] = thruster safe operating thermal limitations shall be defined through testing by mapping the mission duty cycle %, pulse width, duration, and environ. conditions.

### 3.15.8 Engine/Thruster Ignition Systems

[PSR-301S] = High voltage electrical spark ignition systems/equipment shall comply with the 'problem electrical components' requirements of paragraph E-7 in JSC-08080-2

### 3.15.9 Overpressures; Control of hardstarts, ZOTs, and Pops (generic to any propellant combinations) → MDP

[PSR-302G] = pressure transients associated with accumulated propellants and FORP/explosive mixture formation during the engine start, steady-state, shutdown transients shall be measured using high speed instrumentation in the chamber and manifolds under the full range of mission duty cycle profiles, hardware and propellant temperature, and include valve lead-lag variation within tolerances, Ghe saturation, poppet travel times, valve variability, temperature

[PSR-303G] = The minimum allowable time for safe engine restart that allows the accumulated propellant mixture or FORP to evaporate after a pulse shall be verified by test under the full range of TLYF conditions.

[PSR-304G] = The minimum electrical pulse width, duty cycle%, and duration shall be characterized thru testing to establish regions of operation where the injector temperature decreases due to evaporative cooling of propellant in the injector dribble volume below qualified levels. (*cold ratcheting*)

[PSR-305G] = Material compatibility assessments shall include the consideration of high pressure and high temperature events that could lead to combustion of metal parts with the propellant oxidizer or damage of the chamber. (ie titanium injectors and manifolds with ZOTs)

Combustion Stability per JANNAF-GL-2022-0001. Need to Measure Injector and Chamber Pressure Transients (MDP/MEOP)

## 3.15 Spacecraft Engines and Thrusters

### 3.15.10 Engine and Valve Leak Detection

[PSR-306G] = Leak detection of an engine, for any propellant type, shall be implemented.

[PSR-307G] = Sensitivity of the engine leak detection system or method(s) shall be determined by test

[PSR-308G] = For evaluation of catastrophic hazards, an engine or thruster valve shall be assumed that it can develop a leak, without having been actuated, due to inlet pressure changes such as water-hammer, thermal cycles, or seal degradation and swell

### 3.15.11 Thrust Vector Control (TVC)

[PSR-309S] = The TVC mechanism shall meet all requirements in NASA-STD-5017 for design, analysis, and test, including best practices in Appendix A.

[PSR-310G] = The TVC system shall be 1FT as a minimum to catastrophic loss of control.

[PSR-311G] = TVC actuators shall be capable of holding engine position in the event of loss of power and with maximum forces produced by engine thrust and other disturbances

[PSR-312G] = 1FT design shall contain features which provide full electrical and mechanical redundancy through the output attach point on the driven engine/thruster

[PSR-313SC] = In lieu of fault tolerance, TVC primary structure shall meet the requirements of JSC 65828 and JSC 68529.

[PSR-314G] = TVC position measurements shall be redundant with voting logic and sensor fault detection.

[PSR-315G] = The TVC system shall report faults and results of built-in-tests.

[PSR-316S] = TVC system shall meet the engine level test requirements per SMC-S-025 Section 7.3.9, with the added clarification that 7.3.9-6 includes the mission cycles and durations for vacuum operation and exposure.

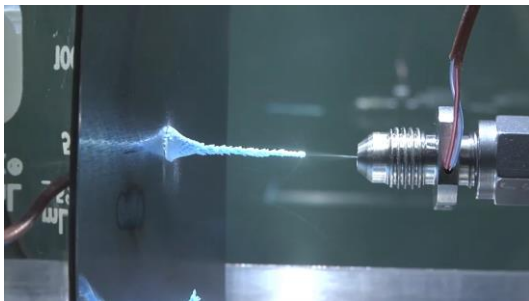

N2O4 leaks in a vacuum may freeze and can cause flow blockage in engines (Ref 3.15-1)

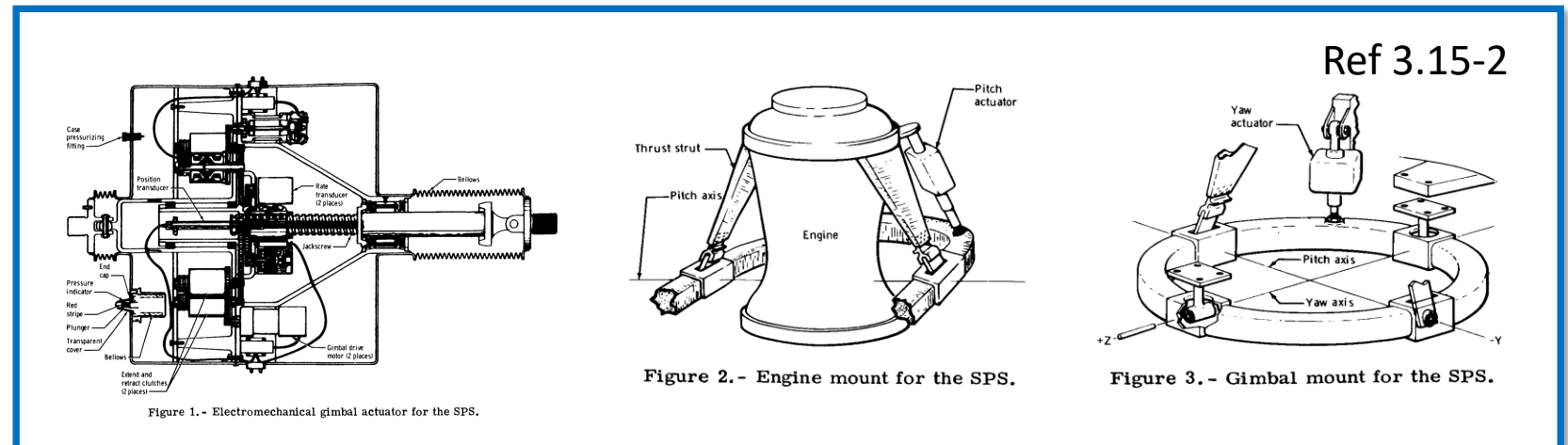

Need Leak detection for engines. Need TVC fault/hazard requirements and SMC-S-025 for TVC testing

## 3.16 FDIR, Instrumentation, Data Rates, and Software

### 3.16.1 Fault Detection Isolation and Recovery (FDIR)

[PSR-317G] = propulsion system shall provide the capability to detect, announce, and transmit to the ground faults and to isolate and recover from faults

[PSR-318G] = Detect, isolate and recover from failure modes and hazards identified during system design, development, or mission operations within the time limit necessary to mitigate the catastrophic failure

[PSR-319G] = shall incorporate dissimilar instrumentation or possess secondary cues to establish the validity of instrumentation that used for the diagnosis and control a catastrophic hazard

[PSR-320G] = In addition to FDIR, the propulsion system instrumentation shall provide sufficient health and status insight to support flight anomaly resolution and failure event reconstruction.

[PSR-321G] = When a measurement is critical to controlling a catastrophic hazard, the measurement shall be a direct fluid pressure, temp., or position of the valve or inhibit.

[PSR-322G] = Instrumentation that is wetted by propellants shall be examined for hazard criticality and failure/fracture

[PSR-323G] = FDIR software shall screen for instrumentation failures that are OSL/OSH and also correct for bias/offsets.

### 3.16.2 Instrumentation Data Rates

[PSR-324G] = shall be sufficient to ensure that in-flight FDIR operations can be accomplished successfully within the worst-case time-to-effect

[PSR-325G] = combustion chamber pressure ( $P_c$ ) measurements or engine thrust level detection shall capture at least three (3) data samples during the minimum EPW

### 3.16.3 System Leak detection – Internal and External

[PSR-326G] = shall incorporate a minimum of one pressure transducer in each isolatable section of the propellant delivery system

[PSR-327G] = shall employ a combination of system-level and localized leak detection methods to identify unallowable leakage

[PSR-328G] = method for detecting external leakage of non-isolatable bulk propellant shall be included

### 3.16.4 Instrumentation Types

[PSR-329G] = RTDs shall be used for critical temp sensing in propulsion systems.

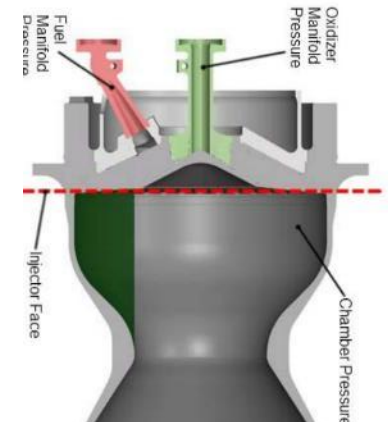

Shuttle Primary RCS had wire wrap to detect burn-thru due to instability



Ox leak caused explosion in fuel manifold

Ref 3.16-1

## 3.17 Propulsion System Electrical

### 3.17.1 Protective Covers

[PSR-330S] = shall comply with the 'protective covers or caps' requirements of paragraph E-11 in JSC-08080-2

### 3.17.2 Electrical Bonding

[PSR-331S] = shall comply with the electrical bonding requirements of NASA-STD-4003, Electrical Bonding

### 3.17.3 Propulsion Device Power Switching

[PSR-332G] = shall provide single-fault tolerance to inadvertent application of power, using independently-controlled series-redundant switches, min. 1 on high side

### 3.17.4 Corona Suppression

[PSR-333S] shall meet the 'corona suppression' requirements of paragraph E-6 in JSC-08080-2

### Gemini 8 OAMS

- Thruster 8 switch on the ground side.
- Ground short caused stuck on thruster.

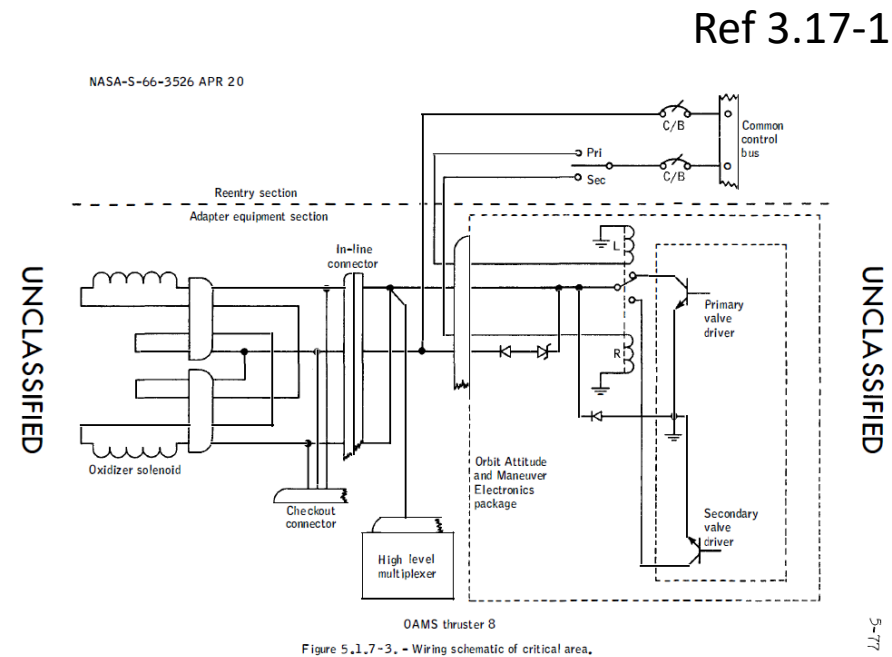

# 3.18 Flight and Ground Operations Interface

## 3.18.1 Flight Operations

- [PSR-334S] = Tracking of time and cycle exposure per G-10 in JSC-08080-2
- [PSR-335G] = Documentation shall include propulsion-related content under configuration
  - a. Launch Commit Criteria (LCC)
  - b. Flight Rules (FR)
  - c. Telemetry lists
  - d. Integrated schematic diagrams relating fluids, power, and instrumentation
  - e. Minimum Equipment List (MEL)
  - f. Powered Equipment List (PEL)
  - g. Console handbooks and associated online databases

[PSR-336G] = reserved for crew insight to propulsion anomalies when ground delay does not occur

## 3.18.2 Flight Hardware -to-Ground Interface Protections

- [PSR-337G] = ground test facility shall have a general operating procedure manual with specific instructions
- [PSR-338S] = Procedures, including any interfacing equipment, shall comply with the 'hazardous operations' requirements of paragraph G-24 in JSC-08080-2
- [PSR-339S] = shall comply with the 'verification test provisions' requirements of paragraph G-24 in JSC-08080-2
- [PSR-340G] = ICD requirements shall define the propulsion system fill rates, pressurization, and venting (etc) limits
- [PSR-341G] = flight hardware shall be monitored and protected with 1 fault tolerance, against over-pressurization, over-voltage, over current, over temperature, vibration or shock
- [PSR-342G] = shall be protected against back emf, back flow of fluids including contamination, or back pressure.
- [PSR-343S] = shall comply with the 'protecting flight equipment' requirements of paragraph G-24 in JSC-08080-2
- [PSR-344G] = Filters at the interface between GSE and the vehicle shall be installed and verified on the GSE side near the QD
- [PSR-345G] = GSE Filter Qualification shall be in accordance with the flight filter specification as to the maximum particulate rating
- [PSR-346G] = Acceptance of each GSE/Vehicle interface and final filter shall be accomplished by the test method of ARP 961 to the bubble point test
- [PSR-347G] = Certification of each interface filter disconnect assembly cleanliness shall be according to ARP 599A to the subsystem cleanliness level Specified
- [PSR-348G] = The initiation/termination of fluid flow during propellant transfer operations shall rely on valves in the propulsion system design rather than QDs

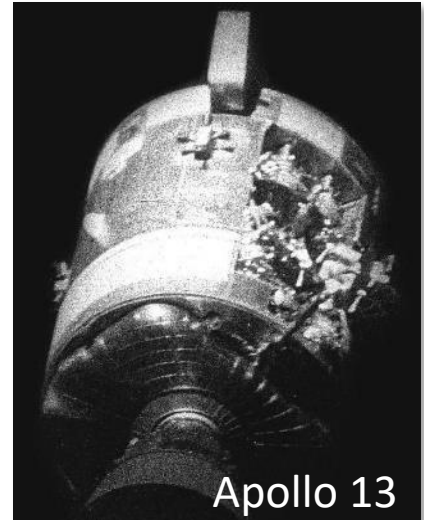

Apollo 13

**Tank was dropped several inches. Heaters were left on continuously due to failed thermostat. Thermostat was not rated for voltage applied. Damaged wire insulation inside O2 tank.**  
 Ref 3.18.2-1



- 1) Iron nitrate jammed QD
- 2) GSE was not isolated in procedure
- 3) NTO spilled onto Shuttle Tiles



**Titan II: Teflon Jammed QD Poppet. Two ground crew killed**  
 Ref 3.18.2-2

## 3.18 Flight and Ground Operations Interface

### 3.18.2 Flight Hardware (FH) -to-Ground Interface Protections (continued)

[PSR-349S] = Ground fluid servicing and test port connections shall comply with the 'prevention of incorrect connection' requirements of paragraph F-3 in JSC-08080-2,

[PSR-350SC] = The fluid 'quick disconnects' shall comply with the requirements of the following paragraphs in NASA-STD-8719.24, NASA Payload Safety Requirements:

- Paragraph 12.1.10.2.3.4, which addresses self-sealing design features, internal/external leakage performance at high and low pressure, and cryogenics
- Paragraph 12.1.10.2.3.5, which addresses bi-directional flow capability.
- Paragraph 12.1.10.2.3.6, which addresses external leakage during mating and demating.
- Paragraph 12.1.10.2.3.9, which addresses external leakage and inadvertent demating when exposed to externally applied loads.
- Paragraph 12.1.10.2.3.10, which addresses the loads imparted to interfacing fluid lines during mating and demating.
- Paragraph 12.1.10.2.3.11, which addresses design features to avoid inadvertent mating of disconnects carrying incompatible fluids.

[PSR-351G] = Spacecraft propulsion system design shall allow for it to be drained and decontaminated during contingency ground operations

[PSR-352S] = Gases used for purging propellant vapors from spacecraft compartments shall meet the 'dew point' requirements of paragraph F-21 in JSC-08080-2

[PSR-353S] = Ground electrical connections shall comply with the 'prevention of incorrect connection' requirements of paragraph E-1 in JSC-08080-2,

[PSR-354S] = The GSE and spacecraft shall comply with F-12 Protection of Pressurized Systems from Damage Due to Pressurant Depletion – Support Equipment.

### 3.18.3 Hardware Warning Signs and Labels

[PSR-355S] = direction of fluid flow for proper operation in the system shall comply with the 'design, marking, and testing' requirements of paragraph F-8 in JSC-08080-2

[PSR-356S] = shall comply with the 'product identification and marking' requirements of paragraph G-22 in JSC-08080-2

[PSR-357S] = shall be classified, identified/tagged, and controlled in accordance with the requirements of JPD 7120.14, Spaceflight Hardware Classification and Control.

[PSR-358S] = shall have color codes, labels or warning signs, and directional arrows to identify hazards and direction of flow per NASA STD-8719.24B req ?

[PSR-359S] = shall comply with the packaging, handling, and transport (PH&T) requirements of NPR 6000.1, Requirements for Packaging, Handling, and Transportation

Injuries at KSC and WSTF occurred due to design that allowed the ¼ inch coupling to be mated to ½ inch coupling and actuate the poppet

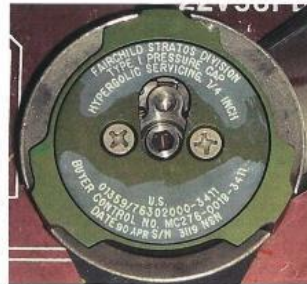

Figure 11: Fairchild 1/2-inch Flight Cap

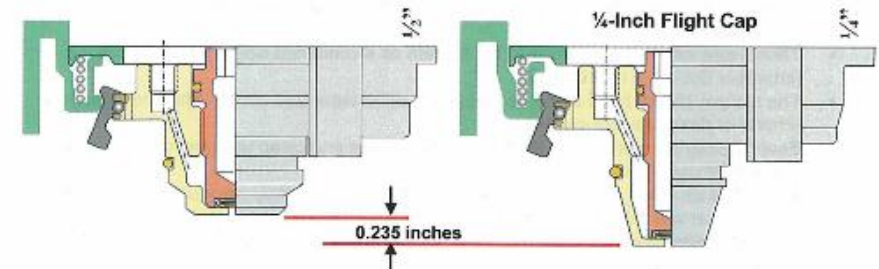

Figure 30: 1/4-inch and 1/2-inch Hypergolic Flight Cap Cutaway View

Ref 3.18.2-3

# Conclusion

- Lesson Learned provide key rationale for the requirements
  - Great Input from NESC TDT members
  - NASA Lesson Learned database is a valuable tool
  - Lesson Learned and experience reports by the engineers are critical
  - NESC Technical Reports and Bulletins are a backbone to improvement to technical standards
- JSC 67723 identifies the existing standards that apply to human rated propulsion systems and more importantly provides clarification and gaps, based on lessons learned, that are needed to control catastrophic hazards
- Forward Plan
  - Releasing document as a baseline that is publicly available
  - Conducting an Industry TIM and gathering industry feedback will help strike an appropriate balance of competing cost/schedule/technical aspects without sacrificing safety
  - Planning Update and release as a rev A in August timeframe

# References

- (ref 3.1.9-1) page 2 in “Slosh Anomaly in Apollo Lunar Module Propellant Gage (Scholl, 1971), [19710028365.pdf](#)
- (ref 3.1.9-2) Apollo 11 Mission Anomaly Report No. 3 Service Module Entry (McDivitt, 1970), [ntrs.nasa.gov/api/citations/19710017109/downloads/19710017109.pdf](#)
- (ref 3.1.12-1) [Boeing CST-100 Starliner Pad Abort Test | NASA Image and Video Library](#)
- (ref 3.1.14-1) Donald D. Arabian, J. E. Apollo 15 Main-Parachute Failure. Houston: NASA - JSC. (1973). [Apollo 15 main-parachute failure - NASA Technical Reports Server \(NTRS\)](#)
- (ref-3.1.14-2) page 18 in KSC-2010-045R, Hypergolic Propellants: The Handling Hazards and Lessons Learned from Use ([https://ntrs.nasa.gov/citations/20100042352](#)
- (Ref 3.2.2-1) LLIS-1196 Test as You Fly, Fly as You Test, and Demonstrate Margin (1998) [https://llis.nasa.gov/lesson/1196](#)
- (Ref 3.2.5-1) SSC20210116\_GR9312 | NASA Image and Video Library
- (Ref 3.2.5-2) page 2 Martinez, H. E. (2011). Lessons Learned from the Design, Certification, and Operation of the Space Shuttle Integrated Main Propulsion System (IMPS). Houston: AIAA. [https://ntrs.nasa.gov/api/citations/20110013223/downloads/20110013223.pdf](#)
- (Ref 3.3.5-2) AFRL-RZ-ED-TP-2008-184 Nitrous Oxide Explosive Hazards [14 December 2007](#)
- (ref 3.3.6-1) page 25 in Hernandez, F. J. (2011). Selected Lessons Learned in Space Shuttle Orbiter Propulsion and Power Subsystems. Houston: NASA [https://ntrs.nasa.gov/api/citations/20110015485/downloads/20110015485.pdf](#)
- (Ref 3.4.3-1) Page 27 Nufer, B. (2010). HYPERGOLIC PROPELLANTS: THE HANDLING HAZARDS AND LESSONS LEARNED FROM USE. KSC: NASA. [KSC-2010-045R.pdf](#)
- (ref 3.4.8-1) Mars Science Laboratory (MSL). Fabrication of Propulsion Tubing for the MSL Descent Stage [https://llis.nasa.gov/lesson/14201](#)
- (ref 3.5.1-1) [Treatment of Transient Pressure Events in Space Flight Pressurized Systems - NASA Technical Reports Server \(NTRS\)](#)
- [\(ref 3.6.3\) NESAC Technical Bulletin 19-02, 90/95 POD Radiography Concern for COPVs and Metal Tank Welds.](#)
- (Ref 3.6.6) Orbiter OMS and RCS technology (Boudreaux, 1983) [\(ref\)](#) Page 6 and 21. Shuttle OMS and RCS tank retention safety factors
- (Ref 3.7.1-1) [ref](#) page 2 Hurlbert, E. (1990). *Methods used to investigate and resolve the Space Shuttle helium pressure regulator instability*. AIAA 90-2749.
- (Ref 3.7.3) Guernsey, C. S., 2001, "Propulsion lessons learned from the loss of Mars Observer", [https://hdl.handle.net/2014/36825](#), ['37th AIAA/ASME/SAE/ASEE Joint Propulsion Conference', 'Salt Lake City, UT, USA'], JPL Open Repository; 01-1441.pdf , Mars Observer spacecraft, reference ([LLIS-485](#)) Isolate the Propulsion Pressurization System from the Propellant Tanks (LLIS-485, 1996). See also Juno Spacecraft, ([LLIS-28105](#)) High Oxidizer Vapor Content May Cause Vapor Reaction in Bi-Propellant Systems. (LLIS-28105, 2017).

# References

- (ref 3.8.3-1) page 25 in Hernandez, F. J. (2011). Selected Lessons Learned in Space Shuttle Orbiter Propulsion and Power Subsystems. Houston: NASA <https://ntrs.nasa.gov/api/citations/20110015485/downloads/20110015485.pdf>
- (ref 3.8.4-2) page 11 Martinez, H. E. (2011). Lessons Learned from the Design, Certification, and Operation of the Space Shuttle Integrated Main Propulsion System (IMPS). Houston: AIAA. <https://ntrs.nasa.gov/api/citations/20110013223/downloads/20110013223.pdf>
- (ref 3.9-1) page 3 and 7, NASA TN D-6740 Apollo Experience Report Lunar Module Reaction Control System. Vaughan, C. (1972). NASA-JSC. Houston: [19720014237.pdf](https://ntrs.nasa.gov/api/citations/19720014237/pdf)
- [\(ref 3.10.2-1\)](#) Skylab Mission Report Second Visit (Kleinknecht, 1974, pp. 17-4 to 17-10),
- [\(ref 3.10.2-2\)](#). “Lessons Learned from 50+ Years in Human Spaceflight and Safety,” (Johnson, 2018, p. 7). and (Nufer, 2010, pp. 36-41)
- [\(Ref 3.11-1\) NASA SVS | Robotic Refueling Mission](#)
- (Ref 3.12-2) [Shuttle filter study. Volume 1: Characterization and optimization of filtration devices - NASA Technical Reports Server \(NTRS\)](#)
- (Ref 3.13-1) [TB 23-01 Pyro Best Practices 031523.pdf](#)
- (Ref 3.13-2) Page 8 . NASA-SPEC-5022, NASA Manufacturing and Test Requirements for Normally Closed Pyrovalves. [2021-07-16\\_nasa-spec-5022\\_w-change\\_2\\_revalidation\\_w-edit-admin\\_chgs\\_final.pdf](#)
- (Ref 3.14-1) [ref](#) Hurlbert, E. (1990). *Methods used to investigate and resolve the Space Shuttle helium pressure regulator instability*. AIAA 90-2749. Page 30
- (Ref 3.15-1) page 1 “Study of propellant valve leakage in a vacuum Phase I report” Gift, 1966, <https://ntrs.nasa.gov/citations/19660008733>
- (Ref 3.15-2 NASA TN-7969; “APOLLO EXPERIENCE REPORT - GUIDANCE AND CONTROL SYSTEMS: CSM SERVICE PROPULSION SYSTEM GIMBAL ACTUATORS” William A. McMahon. Lyndon B. Johnson Space Center, Houston, Texas 77058, July 1975, <https://ntrs.nasa.gov/citations/19750017908>
- (ref 3.16-1) Failure Investigation of an Intra-Manifold Explosion in a Horizontally-Mounted 870 lbf Reaction Control Thruster. Durning, J. G. (2011). Houston: NASA-JSC.
- (Ref 3.17-1) pp 312-321, [NASA SP-4203](#), On the Shoulders of Titans: A History of Project Gemini. (Hacker, 1977, pp. 312-321)
- (Ref 3.18.2-1) page 10 [JS-2018-009, NNJ13RA01B](#) *Lessons Learned from 50+ Years in Human Spaceflight and Safety*. NASA JSC. Johnson, G. (2018).
- (Ref 3.18.2-2) page 11 KSC-2010-045R, Hypergolic Propellants: The Handling Hazards and Lessons Learned from Use (<https://ntrs.nasa.gov/citations/20100042352>
- (Ref 3.18.2-3) Page 16-17 at KSC, 42 at WSTF as referenced in KSC-2010-045R, Hypergolic Propellants: The Handling Hazards and Lessons Learned from Use (<https://ntrs.nasa.gov/citations/20100042352>