

# Development and Projected Capabilities of Chamber D

Stephen Baker<sup>1\*</sup> and Hunter Kuehnel<sup>2</sup>

<sup>1</sup> Johnson Space Center, NASA, Houston, United States

<sup>2</sup> JF12, Amentum, Houston, United States

\*E-mail: stephen.m.baker@nasa.gov

**Abstract.** Chamber D is a Thermal-Vacuum (TVAC) chamber that is currently being developed by the National Aeronautics and Space Administration (NASA) Johnson Space Center (JSC) Crew and Thermal Systems Division (CTSD) to simulate the environment of a lunar Permanently Shadowed Region (PSR). A gaseous helium cooled shroud is being integrated into a vacuum chamber. Chamber D is in the Space Environment Simulation Laboratory (ESL) which includes the large TVAC chambers, Chamber A and Chamber B. A liquid nitrogen thermosiphon and a helium refrigeration system are used to control the temperature of the Chamber A shrouds. Chamber A and Chamber B also use helium refrigeration to create the final high vacuum levels. In total, the ESL has a large helium refrigeration system (12.5 KW) to create the thermal environment in Chamber A and also has a separate smaller refrigeration system (3.5 KW) for cryopumping in both chambers. The smaller system that cools the cryopumping panels in Chamber A and Chamber B is being used to cool the gaseous helium-cooled shroud of Chamber D. As a result, Chamber D will have a significant refrigeration capacity relative to TVAC chambers of similar size. The development and projected capabilities of Chamber D will be discussed.

## 1. Introduction and History

The Space Environment Simulation Laboratory (ESL) located in Building 32 at JSC consists of two large Thermal-Vacuum chambers built in the 1960's to support the Apollo program, Chamber A and Chamber B. NASA and commercial partners have continued to develop technology that requires testing at increasingly colder environments. In 1996, the helium refrigerators with piston expansion engines were replaced with two 3.5KW refrigerator systems utilizing Linde model TCF50 cold boxes for the internal cryopumping capability. In 2008, the control system for helium trains were changed to a floating pressure control system based on the Ganni Cycle, among other improvements<sup>1</sup>. In 2012 a new large (12.5 KW) refrigeration system was commissioned in preparation of testing the James Webb Space Telescope in Chamber A. In 2017, the James Webb Space Telescope (JWST) TVAC test in Chamber A was able to achieve the required temperatures for the thermally simulated deep space test point. Since 2017, Chamber A has been used to test other large-scale spacecraft needing to simulate either deep space or lunar Permanently Shadowed Region (PSR) TVAC conditions. Thermal-vacuum testing needs continue to evolve.

The Systems Test Branch has identified testing needs including the simulation of thermal profiles such as deep space or lunar PSR environments for small scale technology. Recent

examples include Extravehicular Activity (EVA) hardware such as space suit boots, space suit gloves, tools, and component level hardware for the lunar and Martian surfaces. To avoid resorting to an oversized chamber, which would be resource intensive, the Systems Test Branch is developing a novel chamber which utilizes one of the helium trains in the SESL among other existing facility infrastructure.

## **2. Chamber Requirements**

The requirements for Chamber D were developed through collaboration with prospective test requestors and by evaluating the most extreme environmental conditions, including deep space and PSRs. Documented requirements prior to design include the following: average shroud temperature, shroud emissivity, chamber pressure, load capacity, the capability to add linear actuation for thermal contact testing. And instrumentation accuracy. Required instrumentation includes Residual Gas Analysis (RGA), Cryogenic Quartz Crystal Micro (CQCM), thermal imaging cameras, optical cameras, silicon diodes for test article temperature data, and silicon diodes for shroud thermal characterization, and full range vacuum instrumentation bounded by the lowest operating chamber pressure. Requirements were developed in collaboration with the relevant subject-matter experts and test requestors.

## **3. Thermal Control Approach**

In addition to achieving the target low temperature of 15 K, it is desirable for the Chamber D shrouds to have full-range temperature control between 15 K and 330 K. Some temperature control can be achieved near 15 K by powering the 3700 W return heater in Helium Train 1, however the extent of this control was unknown. During a system test on the TF50, the return heater was powered at various wattages to determine the maximum feasible temperature control range. As shown in Figure 1, there is control to approximately 50 K. To control temperature above 77 K, the working gaseous helium will be cooled by a liquid nitrogen heat exchanger rather than expansion and the return heater will be used to increase the temperature. To achieve thermal control in the range of 50 K to 77 K, modular thermal heaters internal to the chamber working area will be used.

The large 12.5 KW system was architected to be very flexible to control temperatures from 330 K to 15 K. The smaller TF50 3.5 KW systems were not designed for full thermal control, but as part of this project or possibly in the future after proving full cold capabilities, we are looking to modify the smaller refrigeration units to allow full thermal control of the Chamber D shroud from 330 K to 15 K.

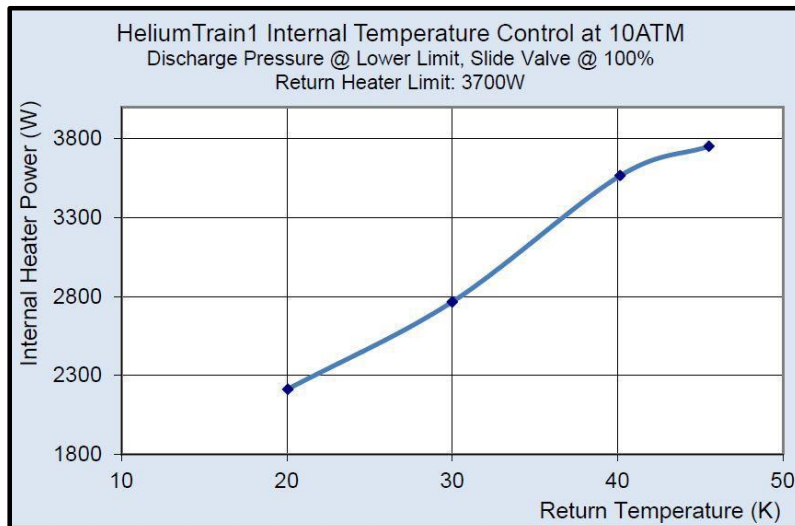

**Figure 1.** Low End Helium Temperature Control by Return Heater Power

#### 4. Projected Capabilities

The Chamber D working area will be a 35.75" diameter by 39.75" long horizontal cylinder with a 23.75" by 39.75" actively cooled flat platen. The chamber will have a single gaseous helium shroud which can achieve full range temperature control of 330 K - 15 K. Heater bars, infrared lamps, or heat tape may be used inside the working volume to achieve test article temperatures higher than 330 K. The refrigeration capacity at 20 K is 3.5 KW. A turbopump is used in addition to the shroud cryopumping to achieve a vacuum of  $10^{-8}$  torr. 4x vertical ASA 11.0 flanges are installed to allow for electrical, fluid, or mechanical passthroughs with removable passively cooled blinds on the shroud. The chamber is instrumented with silicon diodes to monitor shroud temperature and a full-range vacuum pressure sensor (cold cathode). The chamber will be instrumented with both optical and thermal imaging cameras. The integrated chamber is modeled in Figure 2.

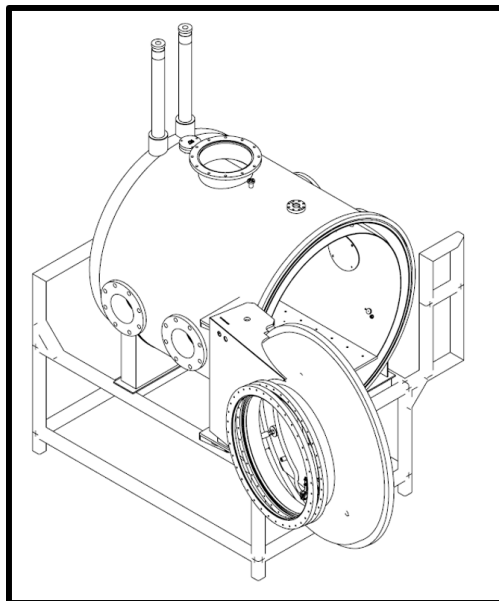

**Figure 2.** Integrated Chamber D Model

## **5. Forward Work**

The Preliminary Design Review for Chamber D was held April 24th, 2025. The preliminary designs and analyses were reviewed, and procurements were approved. The build and test of auxiliary hardware such as the instrumentation rack, control rack, and pressure systems are continuing. Chamber D will return from the vessel modification vendor in October 2025 and integration into the existing infrastructure and auxiliary hardware will begin. Project closeout and chamber functionality are expected in December 2025.

## **References**

- [1] Homan, J. et al, Floating Pressure Conversion of Two 3.5KW, 20K, Helium Refrigerators, *Advances in Cryogenic Engineering* 55B, 2009, pp. 1072-1077