



## Thermal Systems Engineering for Nuclear Electric Propulsion (NEP) High Temperature Radiators

Presented by: Will Grier



**THERMAL & FLUIDS**  
ANALYSIS WORKSHOP  
Ames Research Center 2025

**Will Grier** (LaRC-D206), **Amanda Stark** (LaRC-D206),  
**Diego Perea** (LaRC-D206, Intern, San Diego State University),  
**Tai Valdés** (LaRC-D312, Intern, Pennsylvania State University),  
**Malay Shah** (KSC-NEL60), **Sarah Czerwien** (GRC-LTT0, HX5),  
**William Macheimer** (Analytical Mechanics Associates [AMA]),  
**Andrew McMahon** (LaRC-D208)

**Thermal & Fluids Analysis Workshop 2025**  
**NASA Ames Research Center**

San Jose, CA  
August 4-7, 2025



# Outline

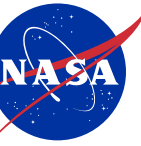

- Nuclear Electric Propulsion (NEP) Introduction
- Project Overview
- State of the Art (SoA) Comparison
- Target Application
  - Thermal Environments Modeling
- System Definition Diagrams
  - External Interfaces
  - Installation and Commissioning Options
  - Internal Interfaces
  - Functional Flows
- Thermal Performance Trades
  - Key Performance Parameter
  - Technology Selections
  - Thermal Model Development
- Future Work
- References

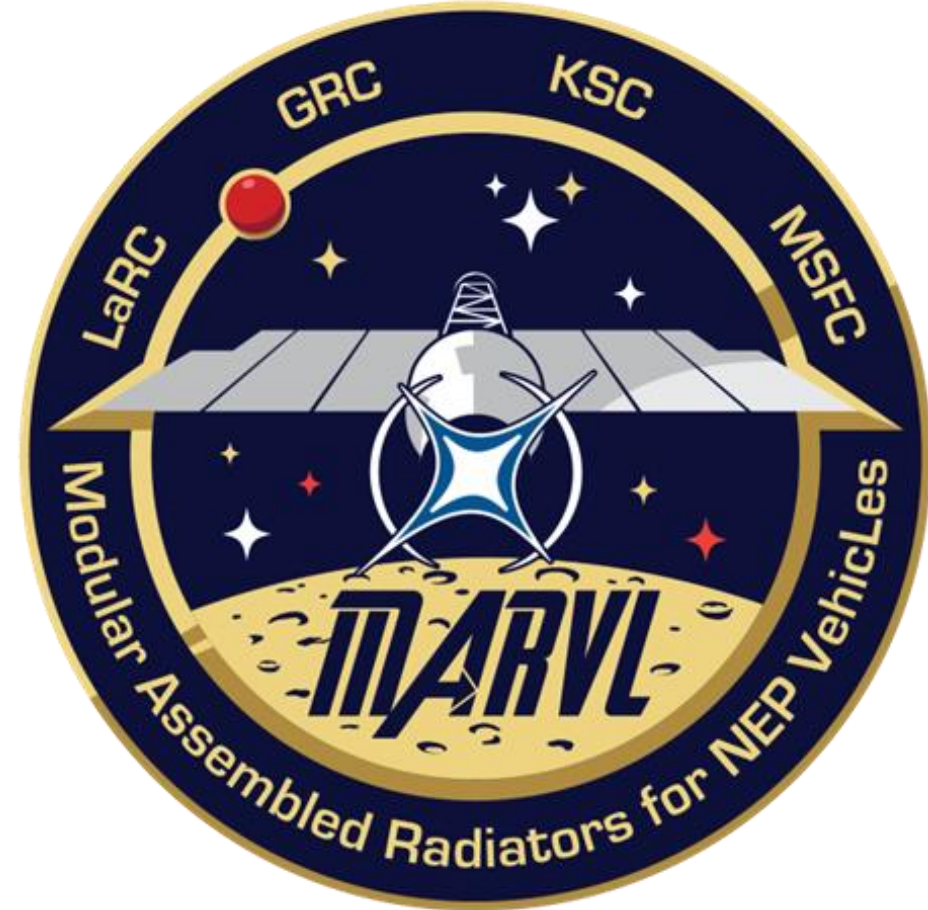



# Hybrid NEP/Chemical Vehicle



- **NASA is challenged to develop nuclear propulsion spacecraft for human-rated and cargo Mars missions in the next decade (late 2030s)**
- Nuclear Electric Propulsion (NEP) has been considered for more than six decades based on fuel efficiencies 10 to 20 times greater than what is currently achievable with conventional propulsion<sup>[1]</sup>
  - Nuclear propulsion vehicles also enable expanded cis-lunar mobility, sustained Mars presence, and deep space exploration
- A Hybrid NEP/Chemical system contains five technology elements<sup>[1,2]</sup>:
  1. Reactor and Coolant Subsystem
  2. Power Conversion Subsystem
  3. Power Management & Distribution Subsystem
  4. Electric Propulsion Subsystem
  5. Primary Heat Rejection Subsystem
- Chemical Stage (LOX-Methane) is not considered a critical technology element, but rather as an engineering development item

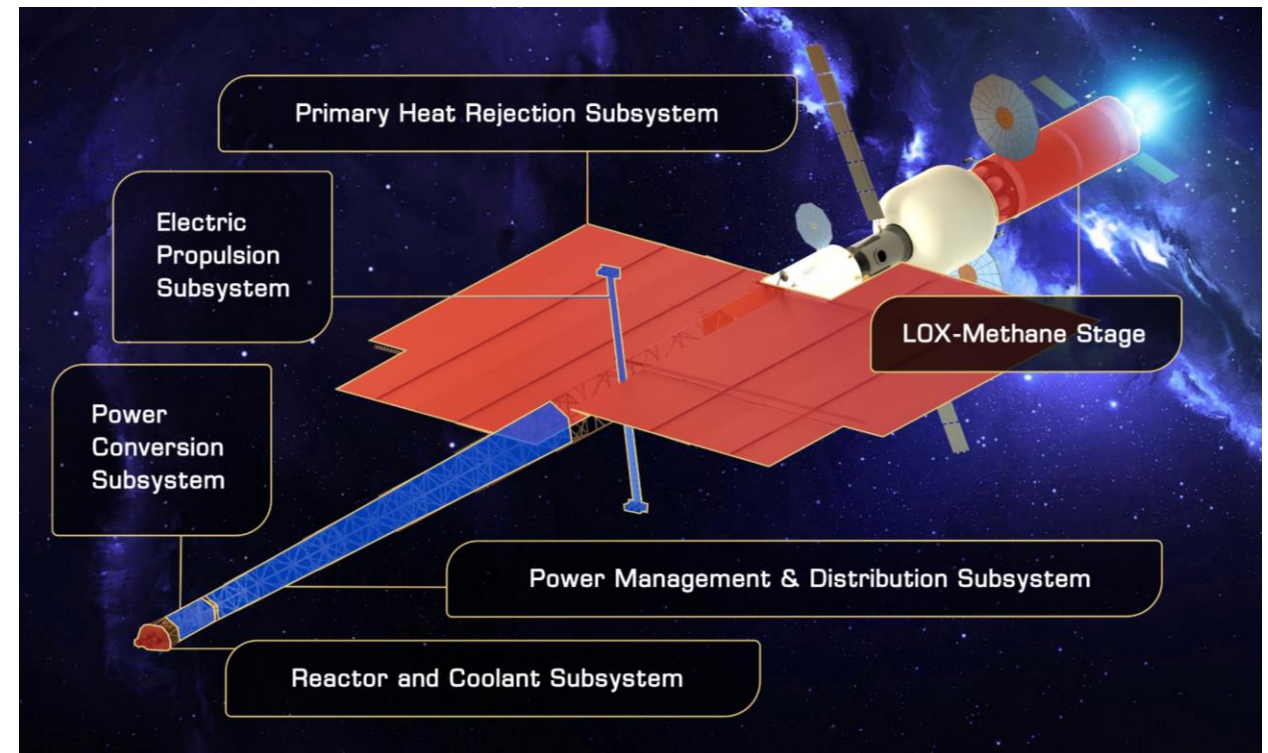

**Note:** The NEP System of Spacecraft shown is an artist's rendition of the crewed version with one EPS propellant stage. The vehicle configuration and number of elements changes throughout the Mars Opposition Class mission. One possible set of subsystem placements is shown and is subject to change.



# Modular Assembled Radiators for NEP Vehicles (MARVL)

Nuclear Electric Propulsion (NEP) contains five key elements; **The Primary Heat Rejection Subsystem (PHRS) is the largest and most massive element** due to the large amount of reactor waste heat:

- Surface area **>3,000 m<sup>2</sup>** and **40-60%** of total NEP dry mass<sup>[1,3]</sup>
- The use of in-Space Assembly (iSA) in designing NEP modular radiators enables the “planar Bi-Wing” configuration and **25% to 65% mass savings**

**Cross-agency team:** LaRC, GRC, KSC, MSFC

## Need, Goal, Objectives (NGO)

<b>Need</b>	Large-scale in-space radiator technology that meets launch vehicle constraints, reduces system mass, improves system performance, reduces risk, and provides future mission planners flexibility in NEP architecture design			
<b>Goal</b>	Design and analyze a lightweight PHRS targeting an NEP capability			
<b>Objective</b>	Define and evaluate a set of PHRS installation and commissioning concepts	Build an integrated simulation to predict and analyze system behavior in relevant environments	Define and analyze a representative modular high-temperature radiator unit design	Define and analyze a high-temperature fluid interface design

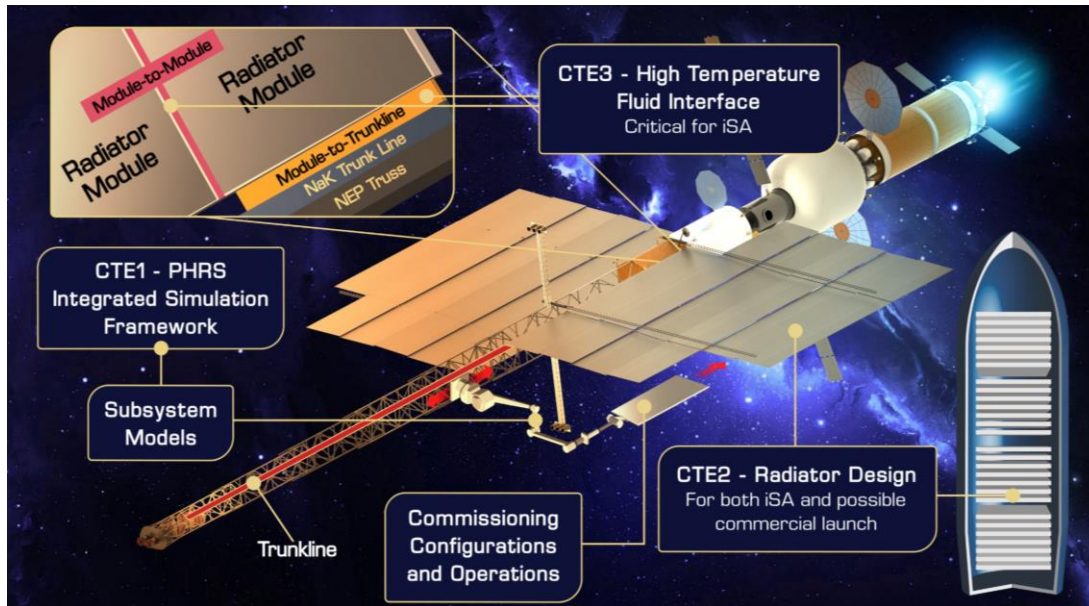

**MARVL Critical Technology Elements (CTE)**

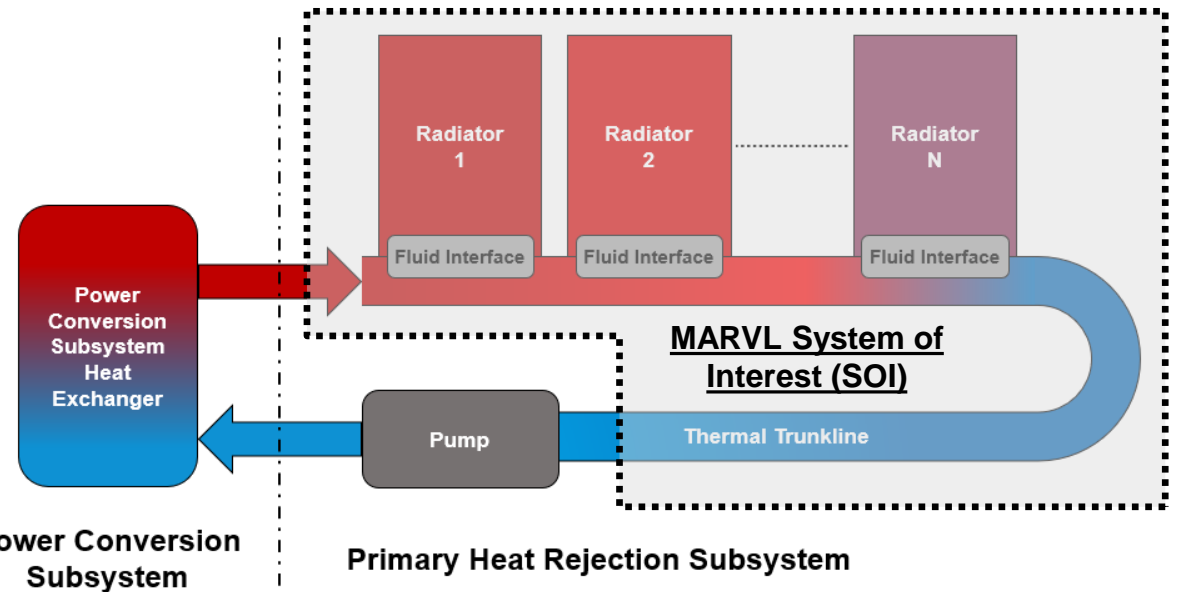



# State of the Art Comparison - ISS Radiators



- The International Space Station (ISS) Active Thermal Control System (ATCS) radiator arrays, with their Orbital Replacement Unit (ORU) interfaces, are the most relevant state of the art in terms of size and commissioning approach
  - ISS radiator arrays were launched in several segments, robotically assembled on orbit, then remotely deployed
  - However, ISS radiators do not meet NEP PHRS requirements*

## System Characteristics: ISS Radiators vs MARVL PHRS

System/ Characteristic	ISS Radiator Arrays	MARVL PHRS
Commissioning Method	Robotically Installed & Deployed [5]	Robotically Installed & Deployed or Fully Assembled
Surface Area	~1300 m <sup>2</sup> [5]	>3000 m <sup>2</sup> [1]
Launch Vehicle(s)	~5 Space Shuttles [5]	TBD
Thermal Working Fluid	Anhydrous Ammonia [5]	Liquid Metal NaK [1]
Fluid Temp.	~270 K to 290 K [6]	~330 K to 550 K [1,4]
Effective Radiation Temp.	~285 K [6]	~400 K [3]
Areal Density	~7.0 kg/m <sup>2</sup> [7]	<4.5 kg/m <sup>2</sup> [1,4]
Heat Rejection	~125 kWth [5]	~4 MWth [1,4]
Design Environment(s)	LEO ~400 km altitude ISS Interfaces	Mars Opposition Class Mission NEP/Chem Vehicle Interfaces





# State of the Art Comparison - ISS Radiators



**EATCS Stowed in Space Shuttle**

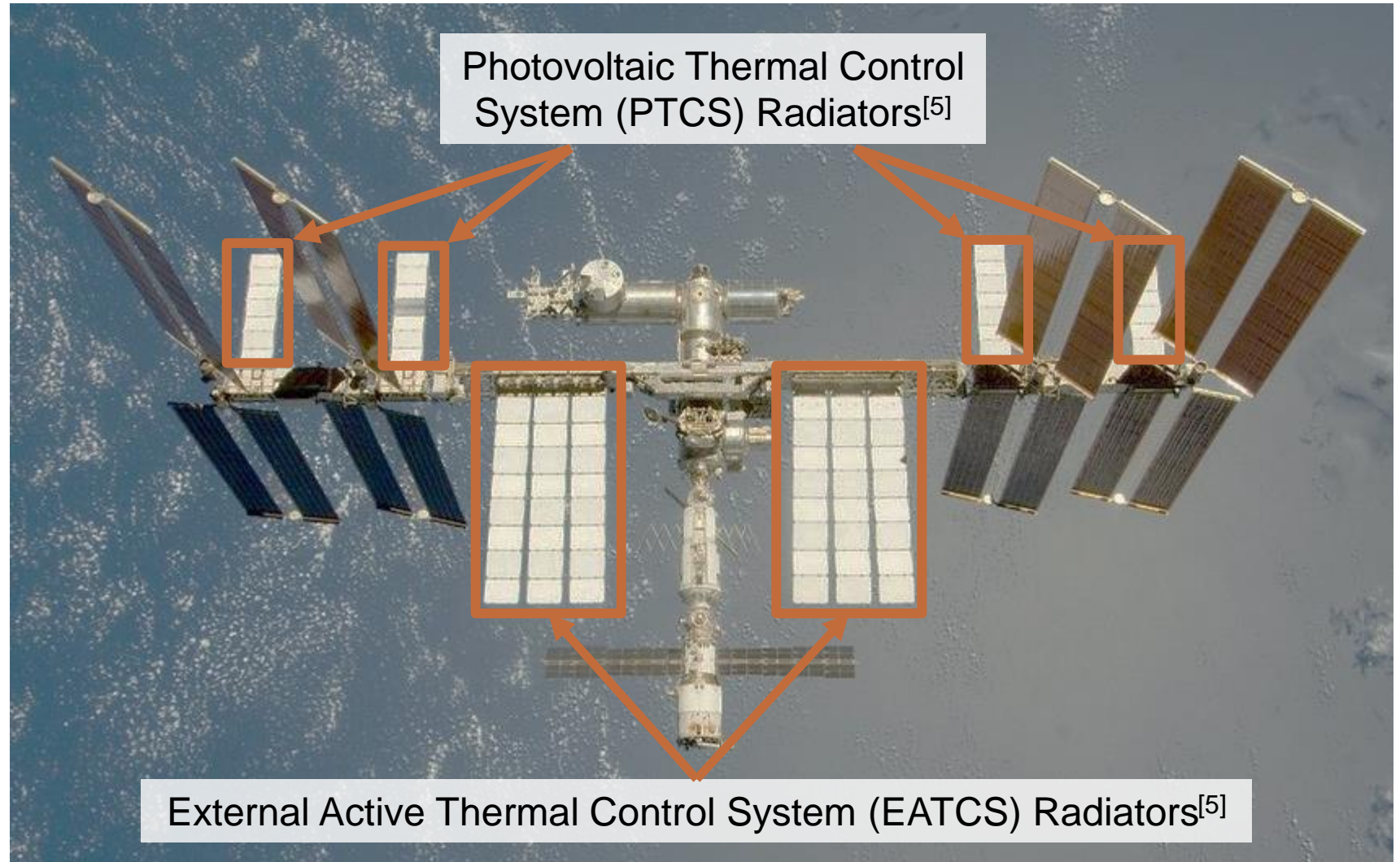

**ISS Radiators Deployed In-Orbit**



# Target Application - Enveloping Mars Mission

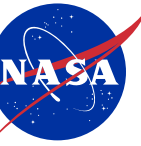

- Crewed mars missions involve many mission phases and locations each with differing environments
- The target application for technology development is a Crewed NEP Mars Opposition Class Mission<sup>[1]</sup>:
  - Crew departure date: 2039
  - Total mission duration: ~3 years
- **System integration and loads:** with hybrid NEP/chemical vehicle (NEP for cruise phases & chemical stage to enter/exit gravity wells)
- **Possible locations:** Low Earth Orbit (LEO), Near Rectilinear Halo Orbit (NRHO), Lunar Distant High Earth Orbit (LDHEO), Interplanetary, Mars Orbit, Venus Flyby
- **Relevant environments:** thermal, vacuum, Micro Meteoroid and Orbital Debris (MMOD), radiation, launch loads, in-space loads, microgravity

## Opposition Class Mars Mission<sup>[8]</sup>

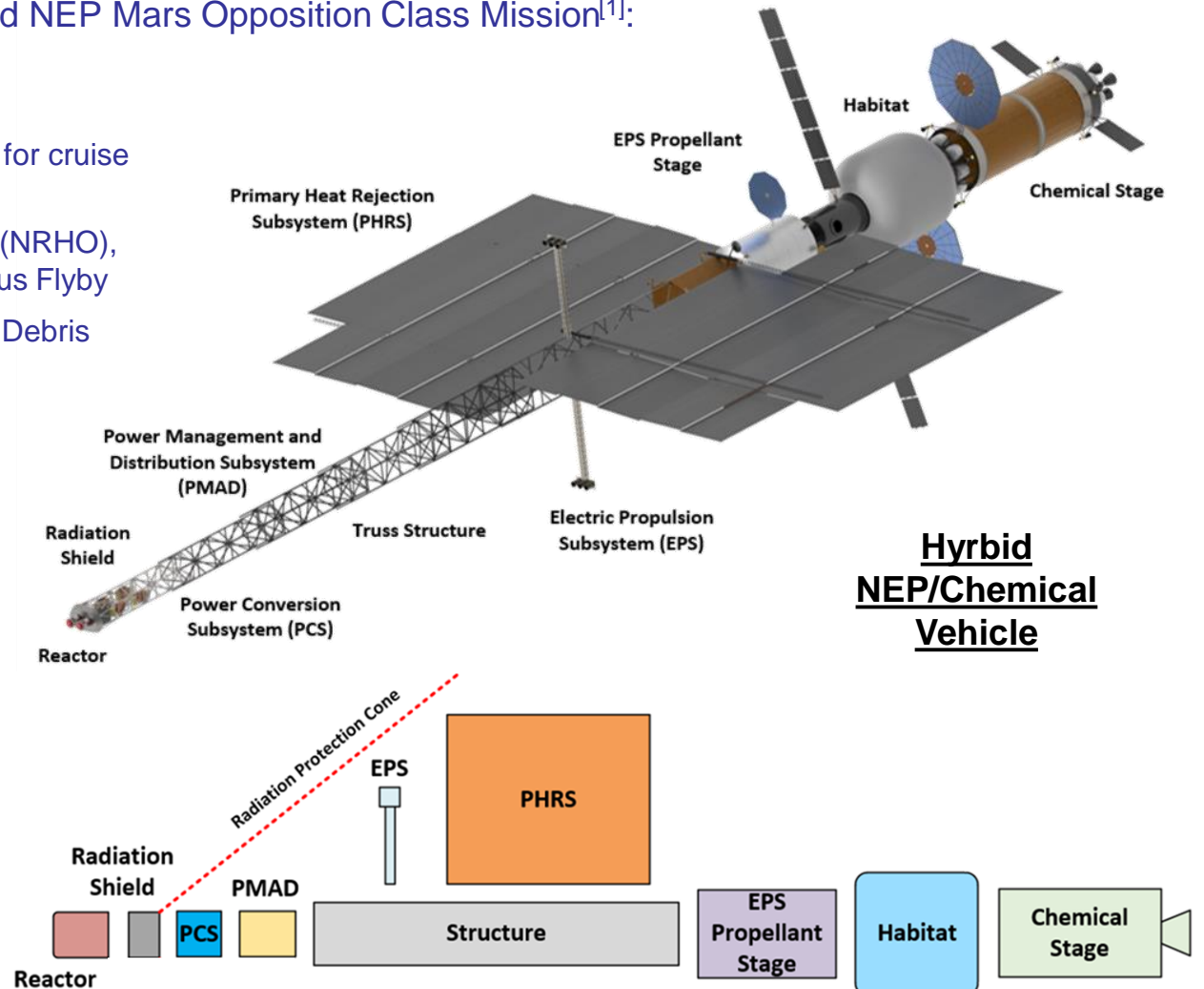
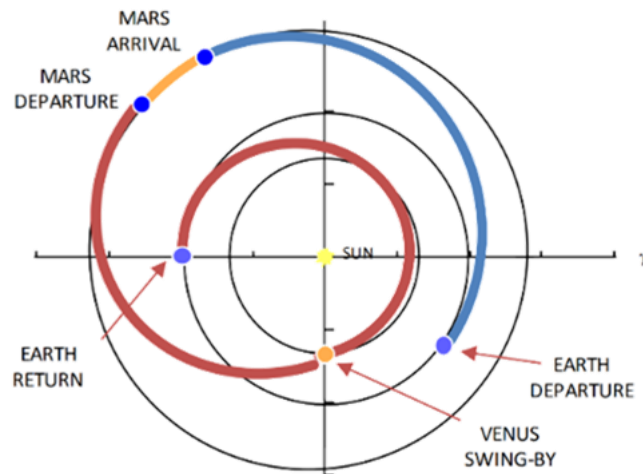

## Hybrid NEP/Chemical Vehicle

**Note:** The NEP System of Spacecraft shown is an artist's rendition of the crewed version with one EPS propellant stage. The vehicle configuration and number of elements changes throughout the Mars Opposition Class mission. One possible set of subsystem placements is shown and is subject to change.



# Enveloping Mission - Thermal Environment Modeling



- Developed reduced order models in ANSYS Thermal Desktop (TD) to define orbital cases and investigate PHRS heat rejection capability relative to sink temperature vs orbit period
  - Results inform operations (pointing and orientation requirements), thermal constraints, orbit selections, sensitivities to adjacent vehicle elements, and radiator optical property sensitivities
  - "Thermal Considerations for 2039 Opposition Class Nuclear Electric Propulsion/Chemical Propulsion Crewed Mars Mission" presentation/paper by Tai Valdés includes details on orbit definitions, environmental parameters, and plate model results<sup>[9]</sup>

## TD Representative Full Vehicle Model

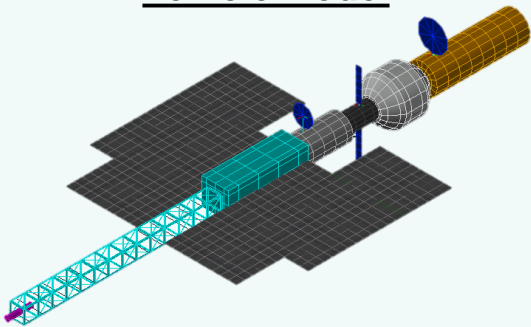

NEP Element	Temp. [K]	$\alpha_s$	$\epsilon_{IR}$
Reactor	550	1	1
Truss	300	0.92	0.8
NEP Base	300	0.19	0.89
EPS Interstage			
Habitat & Dock			
Chemical Stage			
Solar Arrays	340	0.89	0.85
PHRS Radiators	400	0.85	0.3

## TD Orbital Environments<sup>[9]</sup>

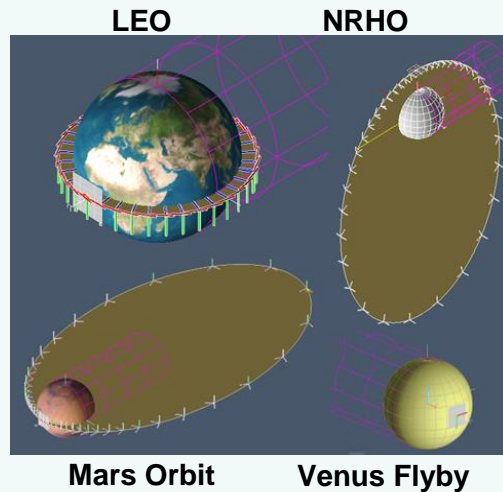

## TD Plate Model<sup>[9]</sup>

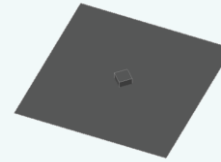

## Thermal Radiation Exchange

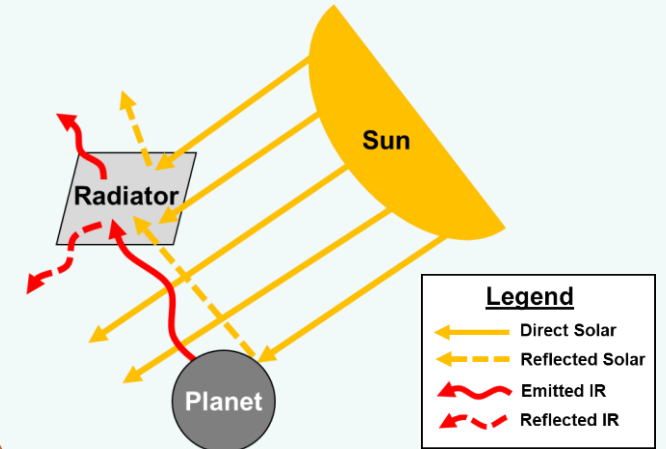

## Sink Temp. & Heat Rejection Capability Calculations<sup>[10-14]</sup>

$$T_{sink} = \left( \frac{1}{\sigma} \left( \frac{\alpha_{srad}}{\epsilon_{IRrad}} Q_{sinc} + Q_{IRinc} \right) \right)^{0.25}$$

$$Heat\ Rejection\ Capability\ [\%] = \left( \frac{A_{rad} \sigma \epsilon_{IRrad}}{A_{rad} \sigma \epsilon_{IRrad}} \right) \left( \frac{(\eta T_{rad}^4 - T_{sink}^4)}{(\eta T_{rad}^4)} \right) * 100$$

Parameter	Symbol	Unit
Radiator Solar Absorptivity	$\alpha_{srad}$	N/A
Radiator Area	$A_{rad}$	m <sup>2</sup>
Radiative Efficiency	$\eta$	N/A
Effective Radiator Temp.	$T_{rad}$	K
Incident Solar Flux	$Q_{sinc}$	W/m <sup>2</sup>
Radiator IR Emissivity	$\epsilon_{IRrad}$	N/A
Incident IR Flux	$Q_{IRinc}$	W/m <sup>2</sup>
Sink Temp.	$T_{sink}$	K
Stefan-Boltzmann Constant	$\sigma$	W/m <sup>2</sup> K <sup>4</sup>



# Reduced Order Full Vehicle Model - Key Findings



- Radiator edge to Sun orientation is the most ideal in all mission locations when the reactor and PCS are online
  - Face to Sun orientation is ideal when radiators are exposed to space prior to reactor/PCS startup
- Regardless of orientation (R2VV or R2P), heat rejection capability predictions are within 8% relative to the plate model for all analyzed orbits
- Radiator wings experience elevated sink temperatures near adjacent spacecraft elements

## TD, View Factor to Space

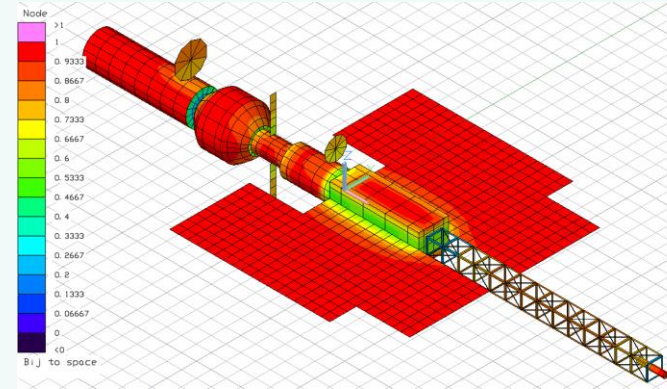

## Example Orbits: Heat Rejection Capability vs Time

— Plate Model      — Full Model  
— Full Model R2VV    — Full Model R2P

### LEO 500km (Edge to Sun, Horizontal), Cold, Beta = 0°

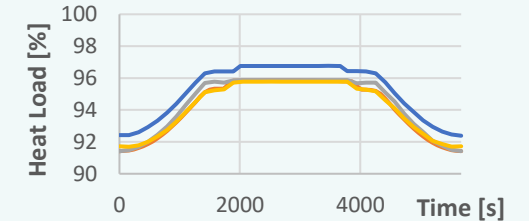

### LEO 500km (Edge to Sun, Horizontal), Hot, Beta = 52°

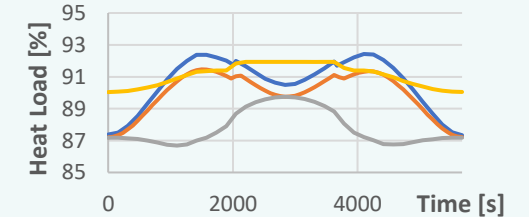

### Mars 1-Sol (Edge to Sun, Horizontal), Hot, Beta = 90°

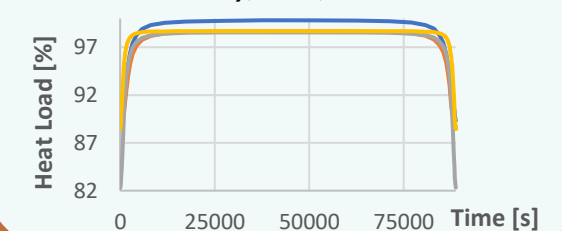

## TD Full Vehicle Model: Orientation Examples

Edge to Sun (Plate Model Orientation)

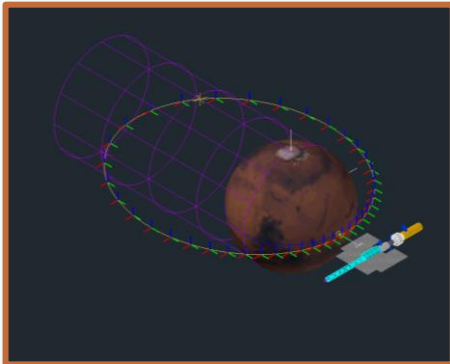

Edge to Sun & Reactor to Velocity Vector (R2VV)

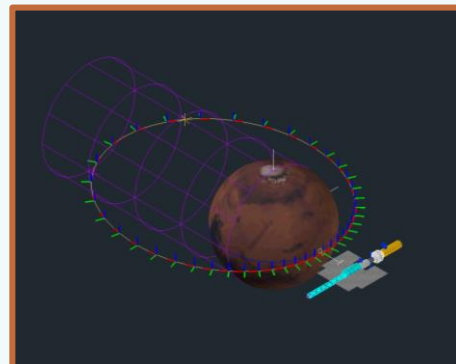

Edge to Sun & Reactor to Planet (R2P)

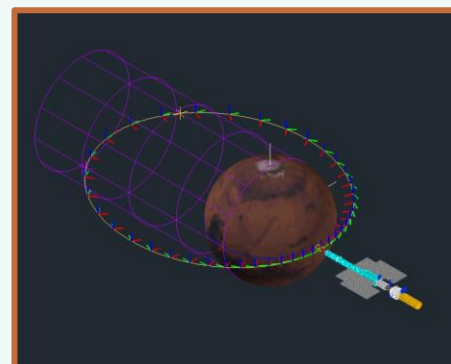



# System of Interest (SOI) - External Interfaces

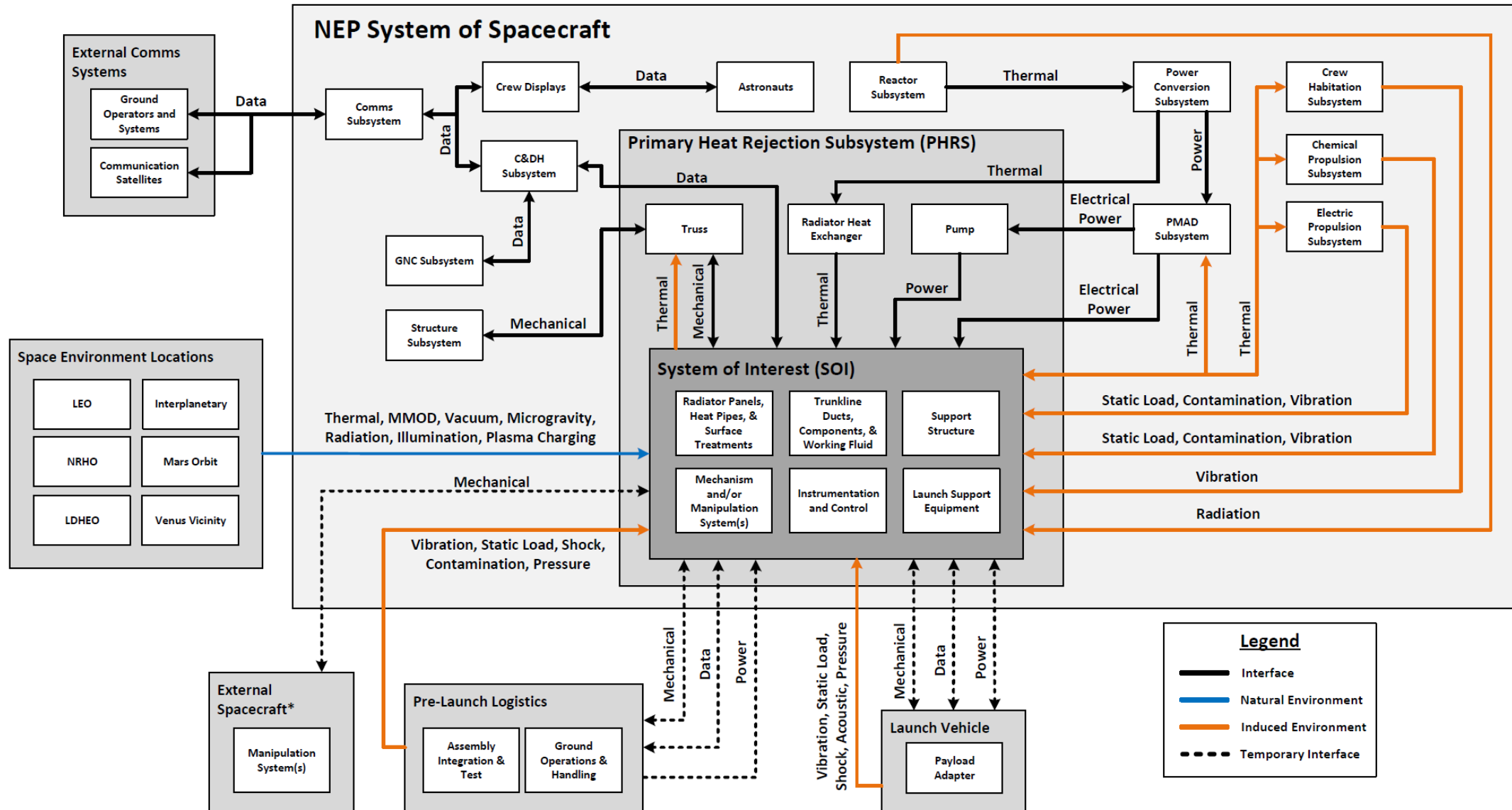

\*External spacecraft may be used to install the radiator wings, but a decision is pending. This element may be removed depending on trade study results.



# NEP Power System



## Primary Heat Rejection Subsystem

## Power Conversion Subsystem & Reactor

## Power Management and Distribution Subsystem & Electric Propulsion

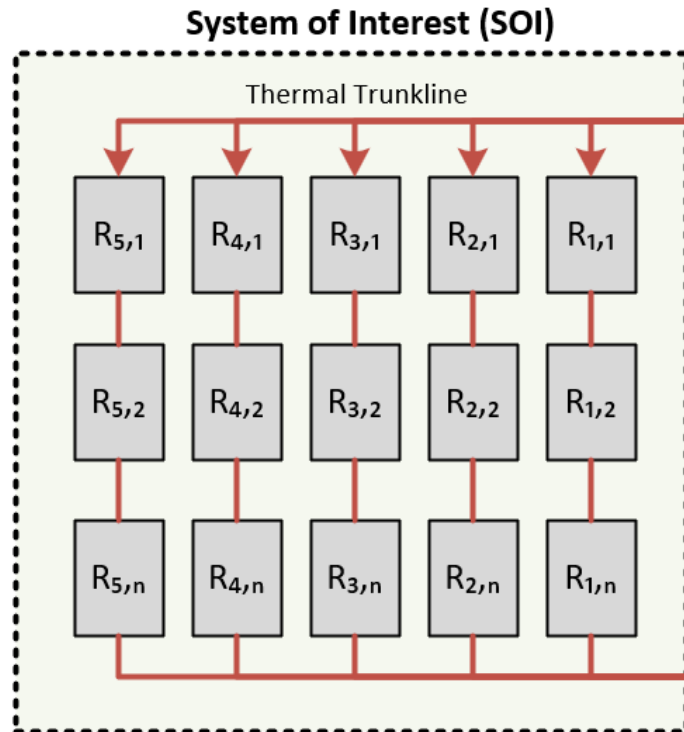

RIC

ROC

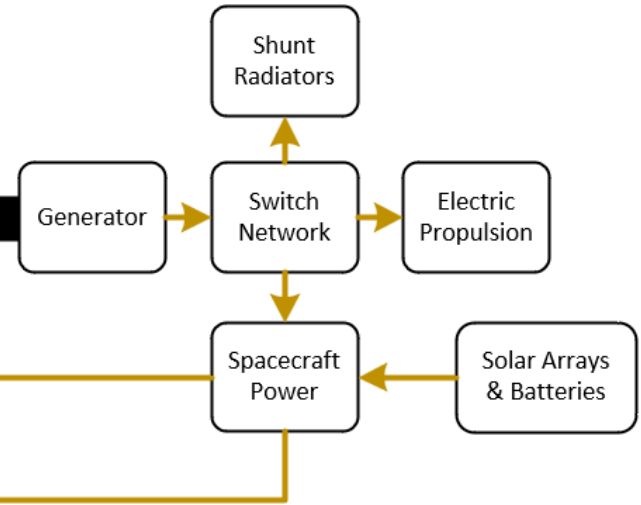
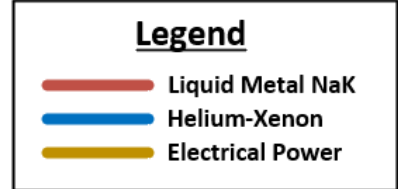
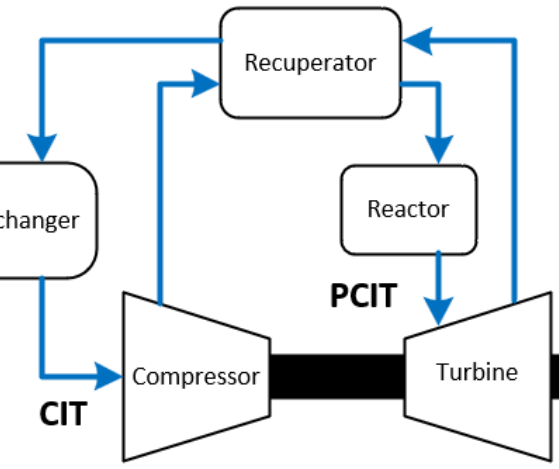
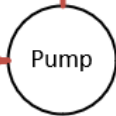
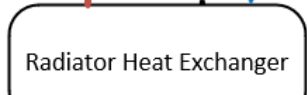

Liquid metal NaK line shown includes components such as valves, accumulators, and interfaces

$R_{n,m}$  = Radiator fluid loop number, panel number

RIC = Radiator Inlet Condition, ROC = Radiator Outlet Condition

ROC = CIT

CIT = Compressor Inlet Temp, PCIT = Power Conversion Inlet Temp



# Installation and Commissioning Concepts

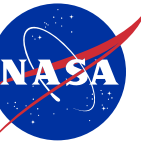

## Definitions:

- **Installation:** incremental assembly/deployment of the PHRS radiators prior to reactor startup
- **Commissioning:** achievement of an operational PHRS in-line with reactor startup

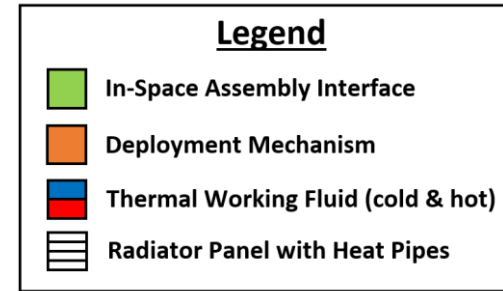

## Full Deployment

- Single-launch, co-manifested with the rest of the NEP power system
- Constrained from a launch vehicle mass capability to orbit standpoint
- Limited subsystem design flexibility and extensibility

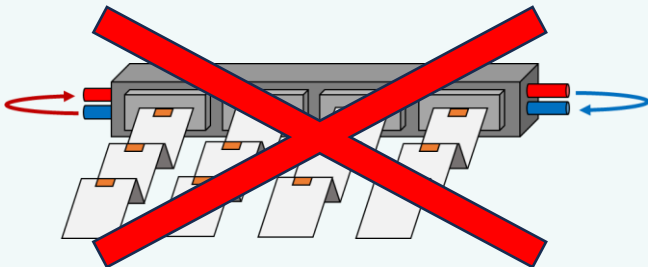

## Hybrid

- Robotically assembled/installed units which are then deployed
- Exploring hard mounted and mobile robotic agents
- Requires multiple launches
- Enables architectural flexibility and extensibility

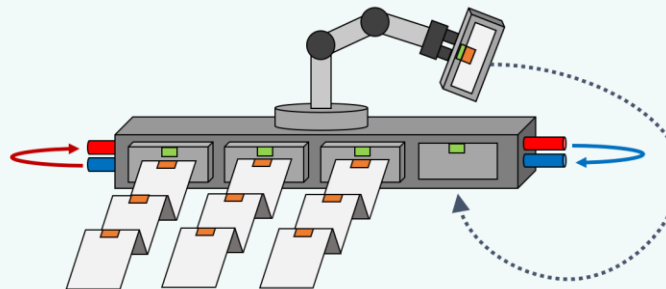

## Full Assembly

- Radiator units are robotically assembled into configuration
- Exploring hard mounted and mobile robotic agents
- Requires multiple launches
- Enables architectural flexibility and extensibility

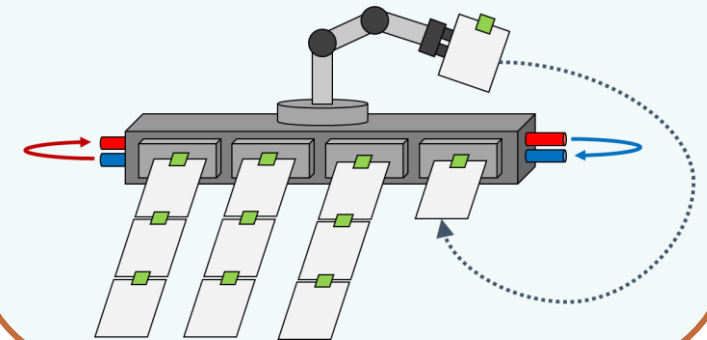

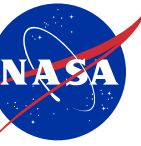

# Radiator Unit Options

**Radiator Unit:** a modularized collection of radiative heat rejection surfaces to include structural supports, fluid loop(s) to each panel or module, surface treatments, heat pipes, and panel sheet materials

- Pending trade studies, a radiator unit may be a panel, a module, array, or wing

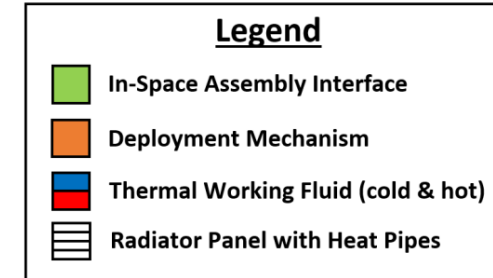

## Radiator Unit Terminology

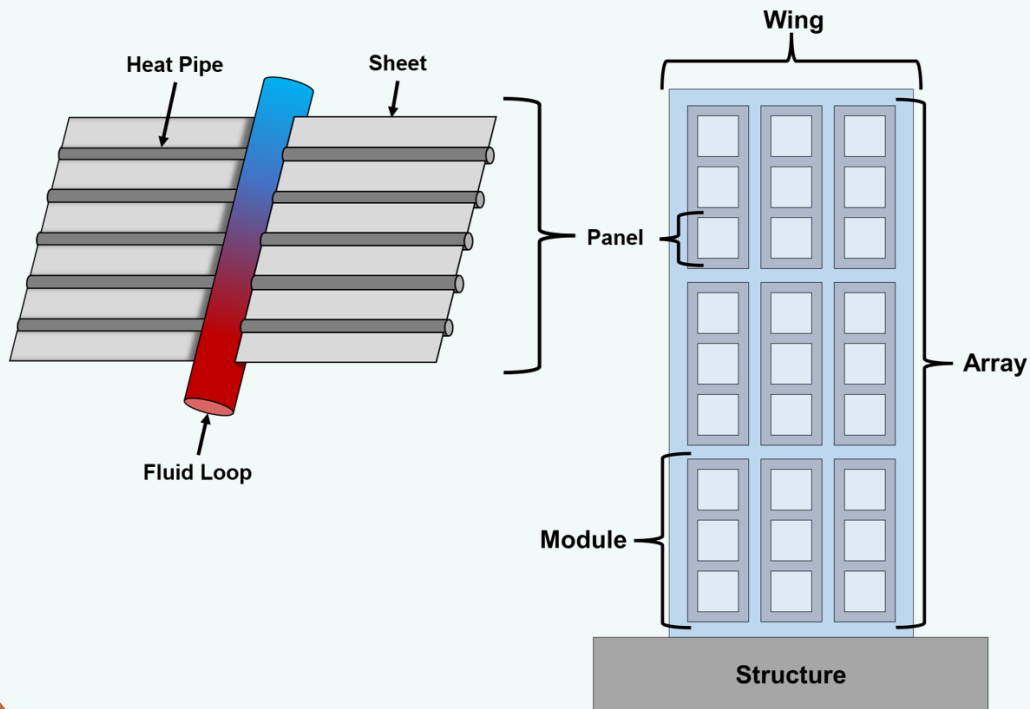

## In-Space Assembled Unit Options

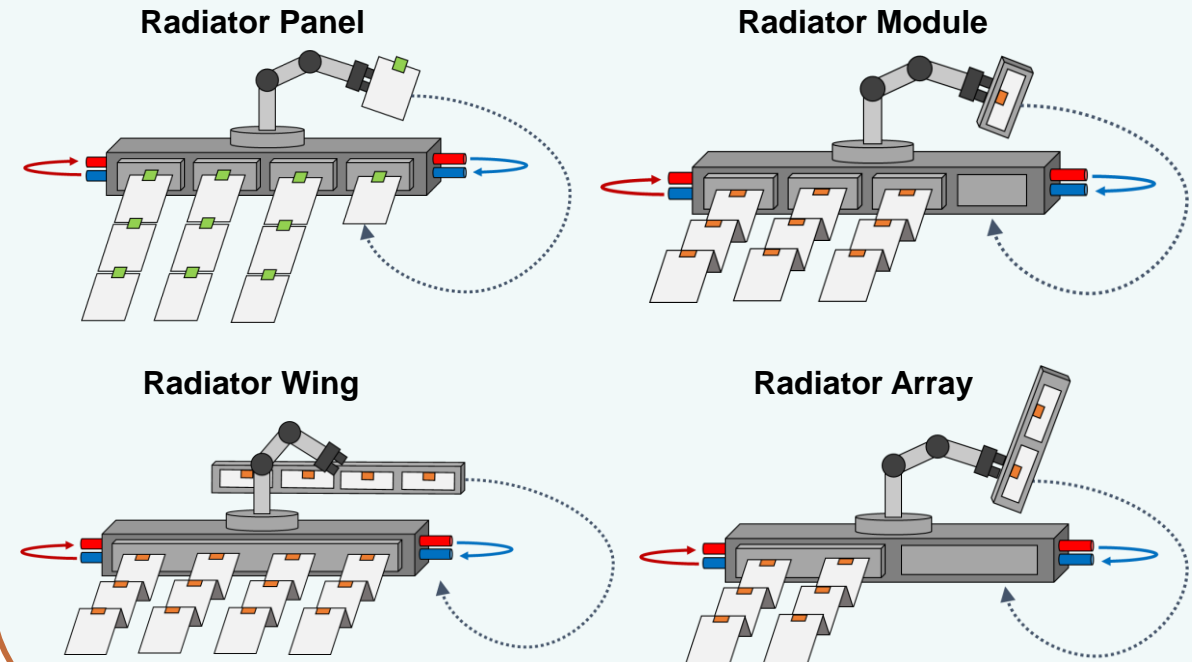



# Hybrid Concept - SOI Internal Interfaces

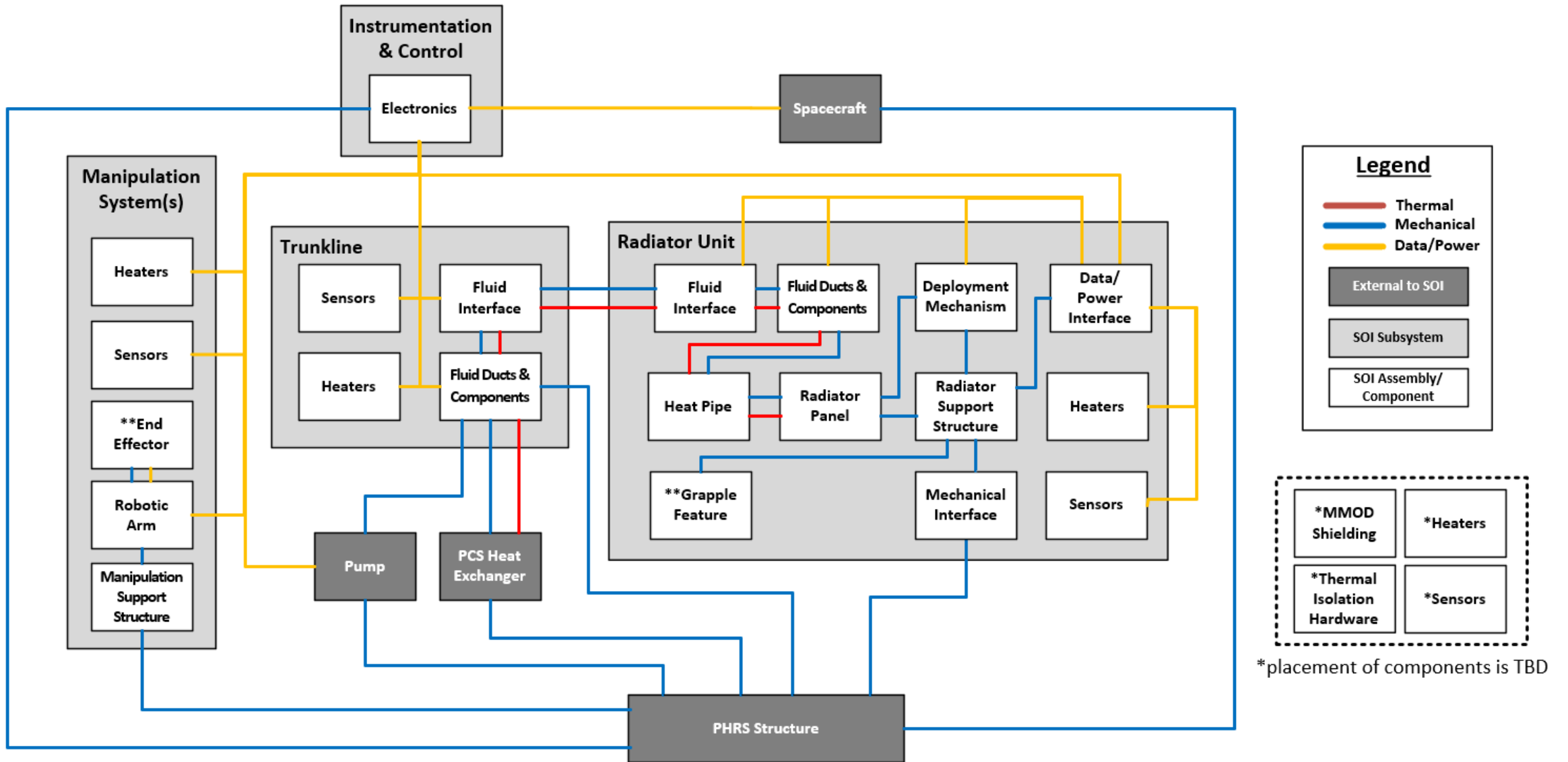

\*\*End effector to grapple feature mechanical connection is temporary



# Full Assembly Concept - SOI Internal Interfaces

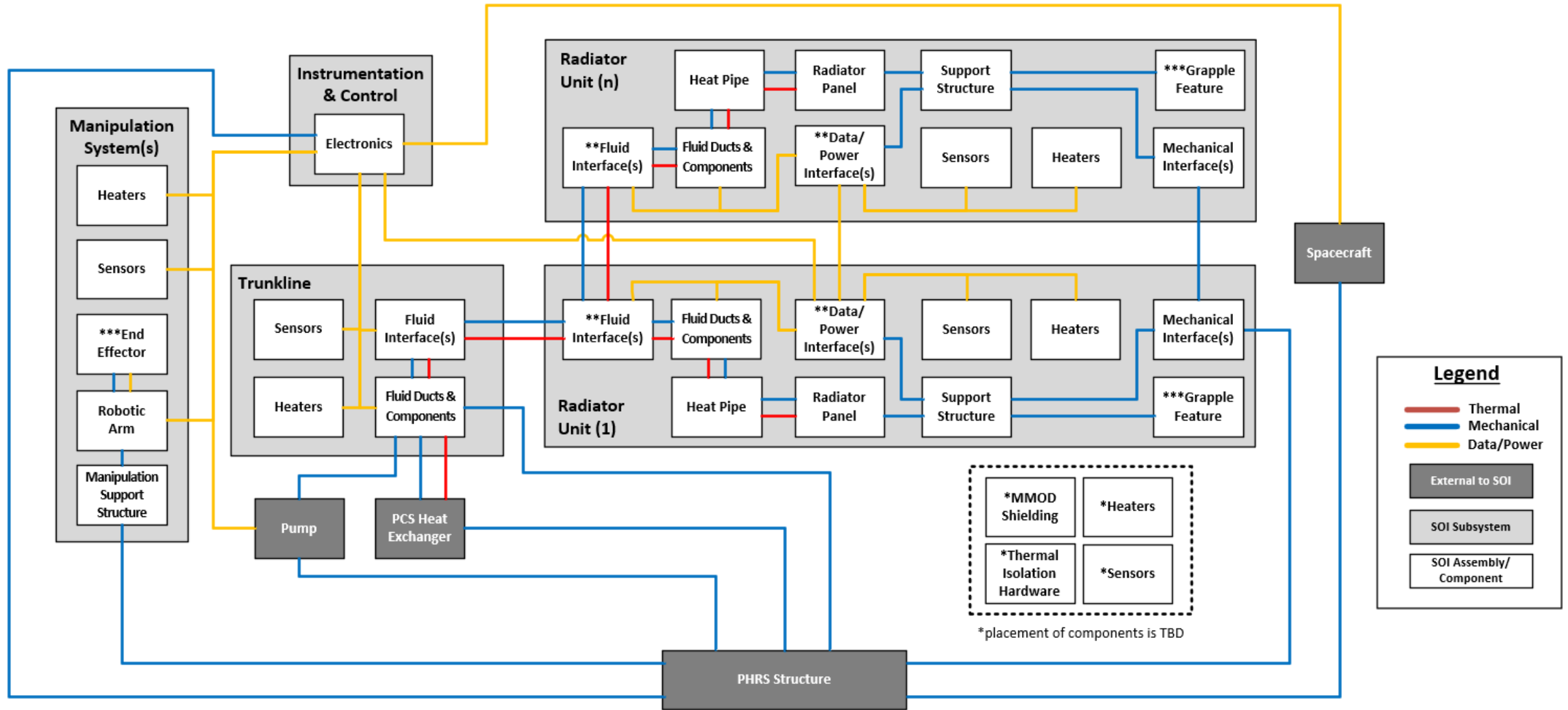

\*\*Parallel vs series fluid and data/power interface from Radiator Unit to Radiator Unit is TBD

\*\*\*End effector to grapple feature mechanical connection is temporary



# Initial Functional Flow Diagram

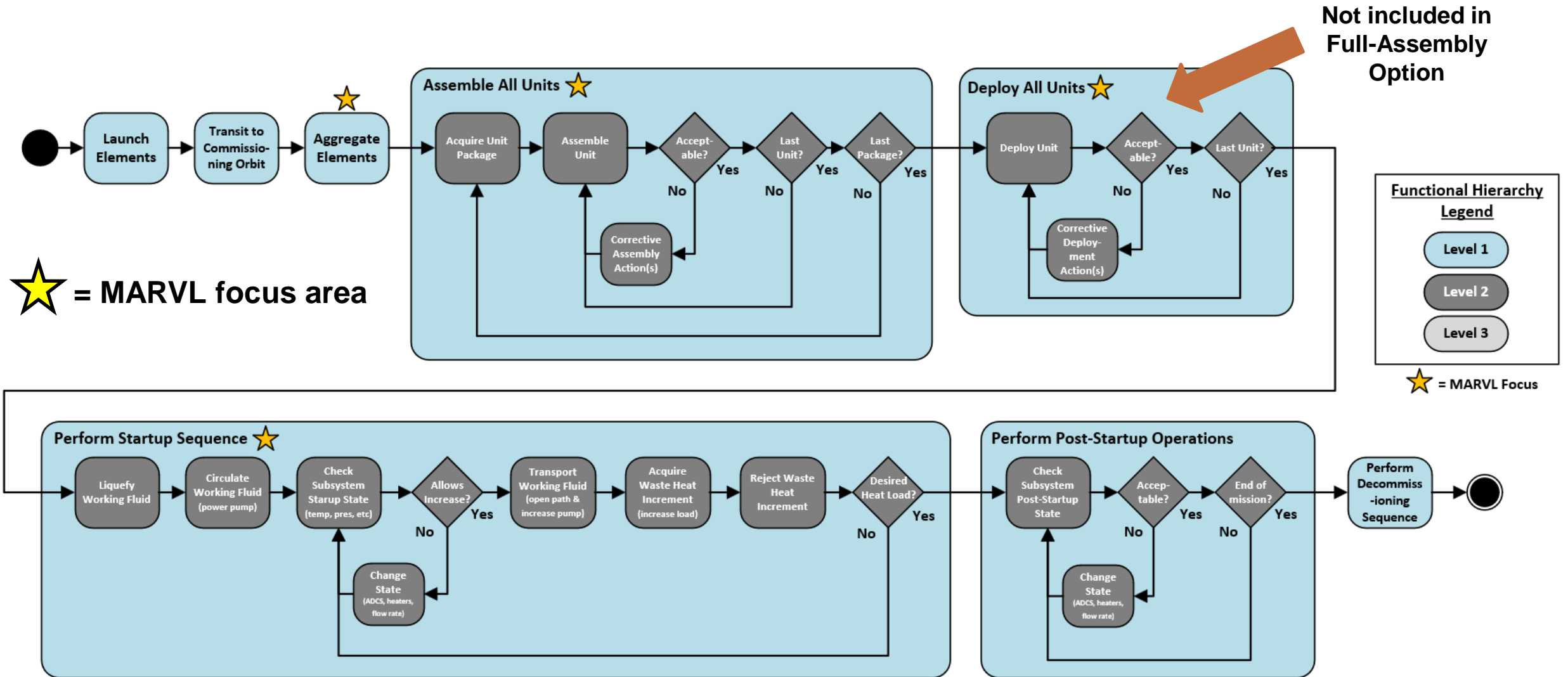
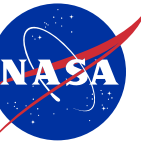



# MARVL Key Performance Parameter (KPP)



- Specific mass per unit power produced by the reactor (kg/kWe) is a measure of NEP architecture feasibility
  - 13 to 24 kg/kWe for the nuclear power system (includes the 5 NEP technical elements) represents mission closure
- MARVL's Key Performance Parameter (KPP) is defined at the PHRS level; the radiators cannot be designed independent of the PCS
  - Minimizing overall NEP specific mass is a complex non-linear relationship between radiator area, power conversion efficiency, working fluid temperatures, heat pipe operating limits, and technology readiness (with respect to environments and system integration)
- Increasing radiator operating temperature does not result in overall system mass improvement
  - Reduces surface area at the cost of decreasing PCS cycle efficiency, thus requiring more heat to be rejected
  - Requires high temperature ( $\geq 1400$  K) reactor and turbine
  - Requires developing new heat pipe technologies (next slide)

## MARVL Key Performance Parameter (KPP)

Title	Description	Unit	SoA	Threshold	Goal
PHRS specific mass ( $\alpha$ )	PHRS mass per unit electrical power produced by nuclear reactor	kg/kWe	$\sim 11^*$	$8^\dagger$	$3.5^\ddagger$

\*ISS Radiators (used as panel analogy only – deployment and trunkline similar to published NEP concepts) at  $2500\text{m}^2$  for  $2\text{MWe}$  NEP;  $^\dagger$  25%  $\alpha$  reduction;  $^\ddagger$  65%  $\alpha$  reduction; SoA with deployment mechanisms at an areal density of  $3.5\text{ kg/m}^2$  is  $16\text{ kg/kWe}$

The main lever to achieve improved overall system mass from a radiator design perspective is decreasing areal density ( $\text{kg/m}^2$ )

## PCS Inlet and Outlet Temperatures vs Radiator Area (left) and Power System Specific Mass (right)

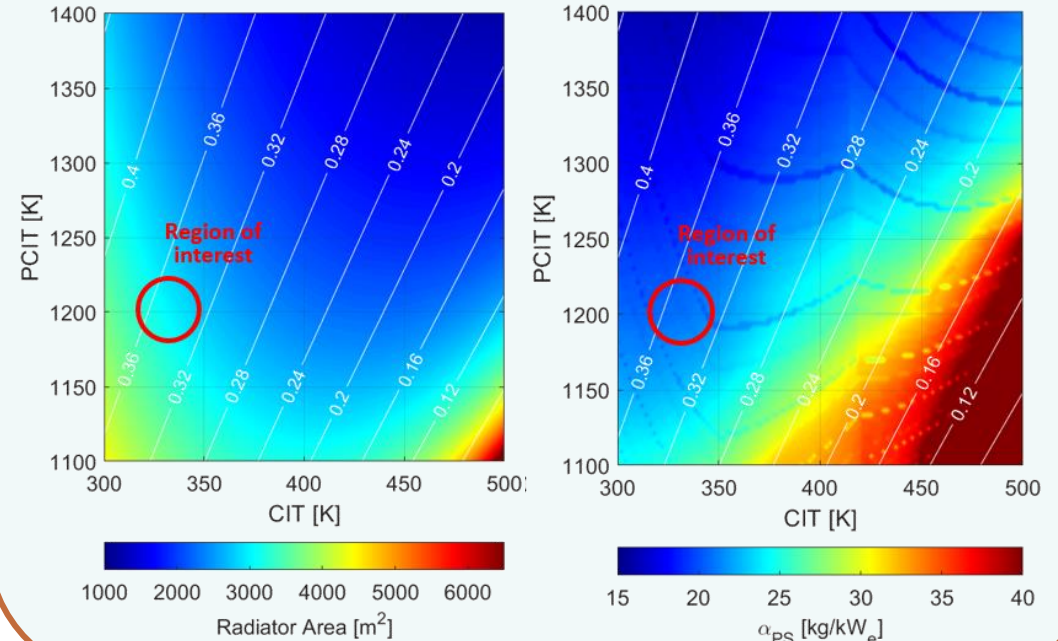

**Note:** Plots were obtained via the AMA NEP-SIM model<sup>[4]</sup>, Plots assume  $2\text{ MW}_e$  NEP producing  $4\text{ MW}_{th}$ , the white lines in displayed plots represent PCS efficiency, CIT: Compressor Inlet Temperature, PCIT: Power Conversation Inlet Temperature



# Thermal Trunkline Routing and Heat Pipe Options

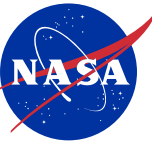

Maximum Radiator Inlet Temperature (RIT) is limited by heat pipe technology

- Water heat pipes operate at  $\leq 550$  K; high Technology Readiness Level (TRL)
- Low TRL heat pipes required for higher temperatures
  - Cesium heat pipes for  $>650$  K; low TRL
  - Intermediate temperature heat pipes for 550 K to 650 K; very low TRL and compatibility concerns

Working fluid re-circulation can be used to increase RIT without higher temperature heat pipes, but with drawbacks:

- Increased fluid mass flow rate which decreases fluid residence time (less efficient heat transfer)
- Additional fluid duct and associated component masses

Another option is radiator embedded pumped fluid loops (~5% mass improvement over water-based heat pipes)

- MMOD shielding mass required to mitigate risk of external fluid leakage over  $\sim 3000$  m<sup>2</sup> of radiator area obviates any mass improvements

**Limited Inlet Temperature<sup>[3]</sup>**

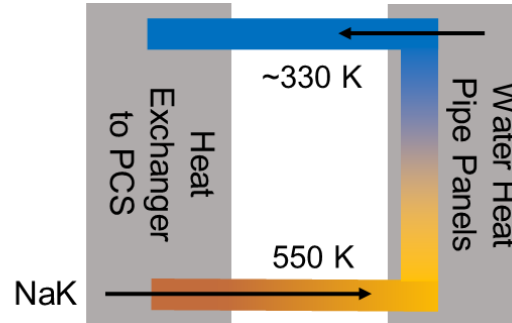

**Re-Circulation<sup>[3]</sup>**

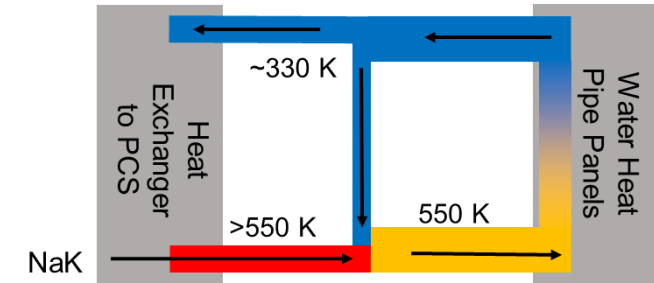

**Cesium Heat Pipes, Re-Circulation**

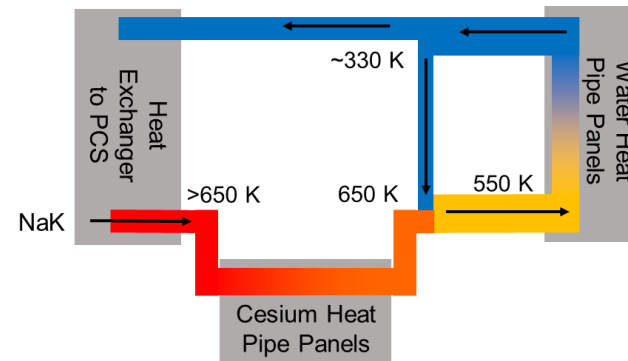

**Pumped NaK Loops<sup>[3]</sup>**

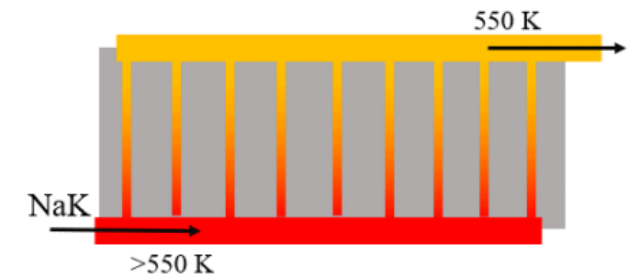



# Technology and State Property Selection



- Limiting the radiator inlet temperature to  $\leq 550$  K was selected as it minimizes overall NEP system mass and avoids concerns with low TRL heat pipe technology
- For an NEP power system producing  $\sim 2$  MWe (four 500 kWe units) and  $\sim 4$  MWth total:
  - PCIT of 1200 K due to temperature limits concerns for high TRL PCS turbine materials
    - Can be increased to 1400 K while still employing water-based heat pipes
  - Minimum overall system mass occurs at CIT of  $\sim 330$  K
  - Maximum titanium-water heat pipe temperature is 550 K
  - Maximum working fluid pressure is  $\sim 500$  kPa
  - Effective average radiator temperature is 400 K
  - PCS efficiency of  $\sim 34\%$
  - Radiator area of  $\sim 3000$  m<sup>2</sup>

**Limited Inlet Temperature<sup>[3]</sup>**

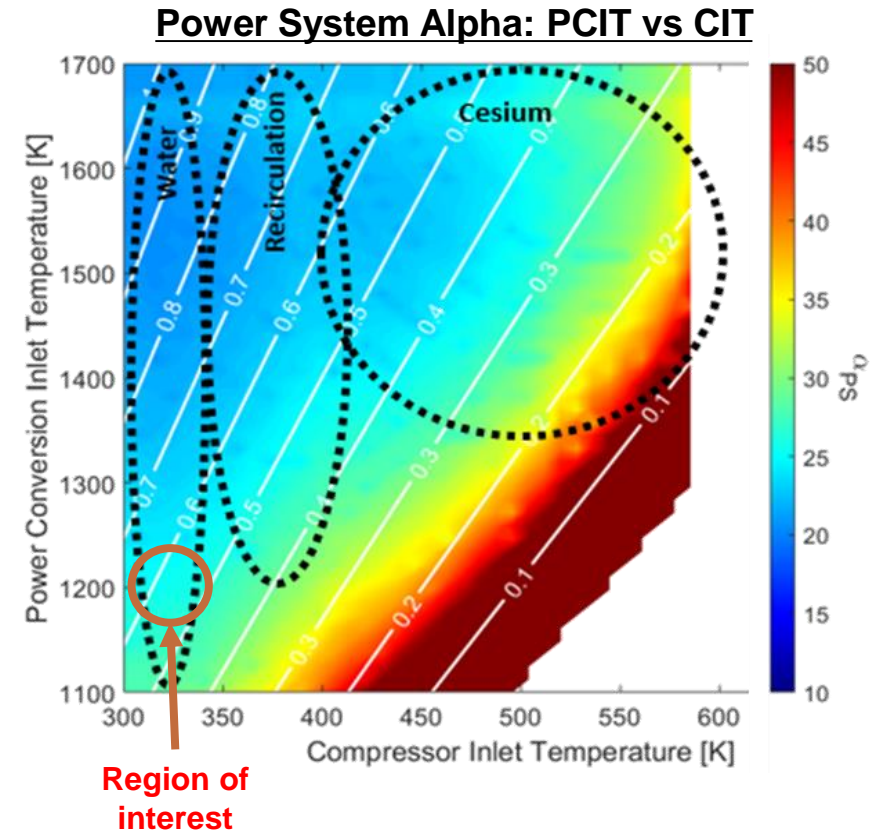
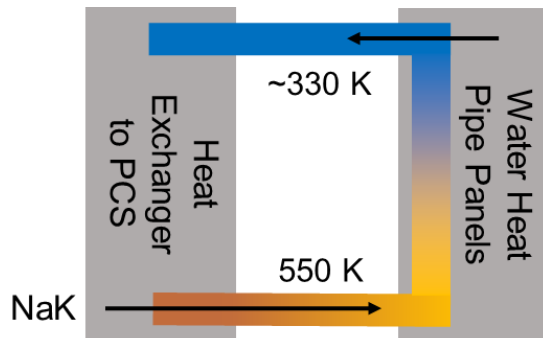

**Note:** Plots were obtained via the AMA NEP-SIM model<sup>[4]</sup>, the white lines in displayed plots represent PCS efficiency, efficiency lines on slide 18 are more accurate than those displayed on this slide



# Pumped Thermal Working Fluid Selection



- Systems analysis models were used to predict PHRS specific mass for three working fluid candidates (NaK, Water, and Galinstan)
- Galinstan has a wider liquid operating temperature range than NaK, but performs very poorly due to its low specific heat capacity
- Water results in lower specific mass than NaK by  $\sim 1 \text{ kg/kW}_e$ , but with other concerns:
  - Requires high pressure  $\sim 7 \text{ MPa}$  to remain liquid
  - Positive coefficient of thermal expansion when freezing is a major concern for closed cycle fluid loops
- NaK was selected as the working fluid due to its low  $\text{kg/kW}_e$ , reasonable liquid operating temperature range, and radiation compatibility

**Working Fluid Properties**

Parameter	NaK	Water	Galinstan
Density ( $\text{kg/m}^3$ )	$\sim 900$	$\sim 1000$	$\sim 6000$
Specific Heat ( $\text{J/kg}\cdot\text{K}$ )	$\sim 1000$	$\sim 4000$	$\sim 300$
Viscosity ( $\text{kg/m}\cdot\text{s}$ )	$\sim 7 \times 10^{-4}$	$\sim 9 \times 10^{-4}$	$\sim 2 \times 10^{-3}$

**Working Fluid vs Overall PHRS Specific Mass**

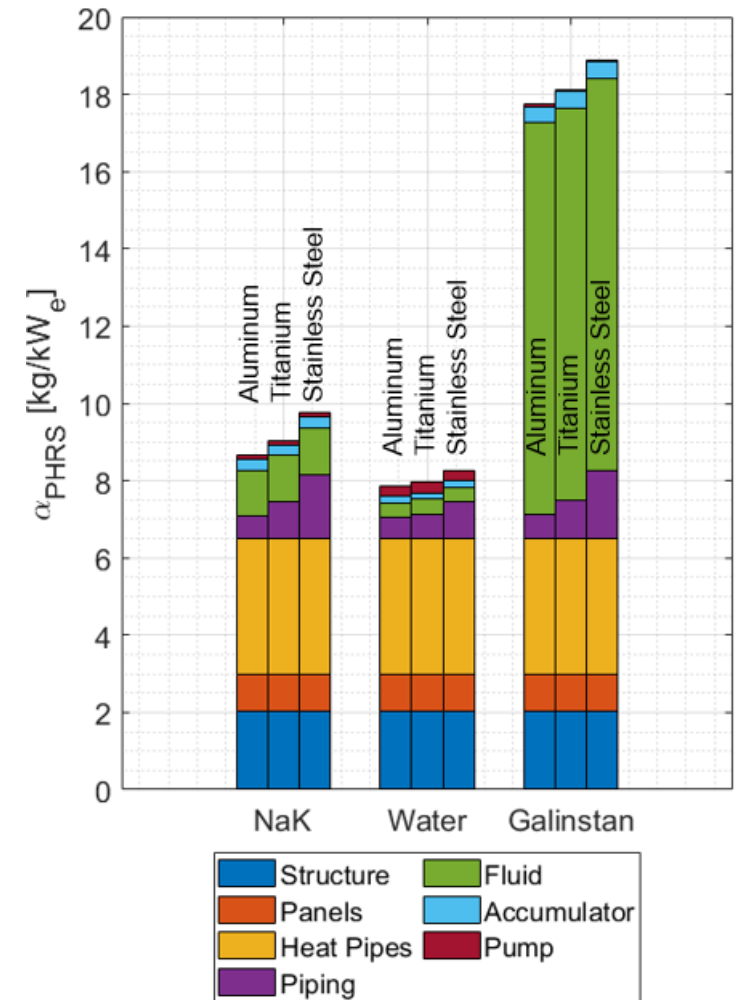

Note: Plot was generated via the AMA NEP-SIM model<sup>[4]</sup>



# Solar Pitch & Radiator Deployment Angle Sensitivities



- Heat rejection capability for a constant radiator area with varying solar flux and solar pitch & deployment angles
  - Absorbed solar flux obtained from thermal desktop, neglecting albedo and planetary IR
  - 0° is fully deployed and 90° is packaged
  - Solar pitch angle < 20° and deployment angle < 20° deemed acceptable
    - ISS radiators were deployed with a ~20° angle between panels<sup>[6]</sup>

Investigation Values	
Panel Length	1 m
Panel Width	2 m
Panel Count	8
Radiation Temperature (eff)	400 K
IR Emissivity	0.85
Solar Absorptivity	0.3
Fin Effectiveness	0.85

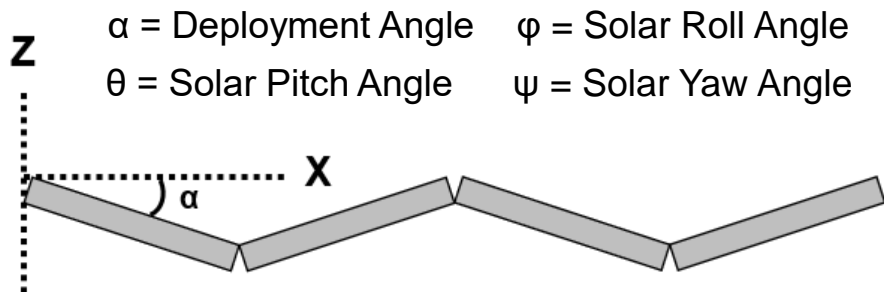
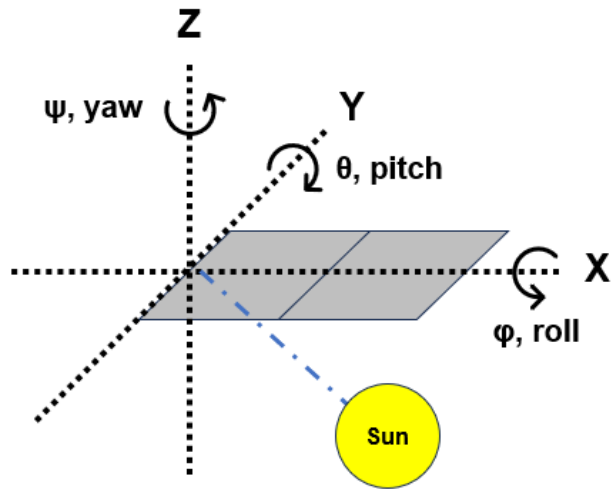

$\alpha$  = Deployment Angle     $\phi$  = Solar Roll Angle  
 $\theta$  = Solar Pitch Angle     $\psi$  = Solar Yaw Angle

**Bi-Wing Heat Rejection Capability**  
 (relative to theoretical max @  $T_{sink} = 0$  K)

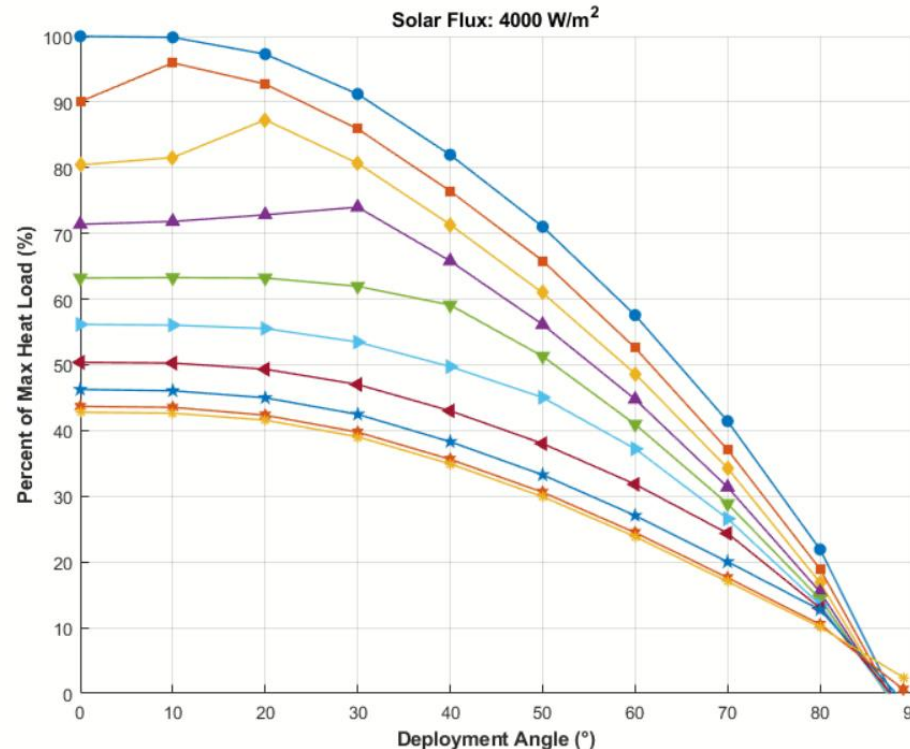

**Solar Pitch Angle**

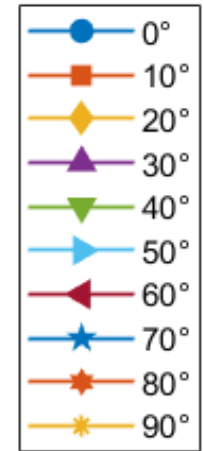



# Integrated Thermal Model Development

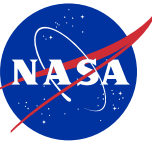

- Performing integrated radiator unit and fluid loop design trades with developed thermal models
  - Simulating thermal performance of the radiator and fluid loops across operational conditions, both online and offline reactor states, space thermal environments, freeze/thaw cycles, and thermal limit constraints
  - Building and refining models to investigate state properties, thermal resistances, and component selection/placement
  - Integration and definition of deployment mechanisms and in-space assembly interfaces is ongoing concurrently

## Initial Candidate Fluid Loop Concepts

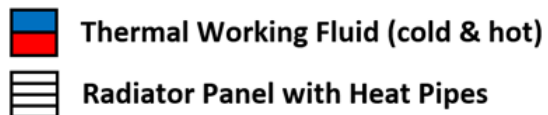

## Thermal Nodal Network Model<sup>[15]</sup>

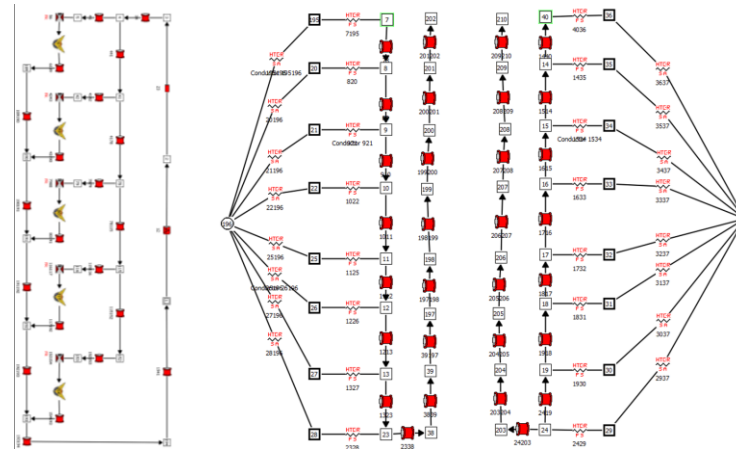

The Generalized Fluid System Simulation Program (GFSSP) is a general-purpose computer program for analyzing steady state and time-dependent flowrates, pressures, temperatures, and concentrations in a complex flow network

## Radiator Panel TD Model

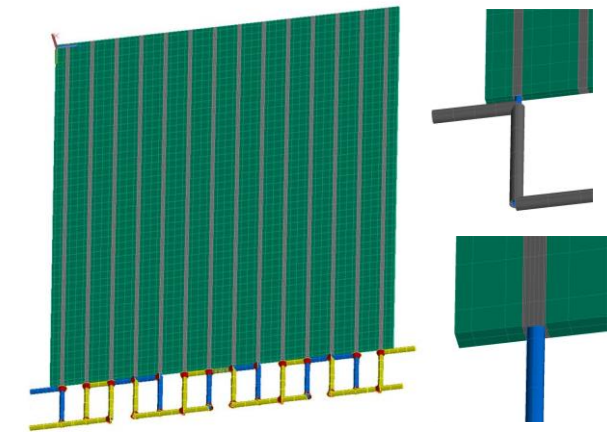

Developed based on models generated for the 2<sup>nd</sup> Generation Radiator Demonstration Unit (RDU) technology<sup>[16]</sup>



# Initial Radiator Unit Thermal Results



- Identified options for further analysis
  - Considerations include thermal performance (coupling between hot and cold lines), redundancy, total pipe length/mass, fluid pressure drop, compatibility with deployment mechanisms and/or in-space assembly interfaces, thermal contact resistances

Title / Element	Option 1	Option 2	Option 3	Option 4
Initial Layout Sketch				
TD Model (Based on 2nd Gen. Radiator Demo Unit)				

Red and Orange = HOT trunkline  
Blue and Green = COLD trunkline

**Note:** Hot Case Sink Temperature = 290 K, Cold Case Sink Temperature = 6.2 K



# Future Work



- **Define Baseline Radiator Unit Design**
  - Establish a baseline radiator unit with detailed specifications for thermal, mechanical, structural, and power/data interfaces, including potential hardware mockups for validation.
- **Model Environmental and Structural Survivability**
  - Develop comprehensive environmental and structural load models to assess radiator and fluid loop survivability under MMOD, launch, and in-space loading scenarios, including thruster-induced loads and commissioning operations. Ensure pressure vessel integrity with appropriate factors of safety.
- **Further Develop Integrated Thermal Models**
  - Simulate thermal performance of the radiator and fluid loops across operational conditions—both online and offline reactor states—considering various orientations relative to planetary bodies, freeze/thaw cycles, and mission thermal constraints.
- **Simulate Radiator Installation and Commissioning**
  - Analyze kinematics and dynamics of radiator deployment and in-space assembly, accounting for robotics placement, radiator package handling, and installation and commissioning sequences.
- **Define and Assess Fluid Interfaces**
  - Determine the form, fit, and function of fluid interfaces aligned with thermal loop requirements; identify components (e.g., seals), assess NaK material compatibility, and produce iterative mockups for functional testing.





# References



- [1] A. Martin, "SNP-PLAN-0043 Space Nuclear Propulsion (SNP) Technology Maturation Plan for High Power Nuclear Electric Propulsion - DRAFT," NASA Marshall Space Flight Center, Huntsville, 2023.
- [2] "Nuclear Electric Propulsion Technology Could Make Missions to Mars Faster - NASA," NASA, Jan. 10, 2025. <https://www.nasa.gov/centers-and-facilities/langley/nuclear-electric-propulsion-technology-could-make-missions-to-mars-faster/>
- [3] W. Machemer, M. Duchek, and D. Nikitaev, "Considerations for Radiator Design in Multi- Megawatt Nuclear Electric Propulsion Applications." Available: <https://ntrs.nasa.gov/api/citations/20220019167/>
- [4] M. E. Duchek, W. Machemer, C. Harnack, M. Clark, A. Pensado and K. Palomares, "Key Performance Parameters for MW-Class NEP Elements and Their Interfaces," AIAA ASCEND, Nevada, 2022.
- [5] Boeing, "Active Thermal Control System (ATCS) Overview"
- [6] J. A. Oren and H. R. Howell, "Space Station Heat Rejection Subsystem Radiator Assembly Design and Development," *SAE Transactions*, vol. 104, pp. 1086–1095, 1995, doi: <https://doi.org/10.2307/44612020>.
- [7] W. K. Alan, M. L. Fleming, and A. Y. Lee, "Design and Performance of Space Station Photovoltaic Radiators," *SAE Transactions*, vol. 102, pp. 1018–1026, 1993, doi: <https://doi.org/10.2307/44740054>.
- [8] B. Mattfeld, C. Stromgren, H. Shyface, D. Komar, W. Cirillo, and K. Goodliff, "Trades Between Opposition and Conjunction Class Trajectories for Early Human Missions to Mars," Available: <https://ntrs.nasa.gov/api/citations/20150001240/downloads/20150001240.pdf>
- [9] T. Valdés, A. Stark, W. Grier, "Thermal Considerations for 2039 Opposition Class Nuclear Electric Propulsion/Chemical Propulsion Crewed Mars Mission," NASA TFAWS 2025, August 4, 2025
- [10] A. Juhasz, "An Analysis and Procedure for Determining Space Environmental Sink Temperatures With Selected Computational Results," 2001. Available: <https://ntrs.nasa.gov/api/citations/20010014168/downloads/20010014168.pdf>
- [11] L. Carrillo, N. Jsc, D. Farner, J. Engineering, and C. Preston, "NASA-TFAWS Short Course ISS Payload Thermal Environments," 2015. Accessed: Jul. 01, 2025. [Online]. Available: <https://tfaws.nasa.gov/wp-content/uploads/TFAWS2015-SC-ISS-Payload-Thermal-Design.pdf>
- [12] L. Erickson, B. Barnes, C. Sladek, "Thermal Analysis for EVA Twilight Scenario on a Flat Plane," JETS-JE33-23-TLSS-DOC-00031, June 8, 2023.
- [13] R. Henson, G. Laubach, J. Iovine, G. Lucas, "A Routine (FLXCAL) to Determine EVA Cube Fluxes using SINDA Temperatures," June 20, 2003.
- [14] D. Pietro, "Radiator Sizing for Venus Flyby," May 29, 2022.
- [15] "Generalized Fluid System Simulation Program (GFSSP), Version 702 (Educational Version)(MFS-32929-1) | NASA Software Catalog," *Nasa.gov*, 2025. <https://software.nasa.gov/software/MFS-32929>
- [16] Ellis, David. "Summary of the Manufacture, Testing and Model Validation of a Full-Scale Radiator for Fission Surface Power Applications - NASA Technical Reports Server (NTRS)." NASA, NASA, [ntrs.nasa.gov/citations/20110012006](https://ntrs.nasa.gov/citations/20110012006).



---

# Backup



# Initial Sub-Functional Flow Diagram #1

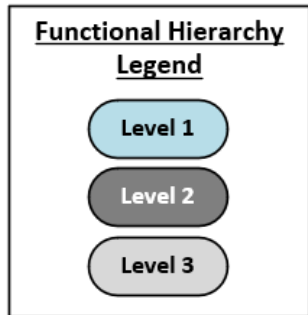
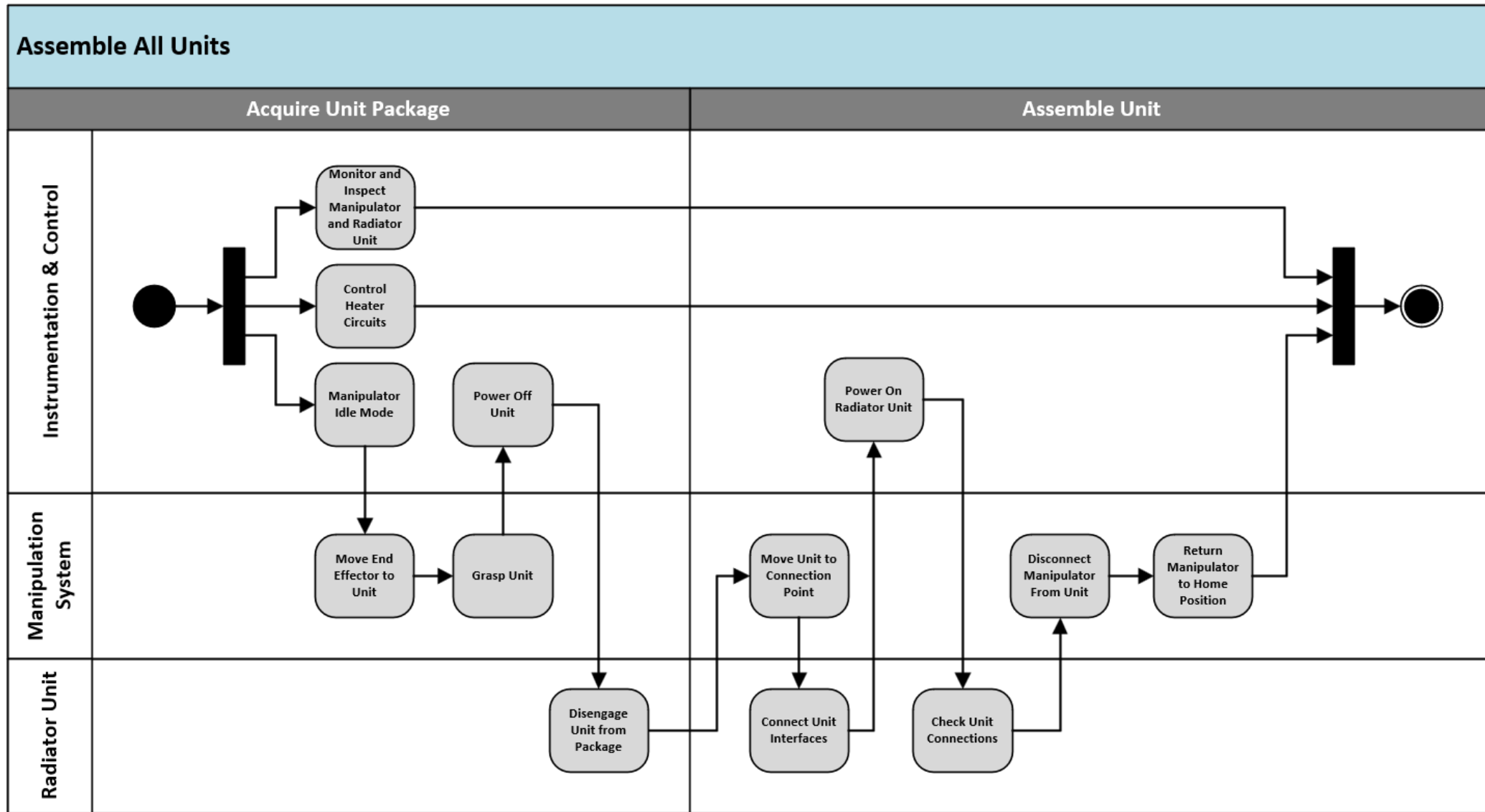



# Initial Sub-Functional Flow Diagram #2

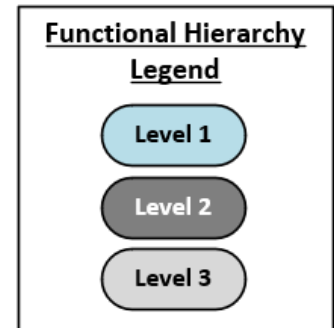
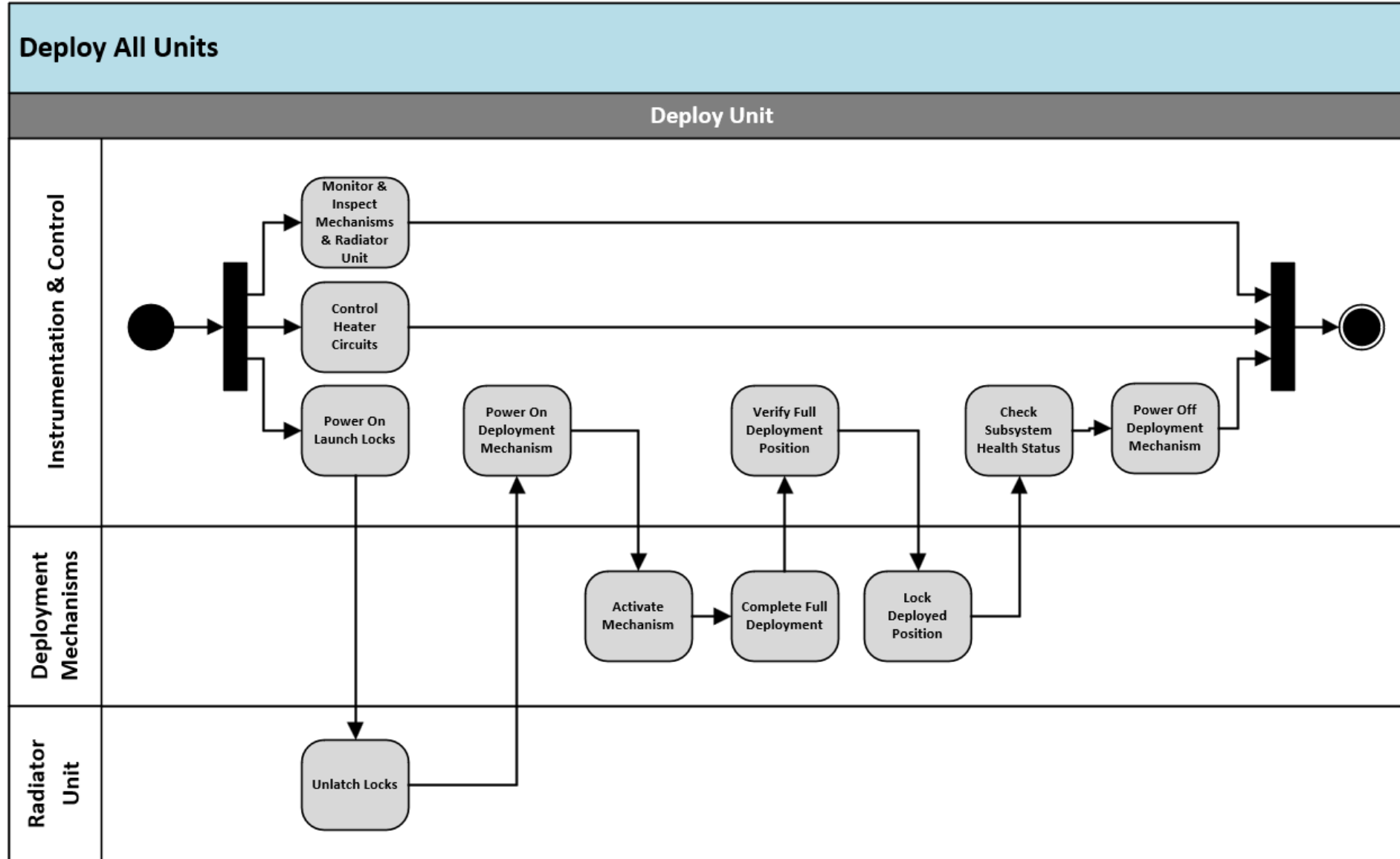



# Initial Sub-Functional Flow Diagram #3

