

NASA TECH BRIEF

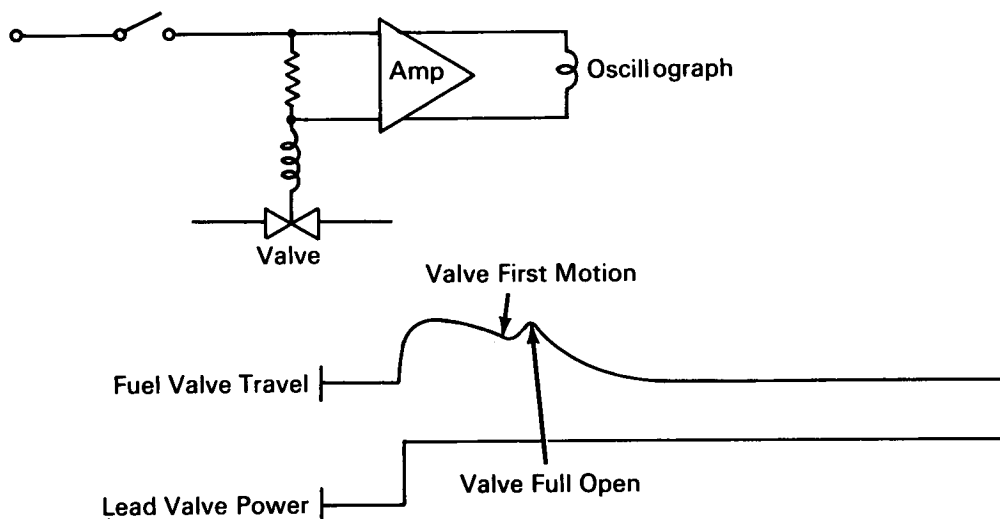

NASA Tech Briefs are issued to summarize specific innovations derived from the U.S. space program, to encourage their commercial application. Copies are available to the public at 15 cents each from the Clearinghouse for Federal Scientific and Technical Information, Springfield, Virginia 22151.

Monitoring Circuit Accurately Measures Movement of Solenoid Valve



The problem:

To accurately measure the valve travel of solenoid operated valves, which are generally hermetically sealed. Valve opening times can be established only by inference from the rate of change of the pressure levels in various portions of the fluid system in which they are employed. When such valves are used for metering or critical operational sequencing, inferred values of travel time are not sufficiently accurate for reliable control, due to the influence of system volume and pipe size on the rate of change of pressure.

The solution:

A solenoid operated valve in a control system powered by direct current. The valve travel can be reliably monitored through accurate measurement of the rate of change of the solenoid operating current. This current level is a direct function of the position of the solenoid armature in relation to the coil. Absolute values of current will be found to vary

over a wide range; however, the characteristic shape of the current vs time plot is found to be similar for practically all dc solenoids.

How it's done:

A small resistor with sufficient capacity to match the solenoid maximum current requirement is inserted in series with the solenoid coil. The voltage drop across this resistor is the input to a solid-state amplifier. The amplifier output drives a galvanometer in a recording oscillograph operating at approximately 10 inches/second. By recording several valves on the same oscillograph, both valve opening time and sequence of operations are critically measured.

Notes:

1. This system is currently in operation with a 28-vdc power system used for control of fluids in liquid rocket motor test facilities. In this application, the sequencing of various flows is critical to the ± 10 -millisecond level.

(continued overleaf)

2. Inquiries concerning this invention may be directed to:

Technology Utilization Officer
Marshall Space Flight Center
Huntsville, Alabama 35812
Reference: B66-10568

Patent status:

Inquiries about obtaining rights for the commercial use of this invention may be made to NASA, Code GP, Washington, D.C. 20546.

Source: J. D. Gillett
of North American Aviation Inc.,
under contract to
Marshall Space Flight Center
(M-FS-1829)