

# NASA TECH BRIEF

## Lewis Research Center



NASA Tech Briefs announce new technology derived from the U.S. space program. They are issued to encourage commercial application. Tech Briefs are available on a subscription basis from the National Technical Information Service, Springfield, Virginia 22151. Requests for individual copies or questions relating to the Tech Brief program may be directed to the Technology Utilization Office, NASA, Code KT, Washington, D.C. 20546.

### LOW COST UNIFORM HEAT SOURCE

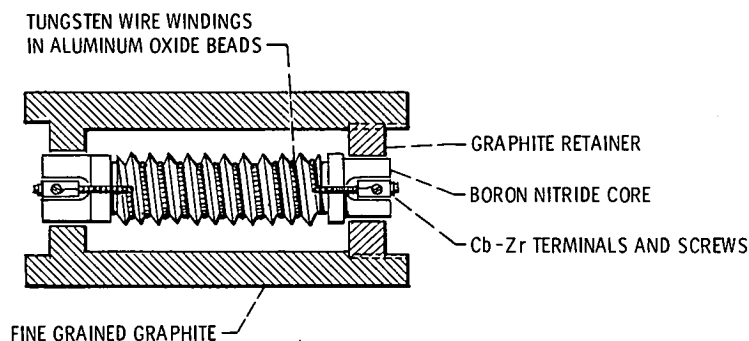

Figure 1. - Cross section of simulated isotope heat source.

#### The Problem:

A Brayton power system is being developed to provide up to 15 kilowatts of electric power for space applications. In space applications, the heat supply will be an isotope heat-source assembly which will radiate heat to the working gas contained in a heat exchanger. For ground test purposes, a simulated heat source was needed which was not radioactive and therefore would not require the precautionary practices involved in handling an isotope heat source.

Requirements were:

1. Power output of 400 watts with the heat-emitting surfaces at a temperature of approximately 1366 K (2000°F).
2. Heat-emitting surfaces of the same size, shape, and material as the isotope heat source; i.e., a hexahedron 17.15 cm (6.75 inches) high and 8.9 cm (3.5 inches) across the flats, made of graphite for high emissivity and uniform heat flux.
3. Sufficient operating life expectancy to conduct all preliminary testing of the Brayton power system; i.e., approximately 5000 hours.

Available commercial heat sources were too large and required large power supplies to meet these requirements.

#### The Solution:

An electrically-powered heat source designed and built from readily available materials which operates on ordinary 110 vac power.

#### How It's Done:

The heat source (Figure 1) consists of a tungsten filament heating element wound onto a spirally-grooved boron nitride core and inserted in the hollowed-out graphite hexahedron. The tungsten filament is designed to operate at a temperature of 1588 K (2400°F) with a power output of 400 watts. The filament is 0.51 mm (20 mils) in diameter and 213 cm (84 inches) in length. The boron nitride core is 4.45 cm (1.75 inches) in diameter and 15.24 cm (6 inches) in length. An oval-shaped stub on one end fits into a slot in the end of the graphite jacket to prevent the core from rotating. The opposite end of the core is round and fits into a recess in the retaining cap. Aluminum oxide beads threaded onto the tungsten filament prevent interaction between the filament and the core. The hollow interior of the graphite jacket is 6.35 cm (2.5 inches) in diameter.

(continued overleaf)

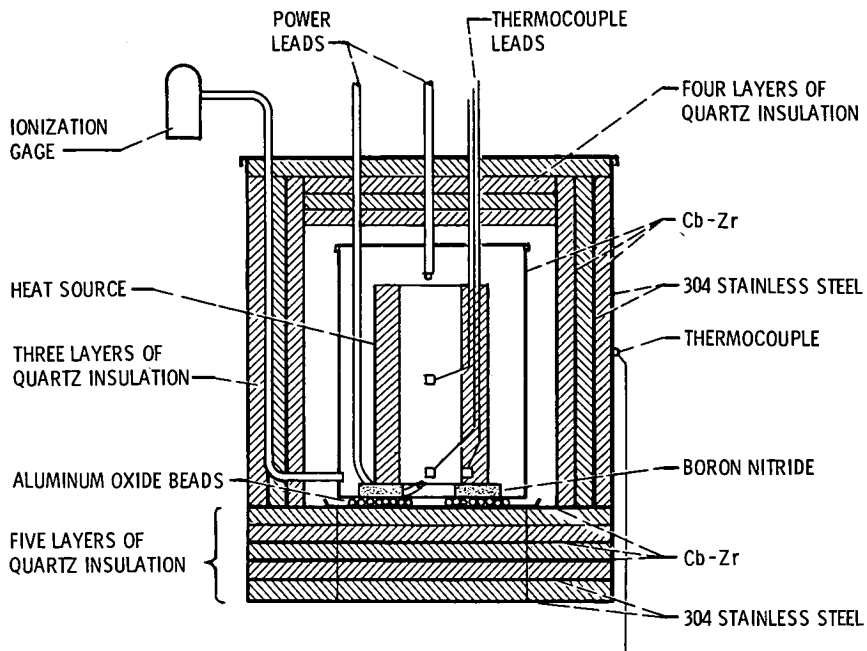

Figure 2. - Cross section of insulated container with heat source installed.

The heat source was tested in an insulated container (Figure 2) installed in a vacuum chamber. The insulated container was constructed of alternate layers of quartz felt insulation and thin metal sheets; the metal sheets closest to the heat source were columbium-zirconium alloy, the outer layers and outer container were 304 stainless steel. Instrumentation included thermocouples embedded in the center of the boron nitride heater core and in the surface of the graphite jacket, and current and voltage meters for the heater. Three surface thermocouples were used to measure the temperature uniformity of the radiating surface.

Thermocouple readings were taken on a two-channel recording milli-voltmeter. Pressures in the test chamber were measured with ionization gages.

**Notes:**

1. This heat source was successfully operated for over 5000 hours at rated power and temperature, and was successfully cycled six times. Material analysis showed no reaction problems between the materials due to the high temperature.
2. The heat source size, shape, and output were dictated by the particular application for which it was designed. The design principles employed are readily adaptable to the design of heat sources for other applications.
3. As an extension of this design, the graphite jacket can be impregnated for evacuation and sealed, thus making the heat source suitable for use outside of a vacuum environment; at temperatures lower than the oxidation temperature of the graphite.

4. The following documentation may be obtained from:  
National Technical Information Service  
Springfield, Virginia 22151  
Single document price \$3.00  
(or microfiche \$0.95)

Reference: NASA TM-X-2374 (N71-34621), Simulated Isotope Heat Source for Use in Brayton Power Systems

5. Technical questions may be directed to:  
Technology Utilization Officer  
Lewis Research Center  
21000 Brookpark Road  
Cleveland, Ohio 44135  
Reference: B73-10011

**Patent Status:**

Inquiries concerning rights for the commercial use of this invention should be addressed to:

NASA Patent Counsel  
Mail Stop 500-113  
Lewis Research Center  
21000 Brookpark Road  
Cleveland, Ohio 44135

Source: R.B. Smith and G.M. Prok  
Lewis Research Center  
(LEW-11903)