

# THE USE OF A SATELLITE COMMUNICATIONS SYSTEMS FOR COMMAND AND CONTROL OF THE NATIONAL AERONAUTICS AND SPACE ADMINISTRATION SURROGATE UNMANNED AERIAL SYSTEM RESEARCH AIRCRAFT

Charles T. Howell,\* Frank Jones,† Brian Hutchinson,‡ Claude Joyce,<sup>a</sup> Skip Nelson,<sup>o</sup> and Mike Melum<sup>a</sup>

The NASA Langley Research Center has transformed a Cirrus Design SR22 general aviation (GA) aircraft into an Unmanned Aerial Systems (UAS) Surrogate research aircraft which has served for several years as a platform for unmanned systems research and development. The aircraft is manned with a Safety Pilot and a Research Systems Operator (RSO) that allows for flight operations almost anywhere in the national airspace system (NAS) without the need for a Federal Aviation Administration (FAA) Certificate of Authorization (COA). The UAS Surrogate can be remotely controlled from a modular, transportable ground control station (GCS) like a true UAS. Ground control of the aircraft is accomplished by the use of data links that allow the two-way passage of the required data to control the aircraft and provide the GCS with situational awareness. The original UAS Surrogate data-link system was composed of redundant very high frequency (VHF) data radio modems with a maximum range of approximately 40 nautical miles. A new requirement was developed to extend this range beyond visual range (BVR). This new requirement led to the development of a satellite communications system that provided the means to command and control the UAS Surrogate at ranges beyond the limits of the VHF data links. The system makes use of the Globalstar low earth orbit (LEO) satellite communications system. This paper will provide details of the development, implementation, and flight testing of the satellite data communications system on the UAS Surrogate research aircraft.

## INTRODUCTION

The Cirrus Design SR22 aircraft is a small, single-engine, four-place, composite construction aircraft that NASA Langley acquired to support NASA flight research programs like the Small Aircraft Transportation System (SATS) Project. The aircraft has an empty weight of 2512 lbs, a gross weight of 3400 lbs, a load capacity of 988 lbs, and a fuel capacity of 81 gallons (486 lbs). The engine is a 310-hp Teledyne Continental model IO-550-N with 6 cylinders, fuel injection, and is normally aspirated. The SR22 aircraft has a wingspan of 33-ft, length of 26-ft, and a height of 8-ft. Performance specifications include a cruise speed of 180 knots, climb rate of 1400 ft/min,

---

\* Flight Test Integration Engineer, Research Services Directorate, NASA Langley Research Center.

† Associate Director, Research Services Directorate, NASA Langley Research Center, Hampton, VA.

‡ Software Engineer, Research Services Directorate, NASA Langley Research Center, Hampton, VA.

<sup>a</sup> Communications Engineer, Analytical Mechanics Associates, Inc., Hampton, VA.

<sup>o</sup> Chief Executive Officer, ADS-B Technologies Inc., Anchorage, AK.

<sup>a</sup> Chief Engineer, ADS-B Technologies Inc., Anchorage, Alaska, AK.

takeoff roll of 1100-ft, and a ceiling of 17,000 feet. Systems were installed to support flight test research and data gathering. These systems include separate research power, multi-function flat-panel displays, research computers, research air data and inertial state sensors, video recording; data acquisition, data link, S-band video and data telemetry, Automatic Dependent Surveillance-Broadcast (ADS-B), instrumented surfaces and controls, and a Research Systems Operator (RSO) workstation. The transformation of the SR22 to a UAS Surrogate was accomplished in phases. In the first phase, an existing autopilot was modified to accept external commands from an aircraft research computer that was also connected by redundant data link radios to the GCS. An electro-mechanical auto-throttle was added in the next phase to provide ground station control of airspeed. The next phase added satellite data communications to extend the range of operation. The last phase added waypoint navigation and the ability to uplink flight plans from the GCS. The UAS Surrogate has been used to test algorithms to “detect-sense-and-avoid” air traffic and other research projects. The NASA Langley Cirrus SR22X aircraft, N501NA, is shown in Figure 1 and the Research System architecture is shown in Figure 2.



**Figure 1. The Cirrus SR22 UAS Surrogate Research Aircraft.**

## **THE GLOBALSTAR SATELLITE COMMUNICATIONS SYSTEM**

The current Globalstar Low Earth Orbit (LEO) constellation of 32 satellites and more than twenty ground stations is not sufficient to provide uninterrupted continuous coverage but is quite sufficient to allow very meaningful testing of this surrogate UAS platform. With the deployment of at least another eight satellites and full implementation of the second generation 256 kbps equipment, Globalstar with ALAS could adequately meet the requirements for over the horizon command and control of a UAS and could also provide reliable, secure Air Traffic Control surveillance. The system of satellites and ground-based gateways operate like mirrors in the sky or “bent pipes”. A call from a phone or modem can be picked up by one or more satellites and connected to a ground

based gateway. On any given call, several satellites transmit a caller's signal via code division multiple access (CDMA) technology to a terrestrial satellite dish at the appropriate gateway. The system uses multiple frequencies to transmit signals. Phones and modems transmit signals to the Globalstar satellites on L-band signals and satellite to phones over S-band signals. Satellite to gateway ground stations communication is via C-band signals. The phone to multi-satellite call capability makes the system path diverse and provides greater assurance a call will get through even if one satellite loses the signal or the phones move out of view of one satellite<sup>§</sup>. The terrestrial gateways process the calls and connect them to the fixed or cellular phone networks and to the internet. The Globalstar Gateways contain most of the system key technologies that are accessible, easily maintained and upgradeable. The number and spacing of the ground stations are such that the signal latency is minimized to less than 200 ms one way and 300 ms end-to-end<sup>\*\*</sup>. An illustration of the Globalstar system is shown in Figure 3.

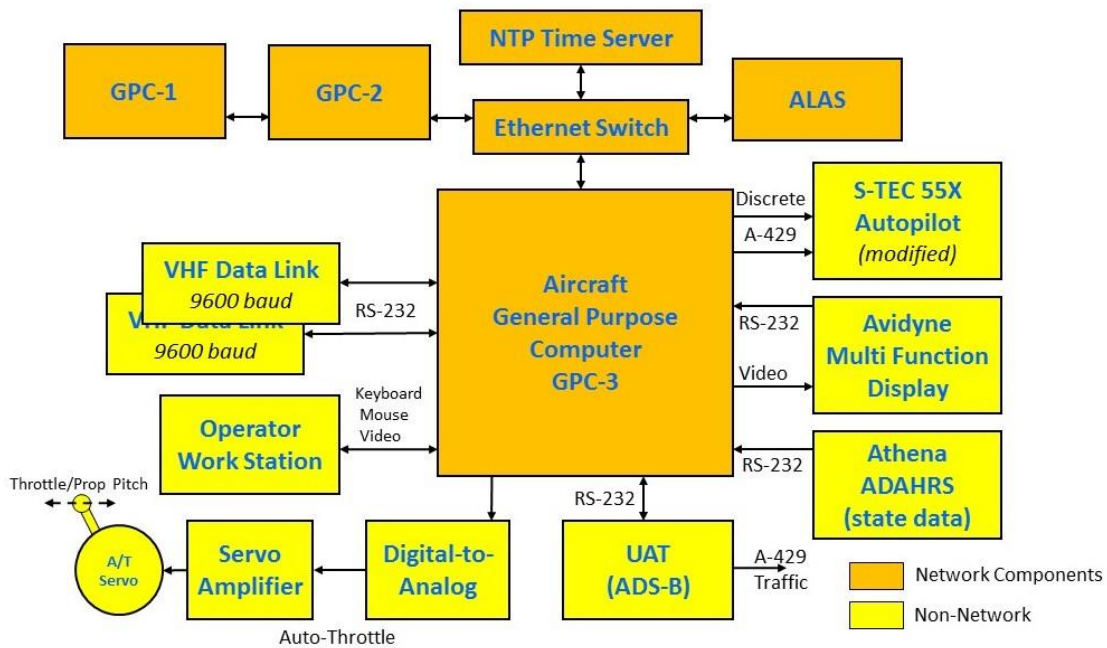

Figure 2. The UAS Surrogate Major Components.

### In-House Effort to build a Satellite Data Communications System

The redundant VHF data link radios turned out to be consistent and reliable at an operating range of 35 to 40 nautical miles or less from the GCS. A requirement developed to extend the operating range of the UAS Surrogate to beyond the limitations of the VHF data links. It was realized that satellite communications technology was the best way to accomplish this goal. Of the available satellite communications systems, only two systems offered small light weight data communication systems suitable for small general aviation aircraft like the UAS Surrogate. Globalstar

<sup>§</sup> Globalstar Constellation, retrieved March 23, 2017, from <http://www.globalstar.com/en/index.php?cid=8300>

<sup>\*\*</sup> What is Space-Based ADS-B? Retrieved March 28, 2017, from <http://www.ads-b.com/space-based.htm>

and Iridium are the two low earth orbit (LEO) systems with very different architectures. The Iridium system is composed of 66 satellites in six orbital planes with each satellite cross-linked to four others and two primary gateway ground station. The Iridium satellite's near polar orbits and cross-link capability allows for 100% coverage of the earth's surface. The satellite cross-links allow Iridium phone to phone calls without passing through the gateway ground station. The Iridium system is primarily a voice system but does provide data communications at the rate of 24.4 kbps with 128 kbps possible by 2019<sup>††</sup>. In contrast, the Globalstar system is a pure "bent pipe" system that requires each call to go through a satellite and a gateway before being routed to its destination. The Globalstar system requires the user to be within a thousand miles of a gateway ground station and does not provide 100% earth coverage or high latitude coverage. The Globalstar system is also primarily a voice system but also provides for data communications at 9600 bps with 256 kbps expected by summer 2017. The Iridium system has worldwide coverage but the satellite cross-links make signal latency variable with round-trip averages of 1800 ms or more depending on the path taken<sup>‡‡</sup>. Although the Globalstar system does not provide worldwide coverage, it does have a fixed or not to exceed latency value and a higher data rate than Iridium.

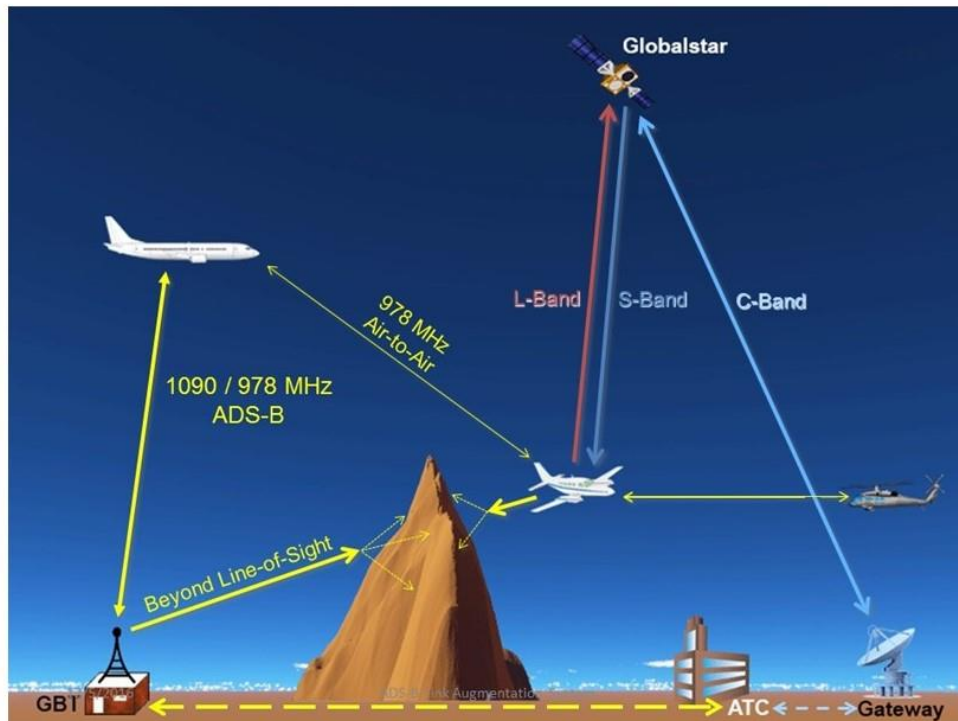

**Figure 3. The Globalstar Satellite Communications System.**

In 2011, the decision was made to build a satellite data communications system from commercially available Globalstar components to extend the range of the UAS Surrogate. It was decided

<sup>††</sup> Iridium Voice and Data Calls Retrieved March 26, 2017, from [https://en.wikipedia.org/wiki/iridium\\_Communications](https://en.wikipedia.org/wiki/iridium_Communications)

<sup>‡‡</sup> Iridium Voice and Data Calls, Retrieved March 26, 2017, from [https://en.wikipedia.org/wiki/iridium\\_Communications](https://en.wikipedia.org/wiki/iridium_Communications)

that the higher data throughput and the low latency characteristics of the Globalstar system made it the best system choice. Several Globalstar GSP-1720 modems were purchased for the in-house effort to build the system. The GSP-1720 is small, lightweight, low power, and capable of full-duplex voice and data calls. Several GSP-1700 handsets, two GSP-2900 phones, and accessories were also purchased for use in the development effort. Early efforts to manually make voice and data calls using the various Globalstar equipment was successful after solving a few technical issues with the proper operation of the different equipment. Data and voice calls were made to and from the GSP-1720 modems and the GSP-2900 fixed phones and voice calls were made between all phones.

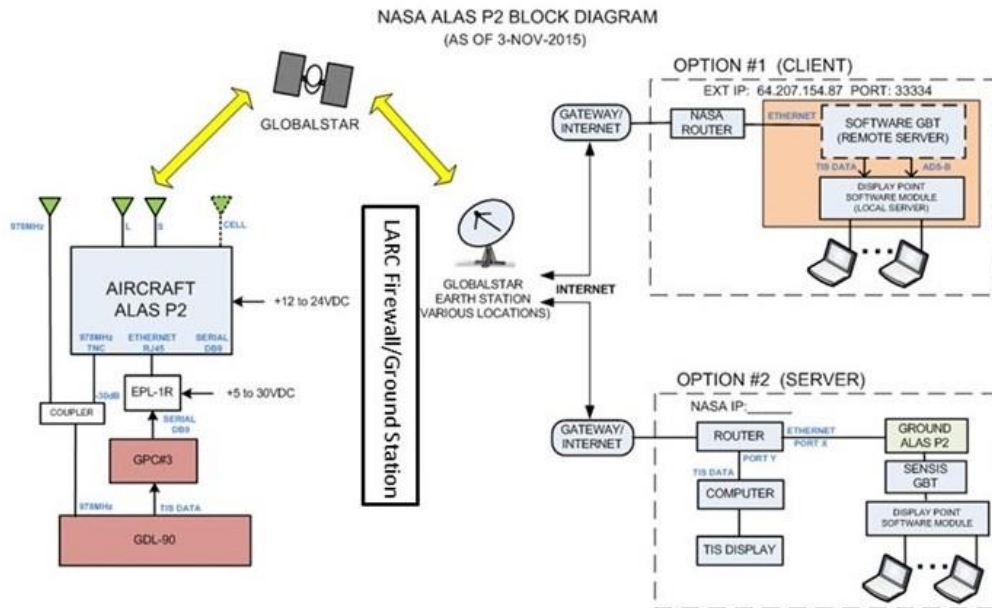

**Figure 4. The ADS-B Link Augmentation System.**

Several technical difficulties were encountered with the Globalstar equipment in several areas. Automating data calls through software control revealed several issues primarily with the GSP-1720 modems. Differences were discovered with the observed operation of the GSP-1720 modems versus the characteristics described in the documentation. The GSP-1720 technical documentation was originally written in 2007 and was never updated to correct several technical errors. The lack of accurate technical data complicated the task of writing software. These and other technical difficulties were never fully resolved. Technical support was a problem partly due to the loss of technical personnel in the Globalstar bankruptcy of 2002 and later restructuring<sup>§§</sup>. Other technical difficulties encountered during the development effort included difficulties interfacing Globalstar equipment to aircraft equipment such as aviation grade antennas and aircraft intercommunications equipment. In spite of these difficulties, some success was established with the passing of command and control data between the UAS Surrogate aircraft and the GCS while on the ground. However, the communications link between the GCS and aircraft was never made to be long lasting, reliable or robust.

### Partnership with ADS-B Technologies

<sup>§§</sup> Globalstar corporate structure and financing, Retrieved March 26, 2017, from <https://en.wikipedia.org/wiki/Globalstar>

Research efforts to find the successful use of the Globalstar system to communicate data between air and ground led to the work of ADS-B Technologies Inc. of Anchorage, Alaska. It was discovered that ADS-B Technologies pioneered the use of the Globalstar satellite system to pass automatic dependent surveillance – broadcast (ADS-B) and other data from aircraft to the ground. Traditionally, ADS-B data is transmitted from aircraft to aircraft as well as to and from ground-based facilities. Due to the mountains and valleys in Alaska, traditional ADS-B signal transmission is less reliable. Passing the ADS-B signals via satellite solves the problem of signal blockage due to harsh terrain including mountains and valleys.

Satellite-based ADS-B also solves the problem of the open and unsecured nature of ADS-B signals in general. The ADS-B system was never designed to be secure or include any form of encryption. Consequently, the open and unsecured nature of ADS-B signals is a serious concern to many potential ADS-B users. Anyone with an inexpensive, easy to build ADS-B receiver can identify and track ADS-B equipped aircraft which includes airliners, private, and business aircraft. The ADS-B Link Augmentation System (ALAS) was invented and developed by ADS-B Technologies to solve both of these problems. The ALAS was designed to pass ADS-B data via the Globalstar system but is also capable of passing other digital data including Ethernet-based internet protocol (IP) data.

The ALAS was designed for aircraft use and ADS-B Technologies has demonstrated its use in many successful flight tests in Alaska as well as long-distance flights across the US. Globalstar and ADS-B Technologies have formed a partnership to help develop aviation related technologies which are outside the Globalstar normal product line. As a result of this partnership, ADS-B Technologies has access to the technical knowledge needed to develop ALAS and other products. The decision was made to investigate the possibility of adapting ALAS to perform the data-link function for the UAS Surrogate. After consultations between NASA and ADS-B Technologies, a contract was put in place for the lease of two ALAS units and for engineering and technical services. The goal of the contract was to adapt ALAS to pass the command and control data between the UAS Surrogate and the GCS in order to operate beyond the range of the VHF data link system.



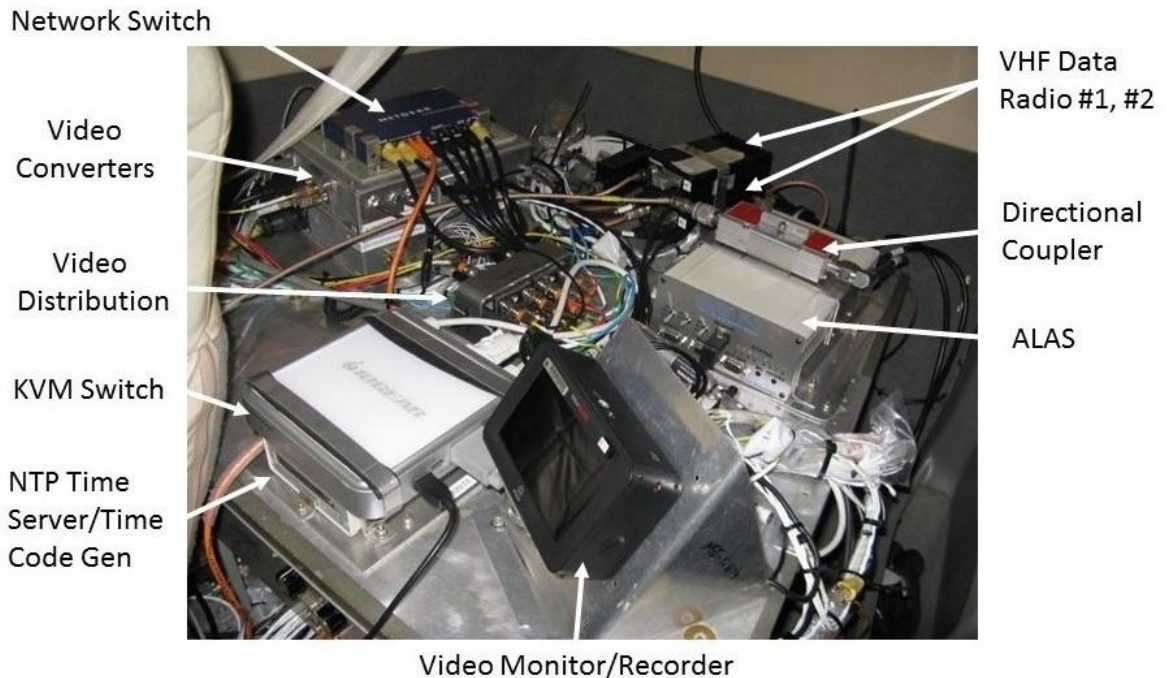

**Figure 5. The UAS Surrogate Components.**

### **The ADS-B Link Augmentation System (ALAS)**

The ALAS system is primarily designed to transmit own ship ADS-B data but the system is also capable of passing virtually any digital data that will pass within the Globalstar data channel bandwidth of 9600 bps. The ALAS is designed to sample own ship ADS-B transmissions through the use of a directional coupler that must be installed between the ADS-B transmitter and antenna. A sample of the ADS-B signal that is -30db below the maximum transmitter signal is fed via the coupler to the ALAS unit each second. The sampled data is decoded and stored for transmission. The ALAS system is designed to work with both Universal Access Transceiver (UAT) and Mode-S 1090 extended squitter (ES) ADS-B signals. The sampled own ship ADS-B signal is transmitted by Globalstar satellite to a gateway ground station and via the internet to a dedicated server operated by ADS-B Technologies.

The ALAS server processes and separates the ADS-B signals from any other transmitted data. The server is connected to a Ground-Based Transceiver (GBT) which decodes the transmitted ADS-B signals. The GBT is a dedicated piece of equipment designed to decode ADS-B signals and is a normal part of the ADS-B ground based infrastructure. The GBT decoded data is provided to the end user via a secure connection and dedicated server port. The non-ADS-B data is separated and sent to the end user via a separate server port. The ALAS block diagram is shown in Figure 4.

The primary external connection to the ALAS is via a wired Ethernet connection with a dedicated internal IP address. The ALAS has an internal processor running applications software which communicates with external connections, the Globalstar satellites, and the ground based server. The ALAS also contains a cellular modem which allows the system to connect to the server when Globalstar satellites are not available such as when the system is inside a hangar or building. An

ALAS front panel switch allows the user to select the communications method; satellite, cellular modem or both. The ALAS unit has light emitting diodes (LED) to indicate to the user the status of the unit and the availability of different signals. The ALAS unit requires the presence of GPS and ADS-B transmitter signals in order to properly operate and the unit has LED's to indicate signal validity. A LED also indicates the presence of a valid Globalstar satellite connection. With valid inputs, the ALAS unit will search for Globalstar satellites or cellular networks and make the appropriate connection to the server. The ALAS aircraft equipment installation is shown in Figure 5.

### **ALAS Aircraft Integration**

The UAS Surrogate aircraft has a network of three general purpose computers (GPC-1, GPC-2, GPC-3) with one primary computer (GPC-3) that connects to the various hardware interfaces and runs the applications software. Interface cards in GPC-3 allow it to interface to several RS-232 serial, ARINC 429, universal serial bus (USB) and analog discrete devices. The two additional computers are used to add compute power, run algorithms, and provide software partitioning. The data gathered by the main computer or any of the others can be shared over the network. The GPC-3 connections include the air data and heading reference system (ADAHRS), autopilot, auto-throttle, multi-function display (MFD), Operator Workstation, ADS-B system, dual VHF data link radios, and ALAS (Figure 2). The aircraft ALAS installation includes a Globalstar transmit/receive antenna, GPS antenna connection, directional coupler, 12 VDC power, and network switch connection. The Rockwell-Collins GS111m ADAHRS unit provides air data, attitude, position, rates, acceleration, and position data to GPC-3. The S-TEC 55X autopilot was modified in-house to allow GPC-3 to control all modes, provide steering signal inputs, and provide vertical speed control. The auto-throttle is an in-house design to control air speed using a servo motor connected to the throttle/prop pitch handle. The MFD is an Avidyne EX5000 unit modified by the manufacturer to allow switch selectable display of standard moving map displays or custom video output from the GPC-3 computer. The Research Systems Operator (RSO) sits in the back right seat and uses a 10.4" computer monitor mounted on the back of the front right seat along with a keyboard and mouse to control the computers and software. A Garmin GDL 90 Universal Access Transceiver (UAT) provides ADS-B data to the basic avionics as well as the research system. Two Teledesign Systems Inc. TS4000 VHF Radio Modems are used to transmit aircraft state and ADS-B data to the ground and receive command data from the GCS. The ALAS system was added to provide the beyond visual range (BVR) capability and redundancy to the radio modems. Aircraft centric ADS-B data was recently added to the radio modem data set and ALAS downlink data set to allow the GCS moving map display to show the traffic as seen by the aircraft. Aircraft ALAS and other antennas are shown in Figure 6.





**Figure 6. The UAS Surrogate Antennas.**

The ALAS interface software runs in GPC-3 and the two units are connected by a Netgear GS108 Gigabit Ethernet switch. The applications software “GAMAIN” reads the hardware configuration from an initial configuration (IC) file. The IC file is a text file which can be edited to specify which serial input/output ports and baud rates are used for the VHF radio modems, ADAHRS, MFD controls, and ADS-B system. The file also contains the relevant software executables to call, internet protocol (IP) addresses, ports and other variables which may change periodically. When the software executes, the IC file is read and the hardware and software environment is configured as required. The ALAS has a specific IP and port address and the aircraft software initiates communication with the IP and port address of the ground based server via ALAS. The ALAS will establish communications with the ground server via Globalstar or cellular system depending on the ALAS switch configuration. The GCS software separately establishes communication with the ALAS server via the ground-based internet. Once the aircraft GPC-3/ALAS and GCS are connected to the ALAS server, the two computers can exchange the required command, control, status and ADS-B data. If the aircraft or GCS software detects that the communications link with the server is broken, it will automatically try to re-establish the link.

### **Flight Tests**

An extensive set of ground tests, software development, and aircraft installations were performed before the ALAS was ready for flight testing. An earlier flight test of ALAS connectivity had revealed deficiencies in the original Globalstar compatible aircraft antenna and the ALAS coaxial cable connections to the antenna. As a result, a different improved model Antcom 5G1625LL-PA-XTT-1 antenna and low loss Andrew FSJ1-50B HELIAX® coaxial cables were procured and installed in the aircraft. The new antenna and cables produced significant improvements in ALAS

connectivity and reliability during ground tests and made the system ready for flight testing. A set of flight test cards were developed for ALAS using the same concept of operations (CONOPS) previously established for the UAS Surrogate. The basic CONOPS specifies that when the GCS is in control of the UAS Surrogate aircraft, any commands sent from the GCS are to be coordinated with the Safety Pilot over the VHF voice communications radio. An exception to this rule was for pre-briefed and pre-planned maneuvers. The ALAS flight test cards included exercising all of the standard UAS Surrogate commands which include altitude, heading, vertical speed and airspeed commands.

On August 31, 2016, the first attempt to perform command and control of the UAS Surrogate via the ALAS was made. The ALAS procedure involved verifying valid Globalstar satellite availability, GPS signals, and ADS-B signals by observing the LEDs on the unit. The applications software was run after verifying all required ALAS signals were valid. Except for the modified STEC autopilot and the autothrottle, all other research systems can be operating and verified on the ground before the flight. Established safety procedures require the aircraft to be flying at a minimum of 500 feet above ground level (AGL) before engaging the modified autopilot or autothrottle. After completing the ground checks and receiving air traffic control (ATC) clearance, the aircraft took off from Langley at 7:25 am. Soon after takeoff, a non-ALAS problem was discovered that prevented control of the aircraft via the modified S-TEC autopilot. This situation presented an opportunity to simply test the aircraft to GCS connectivity via ALAS without coupling to the autopilot by monitoring the flow of data to and from the aircraft and GCS. When connected to the GCS via ALAS or the VHF data radios, the aircraft software sends aircraft state and status messages at a rate of 3-Hz to the GCS to generate the moving map and status displays. Messages from the GCS are only sent to the aircraft when the GCS operator generates and sends one of the standard commands. Status displays, counters for messages transmitted and messages received in the aircraft and the GCS allow for real-time monitoring of ALAS connectivity. The flight test called for testing the robustness of the ALAS connection with extreme roll maneuvers. A series of right and left 45-degree bank angle turn maneuvers were executed by the pilot while the ALAS connection was monitored by the RSO and the GCS Operators. The ALAS maintained connection and data flow was normal for these maneuvers. The next test called for right and left 60-degree bank angle turns. The ALAS did lose connection during these extreme maneuvers. Once the connection was lost, the aircraft was returned to level flight and the ALAS connection was automatically re-established within about 10 seconds. This concluded the test flight and the aircraft returned to Langley.

The next opportunity to flight test ALAS occurred on September 14, 2016. Normal preflight procedures were followed and the aircraft took off from runway 26 at 2:26 pm. After takeoff, the aircraft climbed and headed west toward the normal flight test area located across the James River between Smithfield and Franklin, Virginia. The flight test called for repeating the extreme bank angle turn maneuvers to again test the robustness of the ALAS connection. A series of right and left 45-degree bank angle turn maneuvers were executed by the pilot while the ALAS connection was monitored by the RSO and the GCS Operators. The ALAS maintained connection and data flow was normal for these maneuvers. The next test called for the repeat of the right and left 60-degree bank angle turns. As before, the ALAS did lose connection during the left 60-degree bank angle turn but remained connected through the right turn. The UAS Surrogate maneuvers conducted through the modified STEC autopilot are limited by the internal control laws to standard rate two minute turns regardless of input commands. These limitations are part of the FAA certified autopilot design. The bank angle limit is generally between 15 to 20 degrees and is a function of the aircraft ground speed and other factors. Therefore, the 45-degree of bank capability of the ALAS connection is far greater than the autopilot will allow. Another planned ALAS test was the range test. This involved flying beyond the 40 nautical mile range of the VHF data link while monitoring

the ALAS connection on the aircraft and at the GCS. This test was also successful with the aircraft flying almost 50 nautical miles from Langley. Command and control via ALAS were the next planned test. With the aircraft stable at an altitude of 6,000 feet, the UAS Surrogate mode was enabled and the aircraft was under remote control at 3:00 pm. When first engaged, the UAS Surrogate systems are designed to sense the altitude, airspeed, and heading and maintain those values until commands are issued from the RSO or the GCS. The RSO enabled GCS control and the first set of commands were issued using the ALAS instead of the VHF data system. After verifying proper operation of remote command and control via the ALAS, the remote controls were used to fly the aircraft back toward Langley. After several minutes, the pilot decoupled the autopilot to manually fly the aircraft while the RSO and GCS operator continued to monitor the ALAS connection and data flow for the remainder of the flight which concluded at 3:22 pm. The flight test was considered to be very successful and verified the use of ALAS for command and control of the UAS Surrogate aircraft. The ALAS was used to support several other subsequent UAS Surrogate flight tests.

### **The future**

The ALAS was designed to use the 9600 bps channel bandwidth of the original Globalstar GSP-1720 modem. The second generation set of Globalstar satellites were designed for up to 256 kbps channel bandwidth. However, the ground infrastructure was limited to 9600 bps. Globalstar has started an upgrade of the ground infrastructure to accommodate the full satellite channel bandwidth and developed a higher bandwidth modem<sup>\*\*\*</sup>. As a result, ADS-B Technologies is developing an upgraded ALAS capable of the higher bandwidth. Current plans are to utilize the upgraded ALAS in the UAS Surrogate when it becomes available. The higher bandwidth and data throughput of the upgraded ALAS will enable other uses for the system and on other NASA research aircraft. One planned use of the additional bandwidth is to add voice over IP (VOIP) capability. This will provide the ability to link the aircraft inter-communications system with ground-based internet connected communications systems. This capability will allow the aircraft and crew to communicate with anyone on the ground that is connected to the same network, anywhere in the world.

### **CONCLUSION**

The goal of operating the UAS Surrogate aircraft beyond visual range of the GCS was realized with the use of ALAS and the Globalstar satellite communications system. Several successful flight tests were conducted to validate the system. The ALAS was used simultaneously with the VHF data radios to provide redundancy for short range operations less than 40 nm or alone for greater ranges. The 9600 bps bandwidth of the system proved to be adequate for the UAS Surrogate data-link requirements. The prospect of the enhanced ALAS with a bandwidth of 256 kbps will allow new capabilities for the UAS Surrogate to transfer additional data and at higher update rates.

### **References**

Globalstar. (2017, March 23). *Globalstar*. Retrieved from Globalstar.com: <http://www.globalstar.com/en/index.php?cid=8500>

---

<sup>\*\*\*</sup> Globalstar 2015 Annual Report, April, 2015, Retrieved from <http://www.globalstar.com/en/index.php?cid=6100>